

RESOLUTION 2023-100

A RESOLUTION OF THE MAYOR AND CITY COUNCIL OF THE CITY OF SIERRA VISTA, COCHISE COUNTY, ARIZONA; DECLARING A 30-DAY PUBLIC RECORD PERIOD FOR THE PROPOSED SIERRA VISTA MODIFIED MARICOPA COUNTY ROADWAY DESIGN MANUAL AND ASSOCIATED CODE AMENDMENTS TO CHAPTER 151 OF THE CITY CODE OF ORDINANCES, THE DEVELOPMENT CODE, AS SHOWN IN EXHIBITS A AND B, ATTACHED HERETO; AND AUTHORIZING AND DIRECTING THE CITY MANAGER, CITY CLERK, CITY ATTORNEY, OR THEIR DULY AUTHORIZED OFFICES AND AGENTS TO CARRY OUT THE PURPOSES AND INTENT OF THIS RESOLUTION;

WHEREAS, the City of Sierra Vista developed a Roadway Design Manual as modified from Maricopa County;

WHEREAS, the Roadway Design Manual includes construction standards for curb, gutter, sidewalk, access management, revised road classifications, revised street profiles, drive-thru storage, and landscaping and irrigation standards in the right-of-way;

WHEREAS, the Roadway Design Manual will consolidate codes and standards, be consistent with state and national traffic and construction standards, provide design flexibility, and be more user friendly for developers and contractors;

WHEREAS, associated Development Code Articles and Sections are required to be amended with the approval of the Roadway Design Manual;

WHEREAS, in accordance with the provisions of Article 151.31 of the Development Code and established policy, the City of Sierra Vista, has proposed amendments to the following: Section 151.04.008 (Clear Vision Area); Section 151.08.002 (General Regulations); Section 151.08.003 (Street Improvements Criteria); Section 151.08.004 (Street Design Standards); Section 151.08.005 (Street Access Standards), Article 151.17 (Access Standards), and Article 151.19 (Subdivision Regulations).

WHEREAS, City policy and Article 151.31 of the Development Code requires that the City Council review and decide on technical planning documents and text amendments; and

WHEREAS, per City policy and Article 151.31, the Planning & Zoning Commission recommended approval of the Roadway Design Manual and amendments to City Council; and

WHEREAS, under the provisions of Section 9-802 of the Arizona Revised Statutes, the proposed amendments to the City's Development Code shall be declared a matter of public record for a period of 30 days prior to being passed and adopted by ordinance.

NOW, THEREFORE, BE IT RESOLVED BY THE MAYOR AND CITY COUNCIL OF THE CITY OF SIERRA VISTA, COCHISE COUNTY, ARIZONA, AS FOLLOWS:

SECTION 1

The policy of the City of Sierra Vista declaring the Sierra Vista Modified Maricopa County Roadway Design Manual and associated text amendments to the Development Code as a public record be, and hereby is, reaffirmed.

SECTION 2

That certain documents entitled Exhibit A, Sierra Vista Modified Maricopa County Roadway Design Manual and Exhibit B, proposed amendments to Development Code, attached hereto, copies of which are on file in the office of the City Clerk, is hereby declared a 30-day public record.

SECTION 3

That the City Manager, City Clerk, City Attorney, or their duly authorized officers and agents are hereby authorized and directed to take all steps necessary to carry out the purposes and intent of this resolution.

PASSED AND ADOPTED BY THE MAYOR AND CITY COUNCIL OF THE CITY OF SIERRA VISTA, ARIZONA, THIS 14th DAY OF DECEMBER 2023.

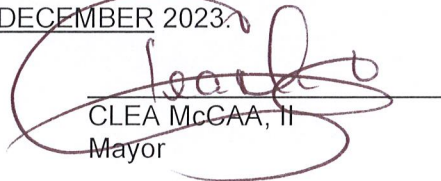
CLEA McCAA, II
Mayor

APPROVED AS TO FORM:

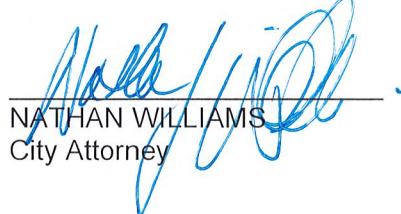
NATHAN WILLIAMS
City Attorney

ATTEST:

JILL ADAMS
City Clerk

PREPARED BY:

Jeff Pregler, AICP
Senior Planner

Chapter 1 Introduction

1.1. PURPOSE

The purpose of this manual is to standardize roadway design elements where necessary for consistency and to ensure, as far as is practical, that minimum requirements are met for safety, welfare, convenience, pleasant appearance, environmental sensitivity and economical maintenance.

The standards outlined in this manual cannot apply to all situations. They are intended to assist the professional engineer's competent work but not to substitute for it. Professional engineers are expected to bring the best of their skills and abilities to each project so that it is designed accurately.

Further, these standards are not intended to unreasonably limit any innovative or creative effort that might result in higher quality or increased cost savings for the public. Any proposed departure from these standards will be judged on the basis of whether such a variance will yield a compensating or comparable result that is fully adequate for road users and City residents.

The future traffic characteristics (vehicle types and volumes), roadway functional classification, and topography of the area are the basic criteria used to determine the design standards to be used. The roadway functional classification is to be used to determine the right of way requirements.

Any deviations from these published standards must be approved by the City Engineer or an authorized representative before the project design will be considered for approval. All design elements which do not meet these design standards require an approved design exception.

Design exception requests:

- Shall be submitted as a report Signed & Sealed by an Arizona Registered Professional Engineer.
- The design exception request shall:
 - Identify the standard for which a design exception is being requested and explain why the design exception is being requested.
 - Provide a minimum of two design exhibits: one design exhibit shall represent the best design that is fully compliant with existing standards. The second design exhibit shall incorporate the proposed design exception. Additional design exhibits may be required to evaluate other alternatives as requested by The City. All design exhibits shall show all existing conditions. All documentation that may be needed to evaluate the design exception shall be included in the design exception request (e.g., design exhibits, plan views, profiles, details, photos, calculations, location, type of terrain, road classification, current and future traffic volumes, design vehicle, etc.).

- Evaluate the effects of the design exception on the safety, operation, and maintenance of the facility. Identify how the design exception will impact (increase or decrease) City liability. Identify design features that are included to mitigate the effect of changing the design standard. Identify how the design exception will affect other standards. Include all supporting data: references, diagrams, design sketches, studies, and agency endorsements that support the design exception.

For privately initiated projects, design exception requests shall be submitted to the Community Development Department for review.

A letter of decision for the design exception request will normally be provided within a four-week time period. Due to federal review requirements the four-week time period does not pertain to design exceptions for federal aid projects or National Highway System (NHS) roads.

Developers and their engineering consultants, project designers, and others interested in preparing a design exception request are encouraged to discuss their potential design exception requests with City staff prior to initiating the analysis and documentation effort. This is to enable discussion and determination of the technical and alternatives analysis and associated documentation requirements, and to open communications between City staff and the developer or consultant. Such communication will help to ensure the proposed design will be in the community's best interests.

1.2 APPLICABILITY

These standards shall govern all construction and reconstruction of transportation facilities in City right-of-way. They shall also apply to all transportation facilities proposed to be built in right-of-way that is intended to be dedicated to the City of Sierra Vista and accepted into the City Road System for maintenance, unless written approval is otherwise obtained from the City of Sierra Vista

Before the City accepts a road for maintenance, it shall meet the standards outlined in this manual. Permitted work shall also conform to the requirements of the current City Resolutions or Ordinances governing permitted work. If noncompliant conditions are found after plan approval, improvements shall be made as necessary to bring the transportation facilities up to these standards prior to acceptance for maintenance. These standards shall be used by private parties, consulting engineers, public utilities, agencies, and City staff.

The standards apply to urban roadways except for freeways and freeway-type improvements. In these latter cases, the current applicable standards of the Arizona Department of Transportation shall apply.

For the purpose of this manual, the following definitions for maintenance/rehabilitation, roadway betterment, and construction/reconstruction shall be used:

Roadway maintenance/rehabilitation is defined as any work that does not change the geometric prism of the road. Such work will include any surface treatment of the same kind of surface (i.e. addition of gravel to gravel/dirt roads; crack sealing, chip sealing; slurry seal; micro-surfacing; surface recycling, cold mix or hot mix recycling, road mixes or overlays less than or equal to 2½ inches to paved roads; and incidental drainage improvements).

Roadway betterment is defined as a low-cost investment in transportation improvements, typically maintenance activities or safety improvements projects that may include pavement widening, resurfacing, grading, guardrail, or bridge repair activities that raise the traffic service level of a road or improves its safety or operating efficiency. Betterment projects costing less than \$300,000 may be funded out of the maintenance/rehabilitation budgets. The objective is to preserve and maintain City roads in a fiscally conservative manner.

Roadway construction and reconstruction is defined as any work that changes the geometric prism or surface type of the roadway. Such work will include roadway widening, penetration and chip seal on existing gravel/dirt surfaces, overlays greater than 2½ inches, and major drainage improvements.

Chapter 2 Transportation Planning and Studies

2.0 FUNCTIONAL CLASSIFICATION

Functional classification is the process by which roadways are grouped into classes or systems according to the service they provide. The basic functional systems used are parkways, arterials, collectors, and locals. These systems are sub-classified based on the trips served, the areas served, and the operational characteristics of the roadway. Typical cross sections are shown in Chapter 5.

The City of Sierra Vista utilizes the US department of Transportation Federal Highway Administration *Highway Functional Classification Concepts, Criteria and Procedures* 2013 edition as guidance for the classifications of roadways. This manual can be found at:

https://www.fhwa.dot.gov/planning/processes/statewide/related/highway_functional_classifications/fcauab.pdf.

2.1. DESIGN HOUR VOLUMES

2.1.1 DESIGN YEAR

The Design Year for future traffic volumes will be 20 years from the start of the design process. This calendar year will be rounded off to the nearest 5-year increment and coincide with a year for which volume projections based on City population projections from the State Demographer will be used for a given design year. The Design Engineer will confirm the design year for a project before starting the design process.

2.1.2 ADJUSTMENTS TO DESIGN YEAR ADT VOLUMES

For some roadway design projects, adjustments will be required to the volumes projected in coordination with the City of Sierra Vista Engineering Department. Adjustments will be required in anticipation of major land developments or significant changes to nearby roadways that will affect future traffic volumes expected on the roadway under design. Adjustments for other impacts shall be approved by the City Engineer before being undertaken by the Design Engineer.

2.1.3 DESIGN HOUR VOLUME

The Design Hour Volume (DHV) is the traffic volume used to determine the number of traffic lanes needed on the roadway. The DHV is from the Design Year, which shall be approved by the City. The following formula shall be used to determine the DHV:

$$DHV = ADT \times K$$

Where:

DHV = design hour volume of traffic (total, 2-way)

ADT = average 24-hour weekday, 2-way volume of traffic

K = ratio of design hour volume to ADT

(See Table 2.1 for K values to use for rural and urban roadway classifications.)

The number of lanes for each direction of traffic for an interim roadway is determined by the traffic impact analysis. However, the interim roadway shall be designed for conversion to the ultimate section determined by classification.

For special activity centers such as recreational areas, factories, sports arenas, etc., other values of the above factors will be used. It is also recognized that special traffic conditions may or will exist that require modification of the above factors. In these two sets of cases, the different factors must be documented and approved for use by the City Engineer.

2.1.4 TURNING MOVEMENT PERCENTAGES

At major intersections and at driveways leading to major activity centers, the design hour turning volumes are important in determining the intersection capacity, resulting number of lanes, and the storage length for exclusive turning lanes required for each approach. For intersections being reconstructed and that are in fully developed areas, existing turning movement percentages will be collected in the field and are assumed to be the same for the future design year. For new intersections or for those significantly impacted by new land developments or major changes to nearby roadways, existing and projected traffic data along with engineering judgment will be used to reassign vehicle trips on nearby street networks to derive the turning movements at project intersections.

Turning movements must be analyzed for both a.m. and p.m. peak hours at project intersections so that the maximum turning or through volumes can be determined for each approach. In the absence of other data, it can generally be assumed that the ‘background’ street network intersection turning movements will be opposite and equal for the a.m. and p.m. peak hours. In certain areas of such as large retirement communities, the peak hours may in fact occur around mid- day rather than at typical morning and evening rush hour periods. Therefore, it is important for the Design Engineer to obtain sufficient existing traffic counts by hourly variation to accurately identify and quantify project intersection turning movement volumes for the design year.

2.1.5 OTHER TRAFFIC VOLUME REDUCTION FACTORS

Vehicle trip (traffic volume) reductions for future transit ridership or other transportation modes are generally not permitted. Reductions for “passer-by or’ diverted’ trips are allowed as per the Institute of Transportation Engineers (ITE) Trip Generation Manual (latest revision) but must first be approved by the City. Trip reductions for special land uses utilizing travel demand management strategies will be considered on a case-by-case basis. However, the factors used must be fully and accurately documented to The City’s satisfaction.

2.1.6 CAPACITY ANALYSIS

Software using the current Highway Capacity Manual (HCM) procedures will be used to determine the capacity and resulting number of lanes for roadway design project street sections and intersections. For rural street sections with existing or planned traffic signals more than a mile apart, the appropriate section of the HCM will be used. For urban or suburban areas where traffic signals are at or less than a mile apart, it will be assumed that the signalized intersection capacity will control the design of the roadway segments.

The number of through lanes on street sections must be consistent with the number of through lanes at adjacent intersections. For capacity and lane determination, major intersections are assumed to be signalized for the design year. The signalized intersection section of the HCM will be used for the analysis. The default values of the peak hour factor (PHF), percentage of trucks, and saturation flow rate will be used. Other input criteria will be those equal to existing or future traffic conditions and approved by the City Engineer.

2.1.7 FUTURE TRAFFIC VOLUMES

Future traffic volumes shall be used to ensure that the road has enough traffic carrying capacity. The general unit of measure for traffic on a road is the ADT, the total volume of traffic in a given time period divided by the number of days in that time period. The future ADT shall be derived from the standard City of Sierra Vista Projected 2% growth rate for the engineer's judgement of growth patterns in the area.

The traffic volume during a period of time shorter than a day shall be used for design purposes, reflecting peak hour periods.

The directional design hour volume is the traffic volume for the rush hour period in the peak direction of flow. Use directional distribution factors based on existing traffic counts. If this information is not available it should be assumed that 60% of the traffic is going in one direction. For a more detailed analysis of intersection and road capacity, procedures as described in the intersection portion of this manual and the latest version of the HCM should be used.

2.2 TRAFFIC IMPACT STUDIES

Traffic impact studies shall be prepared using the procedures outlined in the latest update of the City's Traffic Impact Statement Requirements.

This policy is to provide for consistency in the preparation of traffic impact studies using certain established criteria. It has been prepared to assist consultants, developers, and others interested in evaluating traffic impacts within the City's jurisdiction. Developers and their engineering consultants are invited to discuss proposed projects with City Staff prior to beginning the analysis. This is to enable discussion and determination of parameters to be used and to open communications between City staff and the developer or consultant. Such communication will help in creating land uses with traffic characteristics that are in the entire community's best interests.

2.2.1 Crosswalks

Crosswalks shall not be installed unless a traffic engineering study determines that one is warranted per the MUTCD/ADOT and shall be installed per the same.

2.2.2 Traffic Signals

Traffic signals shall not be installed unless a traffic engineering study determines that one is warranted per the MUTCD/ADOT and shall be installed per the same.

Chapter 3

This chapter intentionally left blank

Chapter 4 Design Procedure

4.1 BASIC CRITERIA

4.1.1 ROAD CLASSIFICATION

Roadway classification is based on the guidelines presented in the USDOT Federal Highway Administration Highway Functional Classification Criteria, and Procedures document. These road classifications are reflected in the City of Sierra Vista Traffic circulation plan. If the classification is not identified, the Design Engineer must submit a classification for approval.

4.1.2 DESIGN VEHICLE

The design vehicle is the largest vehicle likely to use the road with considerable frequency or a vehicle with special characteristics that must be considered in designing the road. The design vehicle will affect the radii at intersections and the radii of turning roadways. It will also affect the climbing lane requirements on two lane roads. Unless otherwise specified, all roadways and intersections will be designed to accommodate a WB-50 design vehicle as defined in the 2004 5th edition of the AASHTO publication A Policy on Geometric Design of Highways. Other design vehicles shall be as defined in the most current edition of the AASHTO publication A Policy on Geometric Design of Highways.

4.1.3 DESIGN FOR FUTURE TRAFFIC VOLUMES

The primary design consideration for roadways is the handling of vehicular traffic. When streets are built or reconstructed, they will be designed with sufficient traffic handling capacity to accommodate the future level of traffic volumes. Section 2.2 Design Hour Volumes and the MCDOT Traffic Impact Procedures describe in greater detail the procedure to be followed in determining the capacity of roadways and intersections used in the design process.

While the functional classification approved for a roadway will govern the basic cross sectional elements, additional through or left turn lanes, auxiliary right turn lanes, acceleration lanes, and similar design features may be required. The City may direct the designer to do a detailed capacity analysis to determine the need for additional or auxiliary lanes.

4.1.4 TOPOGRAPHY

The topography of the area shall be determined by a site visit and available topographic maps. The terrain shall be classified as level, rolling, or mountainous. Level terrain is when highway sight distances are or could be made adequate without major construction requirements. This generally includes short grades of no more than 1 or 2 percent. Rolling terrain is when natural slopes consistently rise and fall with grades of up to 6.0% for lengths of 700 feet. Mountainous terrain is when changes in the ground's elevation with respect to a road are abrupt. Mountainous terrain has greater than 15% slopes on the U.S.G.S. 7.5-Minute Series Maps.

4.1.5 DEVELOPMENT OF PLANS AND SPECIFICATIONS

- A. Project design and construction, unless otherwise indicated, shall be in accordance with the latest edition and the most current revision of the following publications:
1. City of Sierra Vista Standard Details for Public Works Construction as Distributed by the City of Sierra Vista.
 2. Where City of Sierra Vista Standard details are not available: Maricopa Association of Governments Uniform Standard Specifications and Details for Public Works Construction as distributed by the Maricopa Association of Governments (MAG).
 3. Maricopa County Department of Transportation Supplement to the Maricopa Association of Governments Uniform Standard Specifications and Details.
 4. Manual on Uniform Traffic Control Devices for Streets and Highways as distributed by the U.S. Department of Transportation, Federal Highway Administration, as amended and approved by the Arizona Department of Transportation.
 5. A Policy on Geometric Design of Highways and Streets as distributed by the American Association of State Highway and Transportation Officials (AASHTO).
 6. Roadside Design Guide as distributed by the American Association of State Highway and Transportation Officials (AASHTO).
 7. Highway Capacity Manual and the current Highway Capacity Software, as distributed by the Transportation Research Board.
 8. Roundabouts: An Informational Guide, Second Edition, Transportation Research Board (TRB), National Cooperative Highway Research Program (NCHRP) Report 672, research sponsored by AASHTO in cooperation with the U.S. Department of Transportation, Federal Highway Administration.
 9. Materials Preliminary Engineering and Design Manual, Third Edition, March 1989, with current revisions, as distributed by the Arizona Department of Transportation.
 10. Drainage Policy as stated in the City of Sierra Vista Development Code and this document.
 11. Stormwater Compliance Requirements and Recommended Procedures for Construction and Maintenance Activities as published by the Maricopa County Department of Transportation.
 12. AASHTO LRFD Bridge Design Specifications as published by the American Association of State Highway and Transportation Officials
 13. Manual for Condition Evaluation of Bridges as distributed by American Association of State Highway and Transportation Officials (AASHTO).
 14. Standard Specifications for Structural Supports for Highway Signs, Luminaires and Traffic Signals as published by American Association of State Highway and Transportation Officials (AASHTO).
 15. CADD Standards as published by the Maricopa County Department of Transportation.
 16. Information Guide for Roadway Lighting as distributed by the American Association of State Highway and Transportation Officials (AASHTO).
 17. Guide for the Development of Bicycle Facilities, as distributed by AASHTO.
 18. MCDOT Traffic Impact Procedures.
 19. MCDOT Pavement Marking Manual.
 20. MCDOT Traffic Signing Manual.
 21. MCDOT Traffic Signal Design Manual.
 22. MCDOT Earthwork Guidelines.
 23. Designing Walkable Urban Thoroughfares: A Context Sensitive Approach, Institute of

Transportation Engineers (ITE).

24. Urban Bikeway Design Guide, National Association of City Transportation Officials (NACTO)

4.2 CONSTRUCTION DRAWINGS

4.2.1. Public Works Improvement Plans Required

- A. The developer or subdivider shall be responsible for having a registered professional engineer in the State of Arizona prepare a complete set of public works improvement plans, for the construction of public improvements, when required, which are satisfactory to the City Engineer.
- B. Public works improvement plans submitted in accordance with the provisions of Sections [151.18](#) or [151.19](#) shall be reviewed and approved by the City. Improvement plan checklists can be obtained from the City's website. The public works improvement plans must be stamped "Approved for Construction" by the City Engineer before any right-of-way permits may be issued or construction commences.
- C. The City of Sierra Vista has delegation authority from the Arizona Department of Environmental Quality (ADEQ) to approve water and sewer infrastructure. If the City of Sierra Vista is to perform ADEQ review, applications shall be submitted with the final improvement plans. Blank applications can be obtained at the City website.

4.2.2. Landscape Improvement Plans Required

- A. Landscaping plans for plantings, irrigation, and related improvements in the public right-of-way shall be submitted in accordance with the provisions of Chapter 9.

4.2.3. Public Works Improvement Plans

- A. Public Improvement Plans shall be submitted to the Community Development Department in an electronic format readable to the City.
- B. All specifications and references required by the City's construction standards and specifications shall be shown on the construction drawings. A completed copy of the Public Works checklist shall accompany all submittals for review.
- C. Plans shall be drawn at a horizontal scale of 1" = 40' and a vertical scale of 1" = 4', or an appropriate scale approved by the City. Drawings shall be oriented so that north is at the top of the page. However, when the preceding requirement proves to be impractical, then north shall be oriented to the right side of the page. North and scale must be identified on all plans.
- D. Profiles shall show existing and proposed elevations along center lines of all streets as well as the edge of any new and existing pavement and all gutter lines.
 - (1) When a proposed street intersects an existing street(s), the drawings shall show the elevations within a 200-foot radius of the intersection at the centerline.
 - (2) Existing grades shall be shown on 25-foot intervals and new grades on 50-foot intervals.
- E. Plans and profile sheets shall show the following information:
 - (1) The locations and typical cross-section of street pavements including curbs and gutters (both sides), sidewalks, drainage easements, rights-of-way, manholes, light poles, and catch basin inlets.
 - (2) The locations of street trees and the location of replacement trees for those to be removed during development.
 - (3) The location, size, direction of flow, and invert elevations of existing and proposed sanitary sewers, storm water system, and fire hydrants.

Sierra Vista Modified Maricopa County Roadway Design Manual

- (4) A blue stake alert and reference any other utility/improvement plans.
- (5) Radii of all curves, lengths of tangents, and central angles on all streets shall be shown.
- F. Sanitary sewerage and water systems shall be shown on the same set of drawings. A separate detailed water plan shall also be submitted. Water plans shall be stamped "approved" by the Water Company before they will be reviewed by the City Engineer.
- G. Location, size, elevation, and other appropriate description of any existing or proposed facilities or utilities shall be shown on the drawings. In addition, all elevations shall be referred to the City's local datum.
- H. Title, name, address, stamp, registered seal, signatures of the engineer and surveyor, and date, including revision dates, shall be shown on the drawings.

4.2.4 Improvement Standards.

All required public works improvements shall be designed and constructed in accordance with the latest revision of the Uniform Standard Specifications for Public Works Construction and the Uniform Standard Details for Public Works Construction as compiled by the Maricopa Association of Governments (MAG), and the City of Sierra Vista Public Works Engineering Design Standards and Drawings, as modified and adopted by the Council. Other standards pertaining to any required improvements shall be approved by the City.

4.2.5 Inspection and Testing of Public Works Improvements

All public works improvements constructed in the public right-of-way shall be constructed to the standards above and are subject to the inspection and approval of the City Engineer. Construction in any public right-of-way, public easement, and/or public drainageway shall not be commenced until a right-of-way permit has been issued by the City Engineer for such construction; and if work has been discontinued for any reason, it shall not be resumed until approval has been obtained from the City Engineer. A maintenance and construction bond may be required with the right-of-way permit application if the project estimated cost exceeds \$5,000 as stated in Section §91.23 of the City Code.

1. The permittee shall be responsible for having a person who is authorized and certified under Arizona Revised Statutes (ARS) to perform quality control materials testing and conduct the testing of all materials used in the construction of public works improvements. Any failed quality assurance testing performed by the City shall be paid by the Developer.
2. The results of all tests conducted during construction shall be provided to the City Engineer prior to the final inspection.

4.3 SURVEY AND DATA ACQUISITION

4.3.1 COORDINATE SYSTEM - DATUMS

A. LINEAR UNITS

International Feet (ift) where 1 foot = 0.3048 meters exact.

B. HORIZONTAL DATUM

The project horizontal datum shall be The Cochise County, Arizona Low Distortion Projection based on the North American Datum of 1983 - 1992 epoch NAD83 (1992).

C. VERTICAL DATUM

North American Vertical Datum of 1988 (NAVD 88) as measured using NAD83 (1992) ellipsoid height and the latest NGS Geoid model.

4.3.2 CONTROL POINTS AND BENCH MARKS

A. DEFINITIONS

Primary Control: Control points that are used to establish Secondary Control.

Secondary Control: Control points that are established on the project site used for horizontal and vertical control.

Project Bench Mark(s): Can refer to a Secondary Control point or a monument used for vertical control only. The Project Bench Mark shall be within the project limits.

B. MONUMENTATION

Permanent survey monuments consisting of a brass cap set in concrete shall be installed to designate street center lines to be located at all angle points, points of curvature, and at all street intersections. Regardless the size of the project there shall be a minimum of three Secondary Control points set on the project. For projects over 1500 feet, a Secondary Control point/Bench Mark shall be set every 500 feet along the project corridor. In all cases, the Secondary Control points shall be set in such a location as to avoid destruction by future construction. The physical monument shall not be shorter than 16” in length and at least a 5/8 inch rebar. Other suitable monuments may be a chiseled cross or nail in a structure believed not to be disturbed during the construction. A brass cap will be permanently affixed to the rebar and stamped with the project number, control point name, year and LS number. These will serve as both horizontal and vertical control for the project.

C. OBSERVATIONS

1. Horizontal

All control points shall be directly geodetically tied to or surveyed from a City approved Primary Control point. A Global Navigation Satellite System (GNSS) solution shall be used. Coordinates shall be derived by a mean of a minimum of at least three (3), 90 second observations, with at least one observation taken with a 4-hour separation of time from the other two observations.

2. Vertical

One of the Secondary Control points set near the center of the project shall be chosen to hold the GNSS derived elevation fixed using the aforementioned vertical datum parameters. A closed level loop shall be run through all the remaining Secondary Control points set. The maximum permissible closure shall not exceed the National Geodetic Surveys, Vertical Control Network Standards of Third Order Classification as published by the Federal Geodetic

Sierra Vista Modified Maricopa County Roadway Design Manual

Control Committee under the Standards and Specifications for Geodetic Control Networks. The results of the closed bench circuit shall be adjusted using acceptable surveying methods and the final elevations published on the design plan set. All field notes shall be submitted to The City in standard field book format.

The adjusted *leveled* elevations shall be assigned to each Secondary Control point and be reported in the coordinate table on the Geometric sheet of the design plans.

4.3.1 DATA COLLECTION

A. OBSERVATIONS

1. Monuments
 - a. Confirm the description is the same that is in the point database if not survey as a newly found monument.
 - i. GPS: Survey with a 3 epoch observations. If the position matches within 0.10 horizontally and 0.15 vertically, accepted. If outside the tolerance, survey as a new monument.
 - ii. Conventional: Survey at least 2 times.
2. Topography (Topo)
 - a. GPS: Survey with a 3 epoch observation
 - b. Conventional: Survey with 1 forward face observations.

B. SURVEY CODES

The current approved MCDOT Survey Code list shall be used for all for control points and topographic features surveyed.

C. POINT RANGE

The current MCDOT Survey Point Range Format shall be used.

D. PHOTOGRAPHS

All monuments shall be photographed with a vicinity image and a close up of each monument. If the monument is not easily identifiable in the vicinity photo, there shall be a rod or lath indicating its position. Each photo shall be placed in a folder labeled with the individual point number. (For example, if a monument was surveyed as point 1000 and two photos were obtained then a folder called "1000" shall be created with both photos placed in it.

4.3.2 PUBLIC LAND CORNERS, PROPERTY, AND RIGHT-OF-WAY MONUMENTS

- A. All controlling United States Public Land Survey System (USPLSS) monuments set during the original government survey(s) prior to disposal\patent of the public lands, and shown on the official plat(s) of the GLO, BLM, or other authoritative federal agency, including but not limited to section corners, 1/4 (quarter), 1/16, 1/64, etc. corners, lot corners, witness corners, reference monuments, angle points, closing corners and amended monuments, affecting the project, shall be observed with two 90 second GNSS observations with independent initializations.

Any USPLSS corners that are lost or obliterated shall be reestablished per, Restoration of Lost

Sierra Vista Modified Maricopa County Roadway Design Manual

or Obliterated Corners and Subdivision of Sections by the U.S. Department of the Interior, Bureau of Land Management, the current Minimum Standards for Arizona Land Boundary Surveys by Arizona State Board of Technical Registration and Maricopa Association of Governments (MAG).

The position of each monument surveyed shall be reported in the coordinate table on the Geometric sheet in the design plans. This shall include controlling USPLSS monuments set or found for the project, and all supporting USPLSS monuments used to reestablish lost corners that affect the project.

- B. If the contract stipulates that the Right-of-way or parcel lines shall be determined, the position of each monument surveyed shall be reported in the coordinate table on the Geometric sheet in the design plans. A Results of Survey drawing may also be required to be recorded pursuant to Arizona Revised Statutes (ARS) and/or Arizona State Board of Technical Registration (AZ BTR) statute\rules.

4.3.3 TOPOGRAPHICAL FEATURES (FOR BASE MAP GENERATION)

- A. All topographic features affecting the project shall be surveyed. These include, but not limited to roadways, bridges, curbs, gutters, sidewalks, barriers, fences, gates, irrigation/storm drainages, pipes, railroads, pavement markings, trees (type and size), vegetation and all utility (water, gas, electric, storm, sanitation, traffic, blue stake markings, etc.) features, etc.
- B. Sufficient elevations on topographic features and spot elevations (along the project road and crossroads alignments) shall be obtained to create an accurate Digital Terrain Model (DTM) for design purposes.
- C. Topographic features and spot elevations shall be collected in cross section format. Cross sections shall be taken at every 100 feet along tangents, 50 feet along curves, with additional sections taken at grade breaks. Horizontal and vertical limits shall extend 25 feet beyond proposed right-of-way left and right, with right-of-way elevations given at average natural ground. Cross sections shall extend 300 feet beyond the beginning and end of the project.
- D. Existing edges of pavements, major drives, traffic signals, traffic striping, and traffic signs shall be surveyed to 500 feet beyond each end of the project.
- E. The elevation of all ditch flow lines, tops of banks, tops of linings, high water marks, culverts, pipe inverts, manhole rims and inverts, tops of headwalls, building finished floor elevations, water valves at operating nut and valve box cover, irrigation bench mark monuments, and similar features shall be obtained and clearly noted.
- F. Field measurements and notations for irrigation and drainage facilities shall include: feature description, type, structure sizes, shapes, material, type, direction and invert elevations of all pipes and culverts.

- G. Field measurements and notations for fences, walls, and gates shall include: type and sizes, material, and direction.
- H. Features and/or elevations that could affect or be affected by the design shall be recorded and shown. Porches, signs, overhangs, clearances, electrified signs, and motorized gates shall be noted. Significant dimensions of the objects must be recorded.
- I. Major drainage features shall require additional cross sections, both upstream and downstream of the project 300 feet left and right of centerline.
- J. When applicable, floor elevations shall be shown on the plans for houses and buildings within a minimum of 125 feet from the centerline.
- K. All marked Blue Stake lines and features shall be part of the topographic information obtained.
- L. The existence and direction of overhead lines is to be noted. Any potential conflict with overhead lines (electric or communication cables) requires an observation at the sag (or low) point.
- M. Elevations beyond the proposed right-of-way line must be recorded in the field notes for driveways and irrigation facilities that may require alterations beyond the right-of-way. Elevations shall also be obtained and recorded in the field notes for all parking areas on adjacent property to ensure that the property will properly drain in conjunction with new roadway grades.

4.3.4 DRAWING GENERATION (SURVEY MAPS)

A. SURVEY MAPPING

Survey maps shall be produced in accordance with the MCDOT CADD Standards.

At a minimum two (2) drawings shall be produced: a coordinate geometry drawing and a topographic drawing.

- 1. The coordinate geometry “BC” (aka COGO) drawing shall contain all pertinent monuments found or set, along with all Public Land breakdowns, parcel and centerline representations. Example formats are available on the MCDOT web site under CADD standards in the .dwg file. The drawing shall contain but is not limited to the following:
 - a. Labeling of the streets, monuments (number, description, representation (i.e. section corner, etc.)), bearing and distances of all key lines.
 - b. Although primarily the responsibility of the Design Engineer, if a construction centerline is requested as part of the surveying firm’s scope of services, appropriate ties (bearing and distance) shall be annotated to found existing monuments, preferably public land corners and/or street intersection monuments that will not be affected by the new road design or construction.
 - c. Metadata Statements
 - d. Coordinate List of all found, set and calculated points. Identify which monuments are to be used for horizontal control and vertical control (construction benchmarks).

- e. Records List - All recorded and unrecorded documents used to determine parcel breakdown and centerline positioning.
 - f. When monuments are not found or accepted, provide a detailed explanation of how the new position was determined and identify the documents used in the determination.
2. The topographic drawing “BE” shall contain the topography of the existing terrain and all pertinent features.

B. HORIZONTAL ACCURACY

Survey accuracies shall meet or exceed the current American Land Title Association (ALTA) Accuracy Standards, (0.07 ift + 50 ppm) and shall never be reported at anything less than the 95% confidence interval.

C. VERTICAL ACCURACY

Not more than 10 percent of the contour elevations tested shall have an error more than one-half the contour interval. In checking elevations taken from the map, the apparent vertical error may be decreased by assuming a horizontal displacement within the permissible horizontal error for a map of that scale.

The Contour Interval shall be no greater than 1/2 foot unless otherwise indicated in the contract.

4.3.5 PHOTOGRAPHS

A. MAPPING

In the case of complex structures that are difficult to represent or convey in the topographic drawing, photos shall be obtained and labeled to aid in the design process.

B. MONUMENTS

All monuments set (excluding panel points) or found shall be photographed. A minimum of three (3) photos shall be taken;

1. Close up Photo. The monument shall be in focus and capture any relevant stamping or identification.
2. General photo. A photo of the monument and the surrounding area.
3. Vicinity Photo. A photo of the monument with horizon on the shot. If available a street sign or other identifiable feature should be included in the photo. Either a lath, survey rod or something equivalent should be in the photo if it is not apparent where the monument lies in the photo.

Each monument surveyed shall have a separate folder created with its monument point number and the corresponding photos placed in said folder.

4.3.6 DELIVERABLES

Upon completion of the survey mapping, the following shall be submitted to The City of Sierra Vista

A. NON DIGITAL MEDIA

1. Field book(s): Clear, complete, fully indexed field notes with all abbreviations explained, an alignment/geometrics layout clearly designating point numbers and descriptions, bench

Sierra Vista Modified Maricopa County Roadway Design Manual

mark level notes, any necessary details drawn for clarification and a listing of all digital files submitted with full descriptions. The cover shall be signed and sealed by an Arizona Registered Land Surveyor.

2. Any unrecorded surveys or as-built plans NOT obtained from The City.

B. DIGITAL MEDIA

Directories and subdirectories shall be created so as to produce an organized structure that is easily followed to obtain the copied files. The following items shall be copied into the appropriate directories of a CD with the City project name, work order number, land surveyors stamp and signature on the label;

1. Data Collection Files

All files associated with the data collection, including but not limited to:

- a. GNSS project(s) (i.e. Trimble Geomatics Office, Trimble Business Office, etc.)
- b. Level runs.

2. CADD

All files associated with generating the survey maps, including but not limited to:

- a. Raw Data – The appropriate raw data for the software utilized.
- b. Coordinates – Comma delimited ASCII format listing point number, northing, easting, elevation, descriptor codes, and notes.

3. Monument Coordinate List

Comma delimited file: Point Number, Latitude, Longitude, Ellipsoid Height, Northing, Easting, Elevation, Date Surveyed and Monument Description.

4. Photographs

All photos taken of the project.

5. Miscellaneous

Any and all files that were used in conjunction with generating the survey maps.

4.4 GEOTECHNICAL DESIGN

4.4.1 ANALYSIS AND REPORT

The Geotechnical Engineer shall analyze the results of field explorations and laboratory tests and prepare a written report on the findings.

The report shall be suitable for reproduction and shall include:

- A. Project description, to include: purpose of report, project limits and location, type of proposed improvements, construction limits, general existing conditions, i.e., topography, vegetation, drainage, areas of potential environmental concerns, etc.;
- B. A narrative description of the general geology of the project area. This would typically include a description of the source and nature of deposits, depth/ thickness and composition of strata making up the subgrade soil profile, estimated location of bedrock, quality of bedrock if it is within five feet of subgrade or foundations, location and variation in groundwater table, if it is within the zone of design interest, and areas of potential problems (springs, unstable slopes, expansive soils, corrosive soils, contaminated soils, earth fissure, subsidence, etc);
- C. For projects where substantial cuts and fills (greater than 2 feet) are anticipated, a site topographic map shall be prepared showing proposed cuts and fills, anticipated grades, locations of drainage and irrigation facilities, i.e. storm drains, drain fields, dry wells, detention/retention ponds, channels, etc.
- D. Logs of test borings, a site plan showing their locations (vertical and horizontal) and a description of procedures and equipment used in the boring program.
- E. Results of laboratory tests and a description of test methods;
- F. A discussion of the foundation system or alternative systems recommended for consideration for the project;
- G. Recommended foundation bearing pressures or capacities, foundation depths and geometrics, and criteria for design for the resistance of lateral loads;
- H. Earth pressures and other criteria for the design of retaining walls and other earth retaining structures;
- I. Estimated foundation settlements;
- J. Recommended cut and fill slopes;
- K. Recommended values for earthwork shrink/swell and ground compaction factors;
- L. Guide specifications for recommended construction methods or materials that differ from the Maricopa Association of Governments (MAG) Uniform Standard Specifications and Details for Public Works Construction as supplemented by MCDOT;
- M. Special treatment recommended for any expansive soils, “collapsing” soils, man-made fills or other moisture-sensitive materials that may be present beneath the site.
- N. Pavement structure sections.
- O. Professional interpretations of the foregoing as appropriate.
- P. A summary of the findings with appropriate exhibits to indicate the geotechnical considerations involved and setting forth recommendations with project criteria as specified elsewhere.

4.4.2 SOIL PARAMETERS FOR TRENCH SHORING DESIGN

Soil parameters for trench shoring designs shall be provided in the geotechnical report.

4.4.3 BORROW MATERIAL

Define quality requirements for imported fill material for construction of roadway fills. The recommendation is to be expressed in terms of the percent passing the 200 sieve and the plasticity index.

4.4.4 SUBMITTALS

The geotechnical investigation report shall be included in the construction documents submitted to The City for review.

4.5 BRIDGE DESIGN

Placement of manholes or points of access within the roadway pavement on or at the ends of bridges shall be avoided.

4.5.1 REQUIRED DESIGN DOCUMENTS

The Design Engineer shall perform/provide the following:

- A. Survey to establish topographic mapping; locate significant features, such as existing bridge or other structures; define width and profile of canal or channel; and to establish ties to section corners, benchmarks, etc.
- B. Hydrology and Hydraulic Analysis (not needed for the irrigation canal bridges or grade separations). The report shall include a scour analysis and shall determine the optimum size bridge opening, define the resulting effect on the upstream floodplain during the Design Flood, and determine design parameters for upstream and downstream improvements. The Conditional Letter of Map Revisions (CLOMR) per FEMA requirements shall be included.
- C. Bridge Selection Report to determine the recommended type of bridge structure. At least two types of structures shall be evaluated.
- D. Canal Profile Study to determine canal alterations.
- E. Soil Boring Report (Geotechnical Report) to determine foundation requirements and soil parameters for the bridge foundation design. At least one boring per foundation unit. Depth of borings shall be a minimum 20 feet below the bottom of the foundation structure. Bore hole locations shall be within ten feet (10') of the pier/abutment footprint as indicated in Appendix C of the Materials Preliminary Engineering and Design Manual distributed by the Arizona Department of Transportation.
- F. Structure Design Calculations.
- G. Construction Plans based on using the current MAG construction specifications and details as supplemented by MCDOT.
- H. All standards referenced in the construction documents other than MAG, MCDOT, or ADOT are to be included within the plans or special provisions.
- I. Quantity Calculations and Estimated Costs.
- J. Cross Sections used to calculate earthwork volumes.
- K. Special Provisions.

- L. A bridge load rating report with ratings in both LFR and LRFR.

4.5.2 CONSTRUCTION PLANS

Plans shall as a minimum include the following:

- A. Standard Title Sheet with Vicinity Map and Project Location.
- B. General Notes Sheet with Index of Drawings and Approximate Quantities Table.
- C. Location Plan - showing existing topography, hydraulic data, existing and proposed profiles, proposed bridge in plan and profile, existing bridge general details, and geometric controls including bench marks and ties to section corners. Access routes and easements for inspection and maintenance activities shall be identified.
- D. General Plan of Bridge - showing plan and elevation of proposed bridge, and typical section. Depending on the scale and size of the project, a separate sheet may be needed for the typical section.
- E. Soil Boring Log - showing location of borings, top of boring hole elevation, and pertinent soils data.
- F. Foundation Plan and Details.
- G. Abutment Details.
- H. Pier Details.
- I. Beam or Girder Layout.
- J. Beam or Girder Details.
- K. Deck and Approach Slab Details.
- L. Pour Sequence and negative moment reinforcing for continuous bridges.
- M. Miscellaneous Bridge Details.
- N. Screed Elevations at span tenth points of each girder, each span.
- O. Canal Lining or Flood Protection Details.

The plans are to provide the bridge detail information in a consecutive order as the bridge structure is built. Avoid unnecessary repetition of information. All explanatory notes are to be written in plain English to be clearly understood by the construction crew. The above provided list and order of plan sheets is an example only. It can, and should be, modified as needed to accommodate the project size and complexity of the bridge structure.

4.6 HAZARDOUS MATERIALS

When the design requires the use of any materials at the project site that are hazardous substances which may be harmful to humans, animals, vegetation, ground and surface water, and the environment and/or are regulated under the Hazardous Material Transportation Act, the Toxic Substances Control Act, the Resources Conservation and Recovery Act, or the Comprehensive Environmental Response, Compensation, and Liability Act the Design Engineer shall clearly identify all such occurrences. Identification of hazardous substances shall be included on all affected drawings and in the Special Provisions. The Design Engineer shall provide in the Special Provisions a listing of the hazardous materials cross-referenced to the plans. The Special Provisions shall include information needed by the Contractor to comply with the Hazardous Material Handling specifications contained in the MAG Specifications as modified by the MCDOT Supplement (Section 107.5).

Sierra Vista Modified Maricopa County Roadway Design Manual

Asbestos-cement pipe is to be treated as a hazardous material. New installations of asbestos-cement pipe shall not be installed in City right-of-way.

4.7 RIGHT-OF-WAY

The design plans shall identify right-of-way and easement requirements. The plans shall show and dimension existing right-of-way, new right-of-way, and easements. The type of each easement shall be shown on the plans.

RIGHT-OF-WAY DOCUMENTS

For all City capital projects, the title reports, legal descriptions, final project right-of-way strip maps, and related items will be the City’s responsibility, unless otherwise specified in the project scope of work.

4.8 UTILITIES

4.8.1 UTILITIES

Relocation of existing utilities shall be avoided, except where necessary due to construction or drainage requirements. Design of culverts, irrigation facilities, and/or storm drain systems should avoid or minimize any disruption of utility service.

The location of existing and new underground utilities and culverts shall be shown on the paving plans, paving profiles, culvert profiles, storm drain profiles, private irrigation profiles, cross-sections, and other locations where a potential utility conflict may occur.

All above ground utilities and signal poles shall be offset behind future sidewalk in urban areas. In rural and urban areas, new or relocated above ground utilities shall be located as close to the right-of-way line as is practical.

Utility manhole frames and covers, clean outs, and valve boxes shall not be located in any curb ramp, curb, or gutter.

Table 4-1 – Minimum Cover Depth For Underground Utilities ¹

Description	Arterial Street	Collector Street	Local Street & Alley	Unpaved (No Curb & Gutter)
POWER				
0-600 Volts	36"	36"	24"	48"
601-7200 Volts	42"	42"	42"	54"
12KV (local dist)	42"	42"	42"	54"
12KV (30 feeder)	48"	48"	48"	60"
Street Light Circuit	36"	36"	36"	48"
GAS				

Sierra Vista Modified Maricopa County Roadway Design Manual

Low Pressure Gas (60PSI and below)	36"	36"	36"	48"
High Pressure Gas (60PSI and above)	48"	48"	48"	60"
WATER / IRRIGATION / STORM DRAIN				
Water Line > 12" diameter	48"	48"	48"	60"
Water Line < 12" diameter	36"	36"	36"	48"
Irrigation Lines	36"	36"	36"	48"
Storm Drain Lines	18"	18"	18"	30"
TELECOMMUNICATIONS				
Fiber Optic	48" ²	48"	48"	60"
Copper Cable	36" ³	36"	36"	48"
Copper / Fiber Service Drops	36"	36"	36"	48"
CATV				
Fiber Optic	48" ¹	48"	48"	60"
Coaxial Cable	36" ²	36"	36"	48"
Coaxial Service Drops	36"	36"	36"	48"
<p>NOTE:</p> <ul style="list-style-type: none"> • The City may approve deviations from these standards under unusual and compelling circumstances. • All roadway crossings must be within conduit. • All non-metallic facilities must be accompanied by a tracer wire. • Cover is defined as the difference in elevation between the top of the line or pipe and the ultimate gutter grade of the roadway if paving will follow or to top of existing pavement. • For facilities outside of the proposed or existing roadway limits cover is defined as the difference in elevation between the top of the line or pipe and the natural or regraded ground surface, whichever is less. 				

¹ Minimum depths should comply with current regulatory standards if different than those show in Table 4-1.

² With warning tape, 60" depth when crossing or within fifteen feet (15') of roadway.

³ If direct buried, must be fifteen feet (15') beyond the edge of roadway.

4.9 EARTHWORK

The establishment of profile grades shall consider existing terrain, existing and future improvements, drainage, and other factors.

Chapter 5 Geometric Design Standards

5.1. CROSS SECTIONS

Cross sections for roadways per functional classifications are provided in Figures 5.1 through 5.14. Special use cross sections for superelevation conditions are provided in Figure 5.15.

5.1.1 LANE WIDTHS

Consult the standard cross sections (Figures 5.1 through 5.14) for standard lane widths and other relevant cross section geometry. For analyzing non-typical situations, Table 5.1 shows appropriate ranges of roadway lane and shoulder widths. The Design Engineer must submit a written statement providing rationale to justify why they can't meet preferred widths to The City of Sierra Vista Engineering Division for consideration. to The City Engineering Division shall approve or deny said request.

The length of the transition to match the standard cross section must be determined using the road width transition tapers as specified in the standards (Chapter 5, Section 20, "Transition Tapers").

TABLE 5.1: LANE WIDTHS		
Lane Type	Preferred Width (feet)	Minimum Width (feet)
Parking Lane	10	8
Right Through Lane Without Curb	12	11
Right Through Lane With Curb and Without Bike Lane	14	12
Right Through Lane With Curb and With Bike Lane	12	12
Left Through Lane With Median Curb	12	12
Other Through Lanes	12	11
Painted Center TWLTL**	14	12
Left Turn Lane	12	11
Right Turn Lane Without Curb	12	10
Right Turn Lane With Curb	14	12
Shoulder***	12	10
Bike Lane with curb and gutter (edge line to gutter joint)	6	3
Bike Lane without curb and gutter (edge line to pavement edge)	6	4
NOTE: Outside lane width is measured to face of curb.		
** Two-way left turn lane.		
*** Shoulder width includes paved and graded portions of shoulder.		

5.1.2 CROSS SLOPE

The desired cross slope on all pavement types is 0.02 foot per foot, with 0.01 foot per foot as the desired minimum and 0.03 foot per foot as the desired maximum. Pavement cross slopes at signalized intersections may be reduced to 0.005 foot per foot to obtain intersection profiles compliant with design speed requirements. Changes in pavement cross slope shall be accomplished using transition sections with edge of pavement profile gradients the same as required for superelevation transitions (see Section 5.10.4).

Inverted crown designs are prohibited. When pavements are resurfaced the cross slopes should be kept within the above limits.

Graded shoulders except rural local roads should slope 0.05 foot per foot (20:1) downward from the adjacent pavement edge. For rural local roads the graded shoulders should slope 0.10 foot per foot (10:1) away from the adjacent pavement.

The paved portions of the shoulders shall be constructed as an integral part of the travel lanes and have the same cross slope and structural section as the traveled lanes. The remaining unpaved portion of the shoulder is to comply with the graded shoulder requirements.

NOTES:

- ① TYPE A VERTICAL CURB AND GUTTER, SIERRA VISTA DETAIL, SV220-1-A.
- ② SHARED-USE PATH, SIERRA VISTA DETAIL, SV231.
- ③ TYPE A VERTICAL CURB AND GUTTER, SIERRA VISTA DETAIL, SV220-1-A OR TYPE A SINGLE CURB, SIERRA VISTA DETAIL, SV222.
- ④ PAVED/LANDSCAPED MEDIAN OR TURN LANE. PAVED MEDIAN AREAS TO BE FLUSH WITH TOP OF ADJACENT CURB. FINISHED GRADE OF UNPAVED MEDIANS SHALL BE CONSTRUCTED ONE INCH BELOW TOP OF ADJACENT CURB.
- 5. CROSS SECTION CAN BE MODIFIED PER CITY ENGINEER.

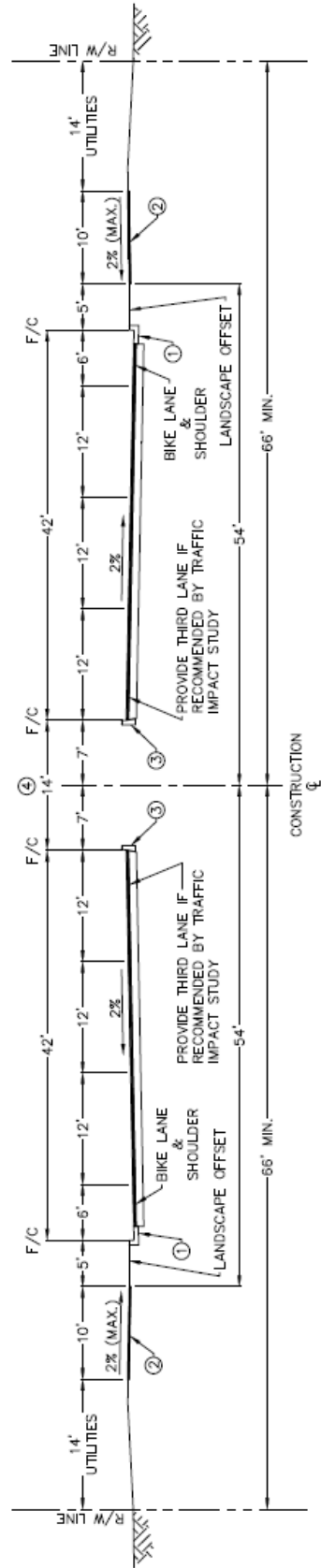

MODIFIED MCDOT ROADWAY DESIGN MANUAL, FIGURE 5.8

REVISED:	SCALE:
08/2023	NTS
STANDARD TYPICAL SECTION	

CITY OF SIERRA VISTA
PRINCIPAL ARTERIAL

CITY OF SIERRA VISTA
1011 North Coronado Drive
Sierra Vista, AZ 85635
520-458-5775



NOTES:

- ① TYPE A VERTICAL CURB AND GUTTER, SIERRA VISTA DETAIL, SV220-1-A.
- ② SHARED-USE PATH, SIERRA VISTA DETAIL, SV231.
- ③ MATCH EXISTING GRADE AT R/W, SLOPE VARIES.
- ④ TWO WAY LEFT TURN LANE OR CENTER MEDIAN WITH SIERRA VISTA DETAIL, SV220-1. LANDSCAPING SHALL BE FLUSH W/TOP OF CURB.
5. EXCEPTIONS TO THESE STANDARDS RELATED TO EXISTING CONDITIONS / PHYSICAL CONSTRAINTS MAY BE PROVIDED UPON THE APPROVAL OF THE CITY ENGINEER.

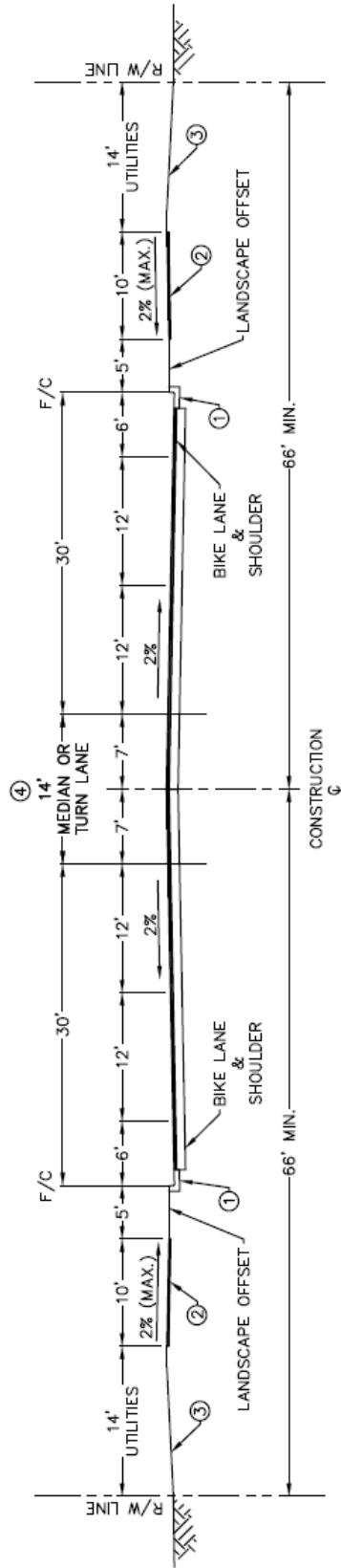

MODIFIED MCDOT ROADWAY DESIGN MANUAL, FIGURE 5.9



CITY OF SIERRA VISTA
 1011 North Coronado Drive
 Sierra Vista, AZ 85635
 520-458-5775

CITY OF SIERRA VISTA
 MINOR ARTERIAL

REVISED: 10/2023
 SCALE: NTS

STANDARD TYPICAL SECTION

NOTES:

- ① TYPE A VERTICAL CURB AND GUTTER, SIERRA VISTA DETAIL, SV220-1-A.
- ② SHARED-USE PATH, SIERRA VISTA DETAIL, SV231.
- ③ MATCH EXISTING GRADE AT R/W, SLOPE VARIES.
- ④ TWO WAY LEFT TURN LANE OR CENTER MEDIAN WITH SIERRA VISTA DETAIL, SV220-1. LANDSCAPING SHALL BE FLUSH W/TOP OF CURB.
5. EXCEPTIONS TO THESE STANDARDS RELATED TO EXISTING CONDITIONS / PHYSICAL CONSTRAINTS MAY BE PROVIDED UPON THE APPROVAL OF THE CITY ENGINEER.

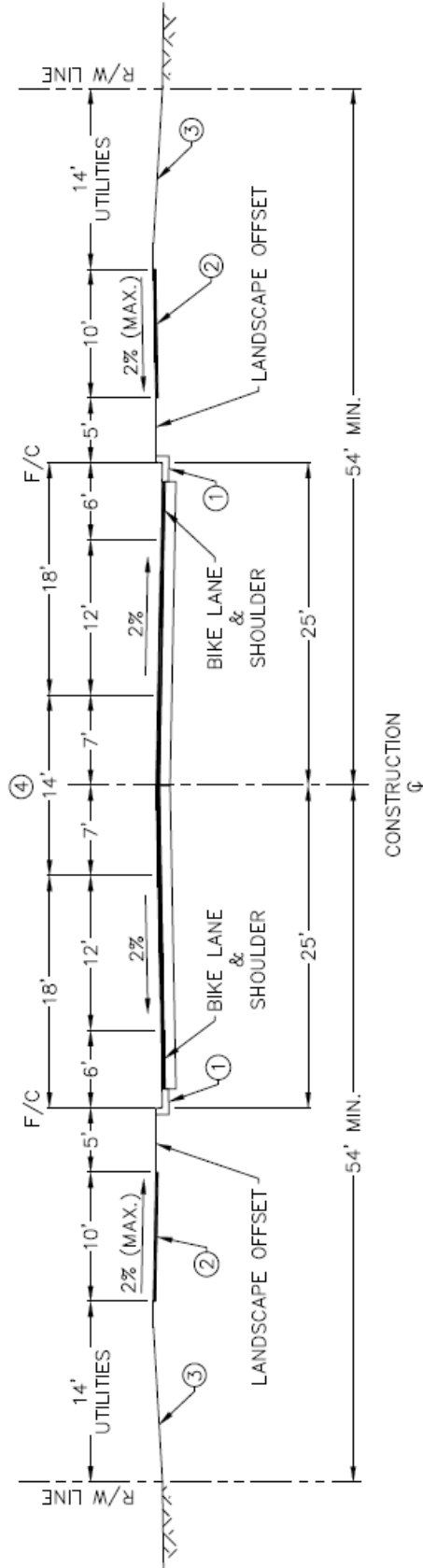

MODIFIED MCDOT ROADWAY DESIGN MANUAL, FIGURE 5.10

	CITY OF SIERRA VISTA 1011 North Coronado Drive Sierra Vista, AZ 85635 520-458-5775	CITY OF SIERRA VISTA MAJOR COLLECTOR	REVISED: 08/2023 SCALE: NTS	STANDARD TYPICAL SECTION
---	---	---	--------------------------------	--------------------------

NOTES:

- ① TYPE A VERTICAL CURB AND GUTTER, SIERRA VISTA DETAIL, SV220-1-A.
- ② SIDEWALK, SIERRA VISTA DETAIL, SV230.
- ③ MATCH EXISTING GRADE AT R/W, SLOPE VARIES.
4. EXCEPTIONS TO THESE STANDARDS RELATED TO EXISTING CONDITIONS / PHYSICAL CONSTRAINTS MAY BE PROVIDED UPON THE APPROVAL OF THE CITY ENGINEER.

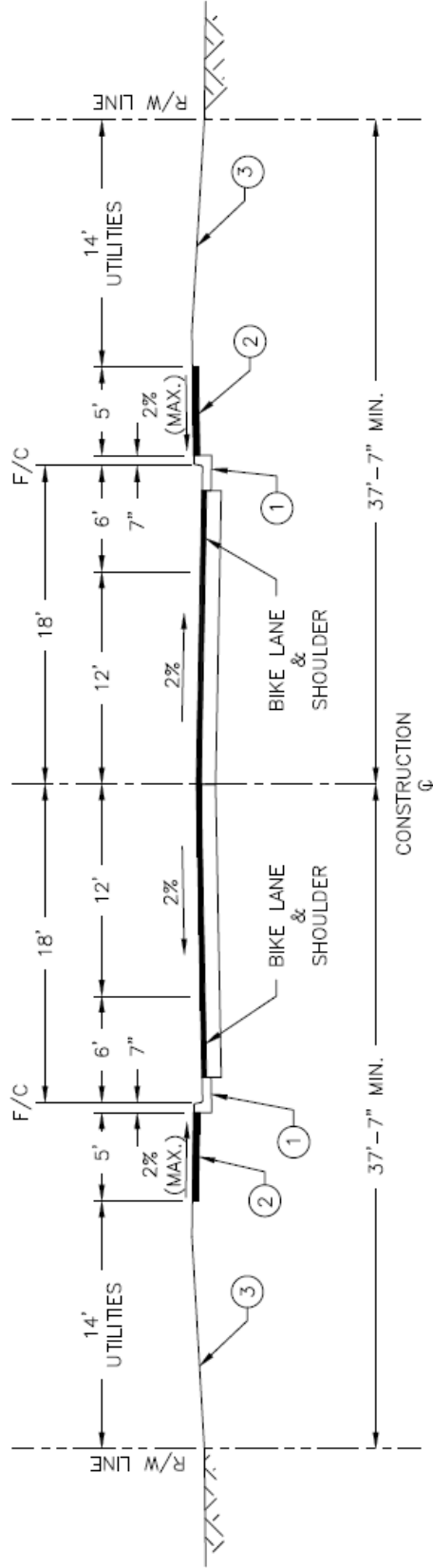

MODIFIED MCDOT ROADWAY DESIGN MANUAL, FIGURE 5.11

 <p>Sierra Vista EXTRAORDINARY SKIES. UNCOMMON GROUND.</p>	<p>CITY OF SIERRA VISTA 1011 North Coronado Drive Sierra Vista, AZ 85635 520-458-5775</p>	<p>CITY OF SIERRA VISTA MINOR COLLECTOR</p>	<p>REVISED: 08/2023 SCALE: NTS</p>
	<p>STANDARD TYPICAL SECTION</p>		

NOTES:

- ① TYPE C ROLLED CURB AND GUTTER, SIERRA VISTA DETAIL, SV220-1-C.
- ② SIDEWALK, SIERRA VISTA DETAIL, SV230.
- ③ MATCH EXISTING GRADE AT R/W, SLOPE VARIES.

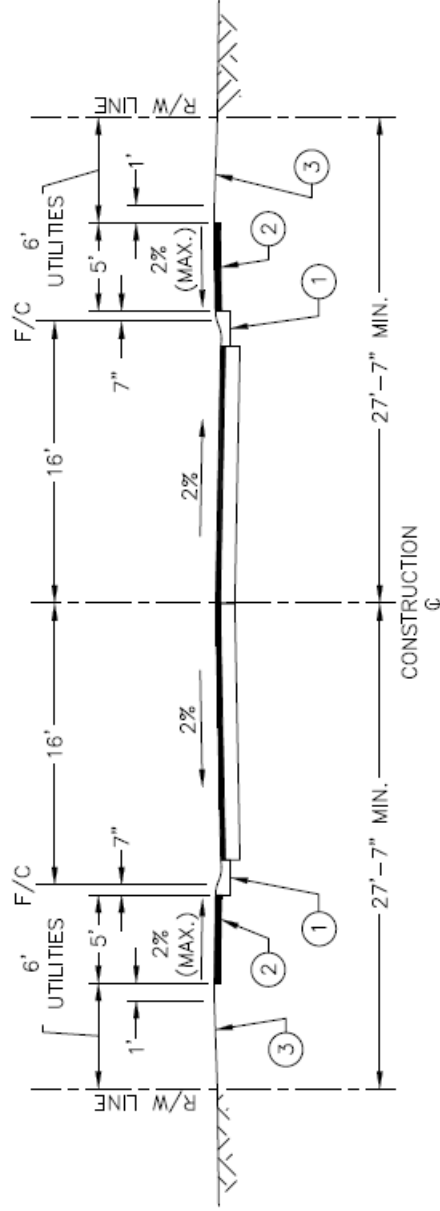

MODIFIED MCDOT ROADWAY DESIGN MANUAL, FIGURE 5.12

 <p>Sierra Vista EXTRAORDINARY SKIES. UNCOMMON GROUND.</p>	<p>CITY OF SIERRA VISTA 1011 North Coronado Drive Sierra Vista, AZ 85635 520-458-5775</p>	<p>CITY OF SIERRA VISTA LOCAL RESIDENTIAL ROAD</p>	<p>REVISED: 08/2023</p>	<p>SCALE: NTS</p>
	<p>STANDARD TYPICAL SECTION</p>			

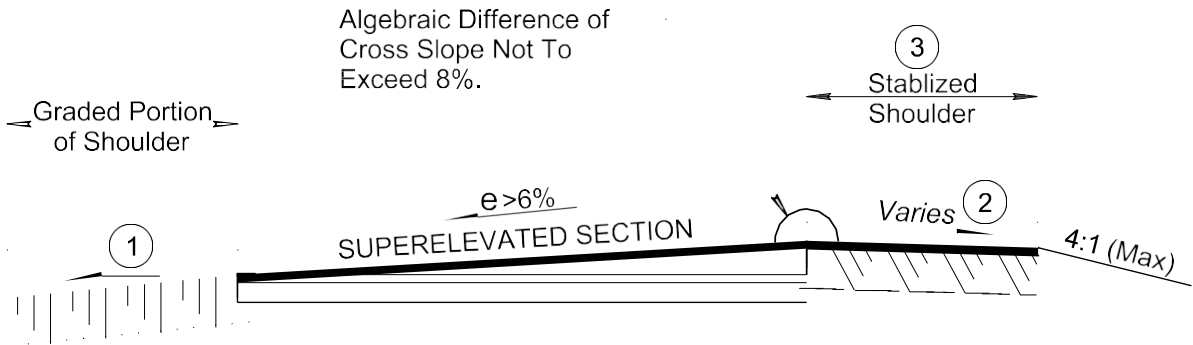
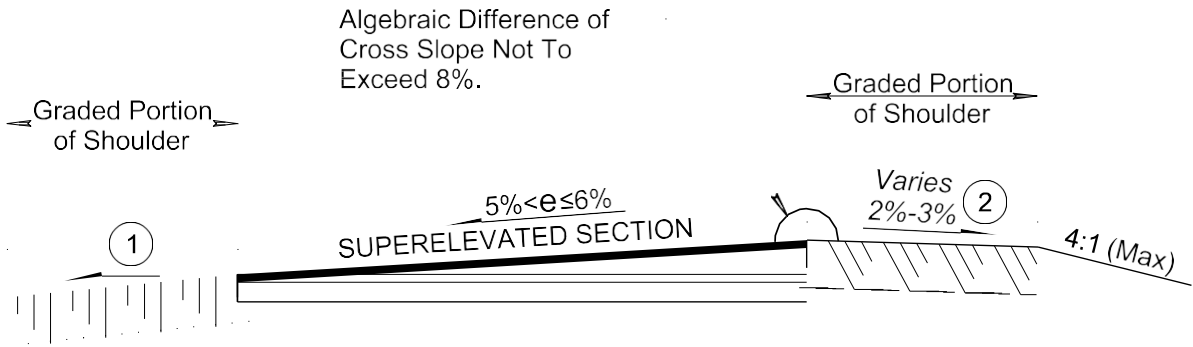
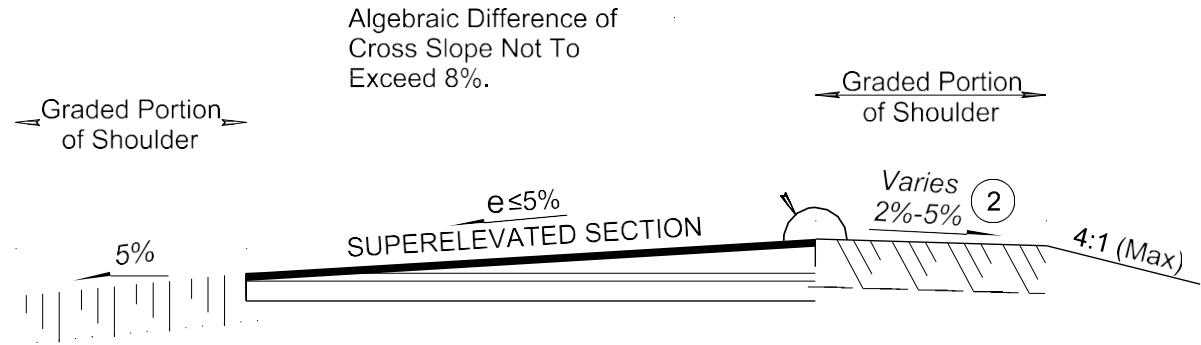

- (1) Match Pavement Slope.
- (2) Cross Slope of Graded Shoulder Can Vary in Superelevated Sections to Maintain 8% Maximum "Roll-Over" Cross Slope Difference.
- (3) Bituminous Stabilization or Asphalt Concrete Surface Required For Slopes < 2%.

FIGURE 5.15 - SUPERELEVATED CROSS SECTIONS

5.5 DESIGN SPEEDS

The design of geometric features such as horizontal and vertical curves will depend upon the design speed selected for the street. The choice of the design speed is primarily determined by the street classification. The design speed is the maximum recommended speed at which reasonable safe operation of a vehicle can be maintained over a specific section of a road when conditions are so favorable that the design features of the road govern. Design speeds for the various classifications of roads are found in Table 5.2 for rural conditions and Table 5.3 for urban conditions. The use of design speeds other than those shown on these two tables must be approved by the City Engineer.

It is important to remember that design speeds are 5-10 mph over anticipated posted operation speeds. Local roads designed using the minimum design speed may have a posted speed equal to the design speed.

TABLE 5.2: MINIMUM DESIGN SPEEDS FOR RURAL ROADWAYS BY CLASSIFICATION AND TYPE OF TERRAIN		
Classification	Terrain	Design Speed (mph)
Rural Parkway	Level	65
	Rolling	60
	Mountainous	55
Rural Principal Arterial	Level	65
	Rolling	60
	Mountainous	55
Rural Minor Arterial	Level	60
	Rolling	55
	Mountainous	45
Rural Major Collector	Level	50
	Rolling	45
	Mountainous	40
Rural Minor Collector	Level	45
	Rolling	40
	Mountainous	35
Rural Local		35 Desirable 25 Minimum

Local roads located in level terrain shall use a design speed of 35 mph. In rolling and mountainous terrain, a reduction in the design speed will be acceptable when the terrain makes the horizontal and/or vertical geometric alignment impractical at the 35 mph design speed. When natural slopes consistently rise and fall with grades above 4.0% a reduction of the design speed to 30 mph is acceptable. When natural slopes consistently rise and fall with grades above 8.0% a reduction of the design speed to 25 mph is acceptable.

TABLE 5.3: MINIMUM DESIGN SPEEDS FOR URBAN ROADWAYS BY CLASSIFICATION AND TYPE OF TERRAIN		
Classification	Terrain	Design Speed (mph)
Urban Parkway	Level	55
	Rolling	50
	Mountainous	45
Urban Principal Arterial	Level	55
	Rolling	50
	Mountainous	45
Urban Minor Arterial	Level	55
	Rolling	50
	Mountainous	45
Urban Major Collector	Level	40
	Rolling	30
	Mountainous	25
Urban Minor Collector	Level	40
	Rolling	30
	Mountainous	25
Urban Local		35 Desirable 25 Minimum
Frontage Road (Residential)		35 Desirable 25 Minimum

Local roads in residential subdivisions may use a design speed of 30 mph. A reduction in the design speed to 25 mph is acceptable in mountainous terrain where natural slopes consistently rise and fall with grades above 8.0%.

5.10 HORIZONTAL CURVES

5.10.1 GENERAL CONTROLS

Flat curves should be provided wherever possible with the use of the minimum radius of curvatures restricted to, the most critical conditions. Alignment must be consistent. Sudden changes from flat to sharp curves and long tangents followed by sharp curves shall not be used.. Likewise, reverse curves should be avoided.

The horizontal alignment development process can possibly introduce trial alignments which have curvature, superelevation, or superelevation transition carried onto or through a structure. Such alignments should be avoided... Special authorization shall be obtained from the City Engineer or an authorized representative for an exception.

For small deflection angles, curves should be sufficiently long to avoid abrupt transitions. Curves should be at least 500 feet long with a central angle of 5 degrees or 10 times the design speed, whichever is less. The minimum length should be increased 100 feet for each degree decrease in the central angle.

5.10.2 SUPERELEVATION RATES

The use of superelevation will depend on the classification of the roadway being designed.

Superelevation's are discouraged along local residential streets with design speeds at 35 MPH or less.

Use the appropriate e_{max} table in the AASHTO publication 'A Policy on Geometric Design of Highways and Streets' for the design superelevation rate and design speed.

$$R_{min} = \frac{V^2}{15(0.01e_{max} + f_{max})}$$

Where

V = Design Speed (mph)

e = Superelevation rate (percent)

f = Side Friction Factor

R = Curve Radius (feet)

Values for the side friction factors to be used for design shall be as recommended in the AASHTO publication ‘A Policy on Geometric Design of Highways and Streets’ (for the 2011 6th edition see Figure 3-6 or Table 3-7).

5.10.3 INTERSECTION CURVES

Minimum radii for curves at intersections shall be based on superelevation, design turning speed, and side friction factors. The side friction factors for various speeds shall not exceed those shown in Table 5.5. The minimum radius applies to the inside edge of the innermost travel lane. Table 5.5 provides a sample of superelevation rates; the minimum curve radius will depend on the superelevation rate of the actual intersection curve being designed.

Design (turning) speed, V (mph)	10	15	20	25	30	35	40
(Assumed average running speed - mph)	10	14	18	22	26	30	34
Side friction factor, f	0.38	0.32	0.27	0.23	0.20	0.18	0.16
Assumed minimum superelevation, e	-0.02	0.00	0.00	0.02	0.02	0.04	0.04
Total e + f	0.36	0.32	0.27	0.25	0.22	0.22	0.20
Calculated minimum radius, R (ft)	19	47	99	167	273	371	485
Suggested curvature for – design:							
Suggested Design Radius (minimum ft)	25	50	100	170	275	375	485

NOTE: For design speeds of more than 40 mph, use values for open highway conditions.

5.10.4 SUPERELEVATION TRANSITION

Superelevation runoff is the general term denoting the length of highway needed to accomplish the change in cross slope from a section with adverse crown removed to a fully superelevated section, or vice versa. Tangent runout is the general term denoting the length of highway needed to accomplish the change in cross slope from a normal crown section to a section with the adverse crown removed, or vice versa. For added comfort and safety, the superelevation runoff should be established uniformly over a length adequate for the likely operating speeds. To be pleasing in appearance, the runoff pavement edges should not be distorted as the driver views them.

The length of tangent runout is determined by the amount of adverse crown to be removed and the rate at which it is removed. The rate of removal should be the same as the rate used to effect the superelevation runoff.

The minimum superelevation runoff length is determined from the rotated pavement width and the relative gradient between the profile along the axis of rotation and the outermost pavement edge. The difference in longitudinal gradients varies with the design speed. The maximum relative gradients between the profiles for rotating a twelve-foot pavement width is given in Table 5.6.

Design Speed (mph)	Maximum Relative Gradients (%)	Equivalent Maximum Relative Slope
25	0.70	1:143

Sierra Vista Modified Maricopa County Roadway Design Manual

30	0.66	1:152
35	0.62	1:161
40	0.58	1:172
45	0.54	1:185
50	0.50	1:200
55	0.47	1:213
60	0.45	1:222
65	0.43	1:233

Curves are preferably designed with 60 to 80 percent of the superelevation runoff length located on the tangent section adjacent to the curve. Superelevation is usually attained by revolving a crowned pavement about the centerline profile. Where drainage is a major control, superelevation may be attained by revolving the pavement about an edge.

In the design of divided highways, roads, and parkways, the inclusion of a median in the cross section will influence the superelevation runoff design. For medians 8 feet or less in width, the whole of the traveled way, including the median, is often superelevated as a plane section. Superelevation runoff lengths for these divided roads should be increased in proportion to the total width, including the median. For medians 8 feet or more in width, the median is often held in a horizontal plane and the two pavements separately are rotated around the median edges or, where applicable, around the inside gutter lines.

The superelevation runoff length for rotation of pavement widths greater than twelve feet is increased and the increase is a function based on the runoff length of a single 12 foot lane.

$$n_1 b_w = \frac{1}{2} \left[\frac{x}{12} + 1 \right] \quad \text{Equation 5.10.3}$$

Where

$n_1 b_w$ = Superelevation length increase relative to one rotated 12-foot lane

x = Rotated pavement width

Superelevation runoff lengths for horizontal curves of various e_{\max} values are available in the AASHTO publication 'A Policy on Geometric Design of Highways and Streets'. The AASHTO indicated values for runoff lengths should be considered minimums values. Pavement-edge profiles should be smooth-flowing without abrupt changes. 

5.10.5 SIGHT DISTANCE ON HORIZONTAL CURVES

Objects such as walls, cut slopes, buildings, guardrail, and vegetation located on the inside of a curve may cause sight obstructions that will require adjustment of the horizontal alignment if they cannot be removed. The Design Engineer is to check for sight obstructions and make adjustments as needed to provide adequate sight distance. The assumed criteria used for stopping sight distance is an eye height 3.50 feet and a 2.0 foot object height.

The stopping sight distance is measured along the centerline of the lane being checked for sight obstructions. For horizontal curves the stopping sight distance is measured along the centerline of the inside lane of the curve; the sight line is a straight line connecting the beginning and end points of the stopping sight distance. The AASHTO Policy on Geometric Design of Highways and Streets shall govern Sight Distances on Horizontal Curves.

FIGURE 5.16 – HORIZONTAL SIGHT LINE OFFSET

The AASHTO Policy on Geometric Design of Highways and Streets shall govern Horizontal Sight Line Offsets.

5.11 VERTICAL ALIGNMENT

5.11.1 VERTICAL CURVES



Algebraic difference in grades without a vertical curve on continuous roadways shall be equal to or less than the values specified for the following conditions:

- 0.3% Equal to or greater than 55 mph design speed
- 0.5% Equal to or greater than, 40 mph, but less than 55 mph design speed
- 1.0% Less than 40 mph design speed
- 2.0% Local residential street or alley

Multiple short grade breaks are not an acceptable alternative to a vertical curve.

Minimum sight distances shall be provided in all cases. The AASHTO Policy on Geometric Design of Highways and Streets shall govern Vertical Alignments.

5.11.2 GRADES

The AASHTO Policy on Geometric Design of Highways and Streets shall govern all grades for roadway design.



TABLE 5.7: MAXIMUM VERTICAL GRADES (%)						
LOCAL ROADS – DESIGN SPEED (mph)						
Terrain	25	30	35	40	50	60
Level	7	7	7	7	6	5
Rolling	11	10	10	10	8	6
Mountainous	15*	14	13	13	10	---
RURAL COLLECTOR ROADS** - DESIGN SPEED (mph)						
Terrain	35	40	45	50	55	60
Level	---	---	7	6	6	5
Rolling	---	8	8	7	7	6
Mountainous	10	10	10	9	9	8
URBAN COLLECTOR ROADS** - DESIGN SPEED (mph)						
Terrain	25	30	35	40	45	50
Level	---	---	---	9	8	7
Rolling	---	11	10	10	9	8
Mountainous	13	12	12	12	11	10
RURAL ARTERIAL ROADS – DESIGN SPEED (mph)						
Terrain	45	50	55	60	65	70
Level	-	-	-	3	3	3
Rolling	-	-	5	4	4	4
Mountainous	7	7	6	6	5	5
URBAN ARTERIAL ROADS – DESIGN SPEED (mph)						
Terrain	35	40	45	50	55	60

Sierra Vista Modified Maricopa County Roadway Design Manual

Level	---	---	-	6	5	5
Rolling	---	---	-	7	6	6
Mountainous	---	---	9	9	8	8
<p>* Designs with grades exceeding 15% for a distance not exceeding 500 feet with a grade not exceeding 18% will require approval of the local fire district in addition to a design exception</p> <p>** Maximum grades shown for rural and urban conditions of short lengths (less than 500 ft) may be 1% steeper on one-way down grades.</p>						

5.11.3 CREST VERTICAL CURVES

Minimum lengths of crest vertical curves shall be determined by sight distance requirements. The basic formulas for length of a parabolic vertical curve in terms of algebraic difference in grade and sight distance is as follows:

<p>When S is less than L</p> $L = \frac{AS^2}{100(\sqrt{2h_1} + \sqrt{2h_2})^2}$	<p>When S is greater than L</p> $L = 2S - \frac{200(\sqrt{h_1} + \sqrt{h_2})^2}{A}$
--	---

Where:

- L = length of vertical curve, ft
- A = algebraic difference in grades, percent
- S = sight distance, ft
- h₁ = height of eye above roadway surface, ft
- h₂ = height of object above roadway surface, ft

the assumed height of eye and height of object shall be 3.5 feet and 2.0 feet, respectively.

TABLE 5.8: SIGHT DISTANCE DESIGN PARAMETERS FOR CREST VERTICAL CURVES	
Height of eye (h ₁)	h ₁ = 3.5'
Height of object (h ₂)	h ₂ = 2.0'
When S is less than L	L = AS ² / 2,158
When S is greater than L	L = (2S) - (2,158 / A)

Once the curve lengths have been established for design speeds, the term K is computed, which is L/A. This permits determining the minimum curve length by the equation: L = KA, where S is less than L. The selection of design curves is facilitated because the required length of the curve in feet is equal to K times the algebraic difference in grades in percent, L = KA. Table 5.9 provides design K values for various design speeds for crest vertical curves based on stopping sight distance.

The above values of K that are derived when S is less than L can also be used without significant error where S is greater than L. As a practical minimum, the length of the vertical curve is equal in feet to 3 times the design speed in miles per hour.

There is a level point on crest vertical curves. Special attention is needed in these cases to ensure proper pavement drainage near the apex of crest vertical curves. For K values greater than 167, drainage must be carefully designed.

TABLE 5.9: DESIGN CONTROLS FOR CREST VERTICAL CURVES			
Design Speed (mph)	Stopping sight distance on level terrain (ft)	Rate of vertical curvature, K ^a	
		Calculated	Design
25	155	11.1	12
30	200	18.5	19
35	250	29.0	29
40	305	43.1	44
45	360	60.1	61
50	425	83.7	84
55	495	113.5	114
60	570	150.6	151
65	645	192.8	193

^a Rate of vertical curvature, K, is the length of curve per percent algebraic difference in intersecting grades (A). $K=L/A$

5.11.4 PASSING SIGHT DISTANCE ON CREST VERTICAL CURVES

Design values of crest vertical curves for passing sight distance differ from those for stopping sight distance because of the different height criterion. The 3.5 feet height of objects results in the following specific formulas with the same terms as above:

When S is less than L, $L = AS^2/ 2,800$

When S is greater than L, $L = (2S) - (2,800 /A)$

For minimum passing sight distances, the required lengths of crest vertical curves are substantially longer than those for stopping sight distances. Generally, it is not practical to design crest vertical curves to provide for passing sight distance because of high costs where crest cuts are involved and the difficulty of fitting the required long vertical curves to the terrain, particularly for high-speed roads. Passing sight distance on crest vertical curves may be feasible, and should be incorporated when practicable, on roads with an unusual combination of low design speed and gentle grades or, higher design speeds with very small algebraic differences in grades.

5.11.5 SAG VERTICAL CURVES

When a vehicle traverses a sag vertical curve at night, the portion of highway lighted ahead is dependent on both the position of the headlights, and the direction of the light beam. Assumed design values are a headlight height of 2 feet and a 1-degree upward divergence of the light beam from the longitudinal axis of the vehicle. For overall safety, the light beam distance is nearly the same as the stopping sight distance. Accordingly, it is pertinent to use stopping sight distances for the different design speeds. Basic formulas for the length of a sag vertical curve are:

When S is less than L, $L = AS^2 / (400 + 3.5 S)$

When S is greater than L, $L = (2S) - (400 + 3.5S) / A$

where:

L = length of sag vertical curve, in feet

S = light beam distance, in feet – (stopping sight distance for headlight control).

A = algebraic difference in grades, percent

There is a level point on sag vertical curves. Special attention is needed in these cases to ensure proper pavement drainage near this point on sag vertical curves.

Once the curve lengths have been established for design speeds, the term K is computed which is L/A . This permit determining the minimum curve length by the equation: $L = KA$, where S is less than L. The selection of design curves is facilitated because the required length of the curve in feet is equal to K times the algebraic difference in grades in percent, $L = KA$. Table 5.10 provides design K values for various design speeds for Sag vertical curves based on headlight control.

The Design Engineer should consider the general appearance of vertical curves, especially for small or intermediate values of A. Minimum lengths of sag vertical curves are equal to 3 times the design speed, except for rural arterials which shall have a minimum length of 800 feet.

TABLE 5.10: DESIGN CONTROLS FOR SAG VERTICAL CURVES			
Design Speed (mph)	Stopping sight distance on level terrain (ft)	Rate of vertical curvature, K ^a	
		Calculated	Design
25	155	25.5	26
30	200	36.4	37
35	250	49.0	49
40	305	63.4	64
45	360	78.1	79
50	425	95.7	96
55	495	114.9	115
60	570	135.7	136
65	645	156.5	157

^a Rate of vertical curvature, K, is the length of curve per percent algebraic difference in intersecting grades (A). $K=L/A$

5.11.6 GENERAL CONTROLS

In addition to the above specific control for vertical alignment, there are several general controls that should be considered in design:

1. A smooth grade line with gradual changes, as consistent with the type of road and the character of the terrain, is preferable to a line with numerous breaks and short lengths of grades. Detailed

design values are the maximum grade and the critical length of grade; however, the manner in which they are applied and fitted to the terrain on a continuous line determines the suitability and appearance of the finished product.

2. The 'Roller-Coaster' or the 'hidden dip' type of profile shall be avoided.
3. Undulating grade lines, involving substantial lengths of momentum grades, should be appraised for their effect on traffic operation.
4. A broken-back grade line (two vertical curves in the same direction separated by short sections of tangent grade) shall be avoided.
5. On long grades it may be preferable to place the steepest grades at the bottom and lighten the grades near the top of the ascent or to break the sustained grade by short intervals of lighter grade instead of a uniform sustained grade that might be only slightly below the allowable maximum. This is particularly applicable to low-design-speed roads and streets.
6. Where intersections at grade occur on roadway sections with moderate to steep grades, it is desirable to reduce the gradient through the intersection. Such a profile change helps all vehicles making turns and serves to reduce potential hazards. See intersection general controls in Section 1 of Chapter 6. 

5.12 HIGHWAY ALIGNMENT

COMBINATION OF HORIZONTAL AND VERTICAL ALIGNMENT

The proper combination of horizontal and vertical alignments is obtained after an engineering study and consideration of the following general controls:

1. A vertical curvature superimposed on a horizontal curvature generally results in a more pleasing facility, but the resultant effect on traffic must also be analyzed.
2. A sharp horizontal curvature should not be introduced at or near the top of a pronounced crest vertical curve.
3. A sharp horizontal curvature should not be introduced at or near the low point of a pronounced sag vertical curve.
4. The horizontal curvature and profile should be made as flat as feasible at intersections where sight distance along roads is important, and vehicles may have to slow or stop.
5. Avoid a short tangent section on a crest vertical curve between two horizontal curves.

5.15 STOPPING SIGHT DISTANCES

The height criteria used for the stopping sight distance is based on an assumed driver's eye height of 3.5 feet and an object height of 2.0 feet.

For the passing sight distance, the height criteria is the same 3.5 feet high driver's eye height and an oncoming vehicle 3.5 feet high.

The minimum stopping and passing sight distances for nearly level roadways shall vary with the design speeds as indicate in Table 5.11.

TABLE 5.11: PASSING AND STOPPING SIGHT DISTANCES		
Design Speed (mph)	Stopping Sight Distance (feet)	Passing Sight Distance (feet)
25	155	450
30	200	500
35	250	550
40	305	600
45	360	700
50	425	800
55	495	900
60	570	1,000
65	645	1,100

For grades that exceed 2%, the stopping sight distance provided is to be at least equal to the values shown in Table 5.12. Values may be interpolated as necessary.

TABLE 5.12: GRADE ADJUSTED STOPPING SIGHT DISTANCES								
Design Speed (mph)	Stopping Sight Distance (feet) Downgrades				Stopping Sight Distance (feet) Upgrades			
	3%	6%	9%	12%	3%	6%	9%	12%
25	158	165	173	184	147	143	140	137
30	205	215	227	242	200	184	179	175
35	257	271	287	308	237	229	222	216
40	315	333	354	381	289	278	269	261
45	378	400	427	462	344	331	320	310
50	446	474	507		405	388	375	
55	520	553	593		469	450	433	
60	598	638	686		538	515	495	
65	682	728	785		612	584	561	

5.20 TRANSITION TAPERS



5.20.1 NARROWING TRANSITIONS

When a proposed roadway will directly connect with an existing roadway of a smaller width, it is necessary to install a transition taper between the two. Taper lengths on roads with a design speed less than or equal to 40 mph shall be:

$$L=WS^2/ 60$$

Where the design speed is greater than 40 mph:

$$L=WS$$

Where:

W = Offset from drivable through lane in feet

S =Design speed

L =Taper length

5.20.2 WIDENING TRANSITIONS

When transitioning from a narrow section to a wide section use an opening taper rate of 8:1 [L:W] minimum and 15:1 [L:W] maximum. Use an 8:1 [L:W] opening taper for design speeds of 30 mph or less and for design speeds of 50 mph or greater use a 15:1 [L:W] taper.

5.20.3 TRANSITION GEOMETRICS

Straight line tapers are to be used for uncurbed roadways. Reverse curves are to be used for curbed roadways.

5.25 CLEAR ZONES

5.25.1 GENERAL CRITERIA

- A. The clear zone is the lateral distance from the edge of the traveled way that is available for the safe use of errant vehicles. To protect clear zone integrity, the clear zone recovery area shall be within right-of-way. Rigid obstacles and certain other features within the recommended minimum clear zone recovery area shall be adjusted so that:
1. Obstacles which may be removed should be eliminated.
 2. Obstacles which may not be removed should be relocated laterally or to a more protected location.
 3. Obstacles which may not be moved should be reduced in impact severity. Breakaway devices and flattened side slopes offer such an improvement.
 4. Obstacles which may not be otherwise treated should be shielded by crash-worthy devices such as guardrail.

5.25.2 OBSTACLES

- A. Obstacles and features which need to be analyzed include such items as:
1. Rough rock cuts
 2. Boulders over 2 feet in diameter
 3. Streams or permanent bodies of water more than 2 feet deep
 4. Signs, traffic signals, and luminaire supports with a breakaway or yielding design with linear impulses greater than 1,100 lb-sec.
 5. Signs, traffic signals, and luminaire supports with a concrete base extending 6 inches or more above ground.
 6. Bridge piers and abutments
 7. Retaining walls and culverts
 8. Trees with an expected mature size greater than 4 inches in diameter
 9. Wood poles or posts with a cross sectional area greater than 16 square inches
 10. Culverts, pipes, and headwalls
 11. Embankments
 12. Fire hydrants
 13. Benches that are fixed to the ground.
 14. Non-Standard mailboxes

Above ground facilities of utility companies should be located outside of the clear zone and as near to the right-of-way as practical.

5.25.3 EMBANKMENTS

A. The design slope used for roadway embankments depends upon the existing terrain, available right-of-way, and safety considerations. Embankments shall have a minimum slope of 20:1 (5% grade) for drainage.

1. Embankment slopes that minimize clear zone distances for errant vehicle recovery are slopes of 6:1 (Horz:Vert) or flatter. This condition can often be met in level terrain and is the basis for the minimum right-of-way widths shown for rural typical sections on Figure 5.1 through Figure 5.6.
2. Embankment slopes with slopes greater than 6:1 but not exceeding 4:1 (Horz:Vert) are deemed recoverable slopes and require a larger clear zone recovery area. This slope range may require more than the minimum right-of-way shown for rural typical sections.
3. Embankment slopes that exceed 4:1 but do not exceed 3:1 (Horz:Vert) are classified as traversable not recoverable. These slopes are not included in the clear zone recovery area. The use of traversable non-recoverable slopes and the larger associated right-of-way width versus steeper slopes and a protective barrier depends on an evaluation of the safety and the economics of the various potential alternatives.
4. Slopes that exceed 3:1 (Horz:Vert) are considered non-traversable and require a protective barrier to prevent vehicle access. This condition is often found in mountainous terrain or when available right-of-way is restricted. Embankment slopes of 3:1 (Horz:Vert) or steeper shall provide an accessible slope maintenance area at least ten feet wide at the bottom of the slope. The cross slope for the slope maintenance area shall not exceed 10:1 (Horz:Vert). Slope maintenance areas shall be contained within right-of-way.

B. Roadway embankment slopes shall be contained within right-of-way.

5.25.4 CLEAR ZONE WIDTH

A. Urban Conditions

1. The clear zone width for rural conditions shall be maintained for urban conditions when practicable. The application of these urban conditions assumes lower operating speeds than rural conditions and require longitudinal curb lines to be located in conformance with the typical urban roadway cross sections (Figure 5.7 – Figure 5.14) for the roadway's designated classification.
2. For urban roadways where a six-foot (6') bicycle lane is provided, a clear zone width of four feet (4') shall be provided behind the face of curb that is free of all obstacles. For urban roadways without a bicycle lane, a six-foot width clear zone shall be provided behind the face of curb that is free of all obstacles.
3. At signalized intersections where curb returns are provided, signal poles should be placed a minimum six-foot (6') behind the face of curb.
4. If the required six-foot (6') width is found impractical a reduction of the clear zone to four feet (4') is acceptable with approval from City Engineer. The Design Engineer should prepare a design memo detailing the request.

B. Sidewalks and Pathways

A lateral two-foot clear distance shall be maintained between above ground obstacles and adjacent sidewalks and pathways, unless otherwise approved by The City.

5.25.5 VERTICAL CLEARANCE

All roadways shall maintain a minimum vertical clearance of 16-feet over the entire roadway width.

5.30 GUARDRAIL

5.30.1 PURPOSE

The primary purpose of a guardrail is to safely redirect an errant vehicle away from a roadside object or feature.

5.30.2 TYPE

Guardrail and bridge concrete barrier transitions shall be constructed per MAG Uniform Standard Specifications and Details as modified by the MCDOT Supplement to the MAG Uniform Standard Specifications and Details.

The use of special coatings on any guardrail component or the use of weathering steel requires specific approval from the City Engineer.

The type of treatment to mitigate roadside hazards shall take into consideration the cost to remove or reduce the hazard so that shielding is unnecessary compared with the cost of maintenance and installation of a barrier.

5.30.3 PLACEMENT

The guardrail should be set as far as practical from the edge of the traffic lanes.

The face of guardrail is usually installed along the edge of pavement alignment with the face of rail set not less than 2 feet from the edge of the driving lane.

The structural pavement section shall be extended to the face of rail with asphalt surfacing extending two feet beyond the back of post.

The face of the guardrail should be a minimum of 4.0 feet in front of any shielded object but when this distance is unattainable, stiffening of the guardrail shall be considered.

In fill sections, the back of the guardrail post shall be a minimum of 2 feet in front of the hinge point of the slope to ensure adequate lateral soil resistance for the posts during impact.

If a curb must be used with a guardrail, the face of the curb shall be behind or flush with the face of the guardrail. Vertical curbs higher than 4" shall not be used with guardrail.

5.30.4 END TREATMENTS

Ends of longitudinal barrier within the clear zone shall have crash worthy end treatments. Grading and paving limits for End Terminal layouts treatments shall be shown to scale on the plans per manufactures placement guidelines in accordance with MCDOT Standard Details.

5.30.5 BARRIER TRANSITIONS

Transition sections are necessary to provide continuity of protection when two different roadside barrier systems join, when roadside barriers join another barrier system (i.e., bridge rail), or when a roadside barrier is attached to or adjacent to a rigid object such as a bridge pier. Standard transition sections for attachment of guardrail to safety-shape barrier are shown in the Construction Standard Drawings.

5.30.6 EMBANKMENT/EXTRUDED CURB

Extruded curb in conjunction with embankment spillways and down drains shall be installed under non-curbed guardrail sections based on drainage calculations to prevent erosion and degradation of roadway shoulders and embankments. Other slope erosion protection solutions may be considered if they are more appropriate.

5.30.7 LENGTH

The length of need for guardrail shall be determined using procedures contained in AASHTO's "Roadside Design Guide, 2011." The length of need and its locations (the length of need point) shall be shown on the construction plans.

Proper protection for canal bridges approaches shall be provided. The Design Engineer shall coordinate with the water authority and obtain the water authority's approval for any solution involving realignment of the canal maintenance road or other canal facility. 

5.35 PAVEMENT EDGE TREATMENTS

The pavement edge for all asphalt roadways shall be protected by a safety edge, thickened edge, concrete curbing, or cutoff wall.

5.35.1 SAFETY EDGE

A safety edge shall be installed at the edge of asphalt pavement for all uncurbed roadways having a design speed of 40 mph or greater. The safety edge shall be installed at the edge of the asphalt pavement regardless of the distance between the pavement edge and the closest travel lane. When a roadway that requires a safety edge is overlaid, the overlay operation shall include installing a safety edge if none exists or overlaying an existing safety edge to produce a finished surface that complies with safety edge requirements.

5.35.2 ASPHALT THICKENED EDGE

An asphalt thickened edge shall be installed on all uncurbed roadways where a safety edge is not installed. Install an asphalt thickened edge:

- A. Along the edge of roadways having a design speed of less than 40 mph,
- B. At the termination of asphalt roadway pavement (requires MAG Detail 201, Type D),
- C. Edge of pavement behind guardrail.

5.35.3 CURBS

A. Vertical Curbs

Vertical curbs deter vehicle operators from driving onto areas not intended for vehicular use and helps to contain longitudinal street drainage. Vertical curbs shall only be used where the posted speed of the road is 45 mph or less.

Vertical curb and gutter shall be constructed in accordance with, MAG Standard Detail 220, Type A. The height in inches for dimension H shown in the Standard Detail is normally 6 inches.

MAG Type E and Type F Mountable Curb & Gutter is not permitted for use on public improvements.

B. Roll Curbs

Roll curb and roll curb and gutter shall be constructed in accordance with MAG Standard Detail 220. Sidewalk located behind roll curb shall use the concrete class and thickness at driveway crossing locations at residential driveways only. Rolled Curb and roll curb and gutter shall not be permitted for commercial driveways.

C. Ribbon Curbs

Ribbon curbs shall be constructed in accordance with MAG Standard Detail 220, Type B.

5.35.4 CURB RETURNS

The minimum radii for curb returns at street intersections shall be in accordance with Table 6.1.

Offsets for curb return radius points may be necessary to achieve throat widening required to accommodate the design vehicle turning path. An offset curb return may use a taper or large radius curve to transition to the standard curb location.

Curb returns shall be vertical curb and gutter, (four or six inches high) consistent with the height of adjacent connecting curb. The curb height within the curb return shall match the height of the adjacent connecting curb. Transitioning from different heights of curb may occur at curb ramps and shall meet ADA compliance. Transitioning from different types of curb shall be done in curb transitions. The curb transition shall not extend into the curb return.

5.35.5 CUTOFF WALLS

At ford locations where roads are dipped to allow drainage flows to cross the roadway, cutoff walls shall be used to protect from erosion.

For uncurbed roadways locate the cutoff walls at the normal edge of shoulder location and extend the pavement across the shoulders to the cutoff walls.

For curbed roadways cutoff walls may be incorporated into other standard elements. Cutoff walls can be combined with ribbon curb, attached sidewalk, concrete scupper spillway, or other element by modifying a standard detail. Where sidewalks are located adjacent to cutoff walls, the Engineer shall include safety rail to meet ADA and Building Code requirements.

5.36 SIDEWALKS

5.36.1 GENERAL

Sidewalks shall be designed in accordance with the MAG Uniform Standard Specifications and Details for Public Works Construction as Supplemented by MCDOT. All newly constructed sidewalks shall comply with the accessible route requirements of the Americans with Disabilities Act (ADA).

Sidewalks shall be a minimum of 4 inches thick and 5 feet wide with a ¼ inch drop per foot slope toward the street. All concrete used for sidewalk shall be per MAG Type “A” 3000-psi. All sidewalks shall be placed on compacted MAG aggregate base course per the Public Works Engineering Design Standards and Drawings. If the existing right of way width and utility conflicts prohibit the required five-foot (5’) sidewalk width, a four (4’) may be permitted at the discretion of the City Engineer. Sidewalks shall be provided in all subdivisions. Lighting standards, utility poles, traffic control devices, fire hydrants, mailboxes and similar obstructions shall be located a minimum of 1 foot outside of the sidewalk area. In cases where such items cannot be located outside of the sidewalk area, the sidewalks may be located five feet behind the back-of-curb. The developer is responsible for providing landscaping between the curb and the sidewalk.

All shared-use paths shall be 10 feet wide and paved in asphalt. The structural cross-section shall be 2” AC over 4”ABC. Design of shared use paths shall follow the AASHTO “Guide for the Development of Bicycle Facilities”.

5.36.2 DETECTABLE WARNINGS

Detectable warnings are to be installed at locations that represent potential hazards for pedestrians with vision impairments such locations include walkways that cross roadways and commercial driveways. Detectable warnings shall be installed per ADA requirements, and as provided in the City of Sierra Vista’s standard construction details.

5.36.3 CURB RAMPS

Curb ramps are required at pedestrian road crossings and shall be constructed per ADA standards, See Table 6.1 for curb ramp return radius design information.

5.37 Miscellaneous Roadways

5.37.1 CUL-DE-SAC.

- A. Function. No cul-de-sac will be longer than 650 feet in length when measured from the center of the bulb or the turnaround to the center of the local, collector or arterial street which provides two directions of access.
- B. Right-of-Way. 110-foot diameter circle.
- C. Constructed Street Width
 - 1. Residential. 86-foot bulb pavement diameter. 34-foot pavement width in tangent sections.
 - 2. Commercial and Industrial. 106-foot bulb pavement diameter. 40-foot pavement width in tangent sections.
- D. Number of Moving Lanes. 2.
- E. Design Speed. 25 m.p.h.
- F. Parking. Allowed on both sides of the street.
- G. Horizontal Curves. The minimum radius shall be 260 feet with a maximum superelevation rate of eight percent. The combination of radius and superelevation shall be in accordance with AASHTO standards.
- H. Length of Tangent. Between horizontal and vertical reverse curves shall be a minimum of 100 feet.
- I. Street Grades
 - Maximum - 7%.
 - Minimum - 0.75%.
- J. Sidewalks. Sidewalks shall be located immediately behind the curb and 5 feet in width. Wherever possible, sidewalk connections shall be made from the bulb of the cul-de-sac to the next nearest adjoining local street.

5.37.2 ALLEY.

- A. Function. Provide secondary access to multi-family, commercial and industrial properties that also front a public street. Alleys may be required at the rear of multi-family, commercial and industrial developments. Alleys shall be discouraged.
- B. Access to Parking from an Alley. Any parking lot may use an abutting alley for direct access to parking spaces; provided that the full width of the alley is dedicated to the public and fully paved with two inches of asphaltic concrete over six inches of aggregate base course or four inches of Portland Cement concrete reinforced with #8, 6-inch by 6-inch wire mesh over a sub-base compacted to 95 percent density and property drained to prevent impoundment of surface water.
- C. Right-of-Way. 20 feet.
- D. Constructed Alley Width. 20 feet.
- E. Number of Moving Lanes. 2.
- F. Parking. None.
- G. Intersection Design. None.
- H. Horizontal Curves. 260-foot minimum radius without the approval of the City Engineer.
- I. Length of Tangent. Between horizontal and vertical reverse curves shall be a minimum of 100 feet.
- J. Vertical Curves. Vertical curves shall be designed at all grade changes where the difference between adjoining grades is one percent or more. The minimum length of the vertical curve shall be 100 feet plus 50 feet for each 1% algebraic difference in grade over 1%. Vertical curves in lengths of less than the minimum stated may be acceptable, providing standard design features

addressing public safety and drainage are not impaired, with the approval of the City Engineer.

K. Alley Grades

Maximum - 6%.

Minimum - 0.75%.

L. Private Streets and Private Alleys

General Design Standards and Provisions of Private Streets and Alleys. (All collectors or arterials must be public streets).

1. Private streets and alleys shall meet the minimum pavement cross-section and construction standards as stated in this document.
2. Private streets shall have a minimum constructed street width of 26 feet.
3. All private local streets shall be designed to prohibit their use by through public traffic.
4. Private streets shall be permitted only where a satisfactory means of providing for their control and maintenance is demonstrated. Generally, such control and maintenance shall be accomplished through undivided ownership of private streets by a Property Owner's Association to which all unit owners must belong, under the covenants, conditions and restrictions, Property Owners' Association article and by-laws.
5. The City of Sierra Vista shall not be responsible for maintenance, liability or enforcement of traffic control on private streets. Erection and maintenance of all traffic control and are the responsibility of the Property Owners' Association. All signs shall be provided by the developer, subdivider, and/or neighborhood association.
6. Installation and maintenance of street name signs are the responsibility of the property owners association. Such signs shall meet all applicable MUTCD and City requirements.
7. A sign shall be placed at the entrance of each private street giving notice that the street is a private street.
8. Private streets shall be named according to current City of Sierra Vista criteria.
9. If the owners in the future should request that the private streets be changed to public streets, the owners shall fully agree that, before acceptance of such streets by the City, the owners will bear full expense of reconstruction or any other action necessary to make the streets fully conform to the requirements applicable at that time for public streets, and be in new or recently maintained to new condition as accepted by the City Engineer, prior to dedication and acceptance. Finally, the owners shall agree that the right-of-way shall be dedicated to public use without compensation to the owners for the street improvements and owners' expense in making such streets conform to the requirements applicable at that time for public streets.

5.37.3 Half-Width Streets. Half-width streets shall be discouraged except when necessary to provide right-of-way required by the Traffic Circulation Plan, to complete a street pattern already begun, or to ensure reasonable development of the adjoining un-platted parcels. Where an existing half-width street abuts a tract, the remaining half street shall be platted within the tract. The subdivider shall plat and develop a street of sufficient pavement width to accommodate two-way traffic (26-foot minimum).

Chapter 6 Intersections

6.1. GENERAL CONTROLS

This Chapter 6 applies to the design of intersections between two or more roadways each within the public right-of-way of a governing jurisdiction and each of the intersecting roadways is maintained by the governing jurisdiction. Other public and private roads accessing the City road system are to be compliant with Chapter 7 and may also be required to comply with elements contained in this Chapter.

6.1.1 INTERSECTION ANGLE AND ALIGNMENTS

Streets intersecting an Arterial or Collector Street shall do so at a 90° angle. Local streets shall typically intersect at right angles but in no case less than 75° unless approved by the City. Local streets intersecting a Collector Street or Arterial street shall have a tangent section of center line at least 150 feet in length measured from the right-of-way line of the Major street, except that no such tangent is required when the local street curve has a center line radius greater than 600 feet. Street jogs and commercial driveway accesses with centerline offsets less than 125 feet shall be avoided except when the City determines that vehicle conflicts do not exist. Street intersections with more than four legs and Y-type intersections with legs meeting in acute angles shall be prohibited.

6.1.2 INTERSECTION SPACING

Signalized intersections are preferred to be spaced at half mile intervals on arterial streets, with quarter mile intervals as a minimum spacing. Non-signalized intersections are to be spaced at least 660 feet apart on arterial roads. Two adjacent 'tee' intersections are to be avoided. It is desirable to align the 'two' intersections to create a single 4-legged intersection. If alignment of two 'tee' intersections cannot be accomplished, adjacent 'tee' intersections are to be spaced a minimum distance of 660 feet between them, or if acceptable to the City the minimum storage and taper requirements for back to back left turn lanes based on future traffic volumes.

The minimum spacing for intersections along collector roads is a nominal 360 feet.

Intersections located along local residential streets shall have a minimum of 75 feet separating the rights of way of the two intersecting streets.

6.1.3 INTERSECTION LOCATION

Intersecting roads are to have relatively straight approaches such that the stopping and intersection sight distances are provided on all approaches to the intersection.

6.1.4 INTERSECTION LONGITUDINAL GRADES

The approach of an intersection shall have a relatively level area with a grade of not more than 3 percent and not less than 0.75 percent for a distance required to provide adequate site distance along both intersecting streets and across the corners of the intersection as defined by the City of Sierra Vista Development Code or AASHTO (American Association of State Highway and Transportation

Officials), whichever is the most restrictive.

When feasible the longitudinal grade through intersections should not exceed two percent. The purpose of this requirement is to keep the cross slope of pedestrian crosswalk areas compliant with the ADA standard of a maximum two percent cross slope for pedestrian access routes.

6.1.5 INTERSECTION CROSS SLOPE

The cross slope may vary from 0.005 to 0.03 foot per foot for intersection transition areas.

The design control at the crossover crown line of two adjacent pavements is the algebraic difference in the cross-slope rates. Where both pavements slope down and away from the crossover crown line, the algebraic difference is the sum of their cross slope rates, where they slope in the

same direction, it is the difference of their cross-slope rates. The maximum algebraic difference at a crossover crown line shall not exceed 4.0%.

Signal installation is likely to occur at arterial-to-arterial intersections and at arterial to major collector intersections. At intersections where signal installation is likely to occur, the vertical design of the through travel lanes of the road having the highest design speed with the highest classification is to comply with the geometric requirements of Section 5.11. Where signal installation is likely to occur, the maximum crown break-over angle for asphalt pavement shall not exceed 1.5 percent. Reducing roadway cross slopes to 0.005 foot per foot through intersections will provide an acceptable break-over angle for asphalt roadways since the asphalt material will not form a sharp break-over angle. For intersections constructed with Portland cement concrete pavement a sharp break-over crown line is to be avoided by providing spot elevations that approximate a parabolic curve.

The maximum grade break on a stop sign controlled residential or minor collector street at a valley gutter shall be 8.0%.

6.1.6 INTERSECTION LANE REQUIREMENTS

A traffic analysis is required to determine the number of lanes and the lane configuration for intersections. The desired level of service is dependent on roadway classifications; the minimum desired LOS is D.

Developments are to construct auxiliary lanes when the following thresholds are expected to be met due to the addition of the projected development traffic.

A. Right Turn Lane is to be provided when:

1. The roadway has 2 approach through lanes, a posted speed limit of 45 mph or greater, and an expected right-turn peak hour volume of 300 vph or greater.
2. The roadway has 1 approach through lane, a posted speed limit of 35 mph or greater, and an expected right-turn peak hour volume of 300 vph or greater.
3. On any roadway where a traffic impact analysis indicates the LOS would be increased to a LOS of D or better with the addition of a right-turn lane.
4. In rural and developing urban areas with higher speeds, a separate right turn lane may be required for lower right turn volumes.

B. Left Turn Lane is to be provided:

1. At all signalized intersections
2. When the left turn movement into another roadway results in a LOS less than the minimum LOS of D during any peak hour.

C. Dual Left-Turn Lanes are to be provided when:

1. The peak hour left-turn volume exceeds 300 vehicles per hour.
2. The peak hour conflicting through movement volume exceeds 1,000 vehicles per hour.
3. A traffic impact analysis indicates the LOS would be increased to a LOS of D or better with the addition of dual left turns.

The threshold volumes used to determine the need for turn lanes are based on a normal mix of design vehicle types, the volume limits may be adjusted at the discretion of the City Engineer.

In some circumstances, left turn lanes may not be required at signalized intersections; those intersections will generally require split phase signal operation and will be evaluated by The City on a case-by-case basis.

6.1.7 INTERSECTION TURN LANE DESIGN

Intersections are to be designed to allow the passenger car (P) design vehicles approaching from opposite directions to turn left simultaneously without conflict with each other. At arterial-arterial intersections two WB-50 design vehicles approaching from opposite directions are to be able to turn left simultaneously without conflict.

The design of signalized intersections shall provide sufficient turning space to accommodate design vehicle off tracking for both right and left turns on all approaches. The design vehicle for signalized intersection design is as defined in Section 4.1.2 DESIGN VEHICLE. Design vehicle off tracking shall not cause any part of the design vehicle to encroach into an opposing traffic lane, opposing left turn lane, or extend beyond the face of any curb or any pavement edge. Widening of the receiving lane or lanes is to be provided as needed to accommodate the design vehicles off tracking turning movements. Receiving lane widening (throat widening) can be accomplished using an asymmetric three centered curve or an offset curve with a closing taper section.

At intersections with dual left turn lanes three receiving lanes on the exit portion of the intersection are usually needed to accommodate truck turning movements. The outside left turn lane and the two exterior receiving lanes on the exit portion of the intersection are used to accommodate the truck turning path of a WB-50 design vehicle. When only two receiving lanes are available then the exterior lane shall have sufficient throat widening to allow the design vehicle to turn without encroaching onto the interior receiving lane or exterior curb.

Right turns onto an arterial roadway by the WB-50 design vehicle shall not encroach into the opposing traffic or left turn lane. Lane widening shall be provided as needed to accommodate the truck turning movement.

The design vehicle's turning template is to be used to ensure sufficient width is provided to accommodate off tracking turning movements. Receiving lane widening (throat widening) shall be provided as needed to accommodate the off tracking turning movements.

For arterial and collector roads the storage length for auxiliary turn lanes is to be determined by a
2023 Update

traffic analysis for both signalized and unsignalized intersections. The minimum storage for both collectors and arterials is generally the same due to the possibility of collector roadways becoming signalized at a future date. The storage criteria shown below will apply to both urban and rural conditions.

Exception to the minimum turn lane storage requirements shown below may be granted by the City Engineer.

6.1.8 LEFT TURN LANE STORAGE

For arterials and collector roads, the minimum storage length is 160 feet. This will apply to both signalized and unsignalized intersections. For local roads the minimum storage length is 75 feet.

6.1.9 RIGHT TURN LANE STORAGE

For arterials and collector roads, the minimum storage length is 160 feet. This will apply to both signalized and unsignalized intersections.

6.1.10 AUXILIARY LANE TRANSITION TAPERS

Opening tapers for auxiliary turn lanes without curbing are to be added with an opening taper rate of 8:1 (L:W) minimum and 15:1 (L:W) maximum. Use an 8:1 opening taper for design speeds of 30 mph or less and a 15:1 opening taper for design speeds of 50 mph or greater.

For auxiliary lanes with curbing provide reverse curves as illustrated in Fig. 6.1.

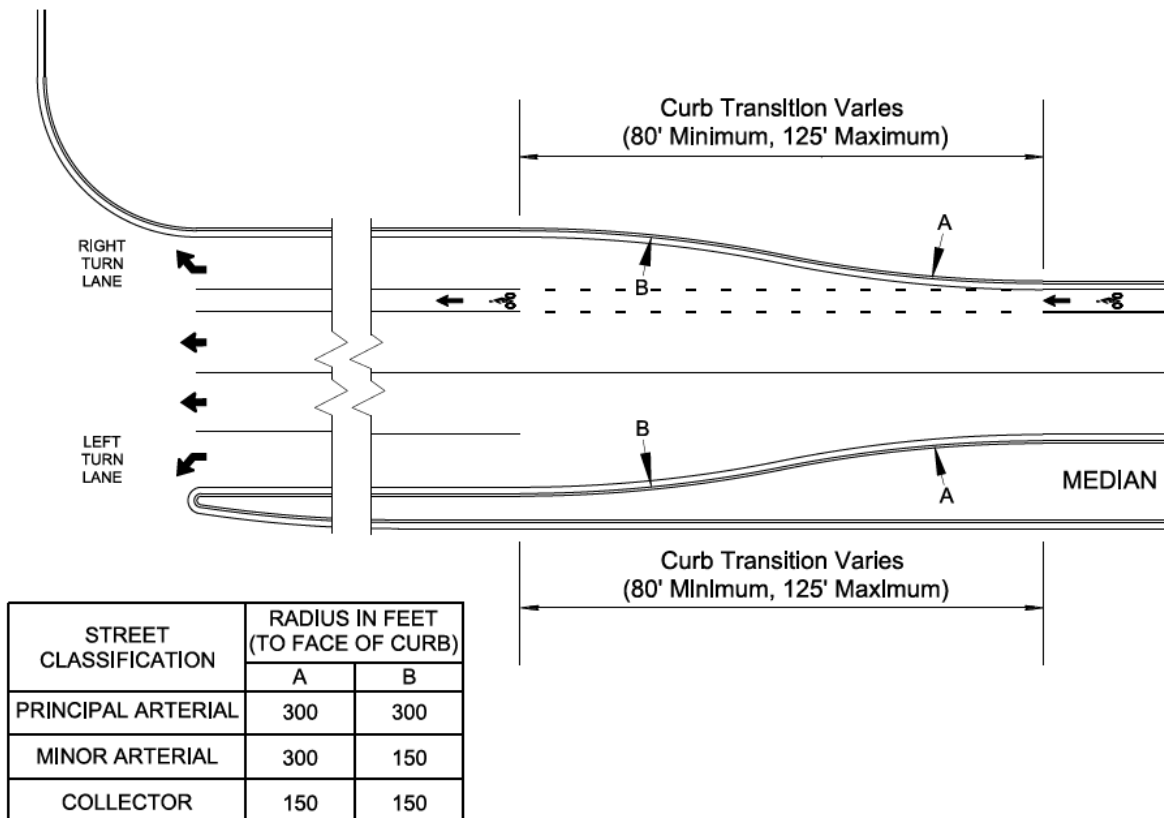

Figure 6. 1: AUXILIARY TURN LANES – CURB TRANSITIONS

6.1.11 LAYOUT REQUIREMENTS FOR AUXILIARY TURN LANES

Figure 6.2 shows a left turn auxiliary lane layout for a rural principal arterial.

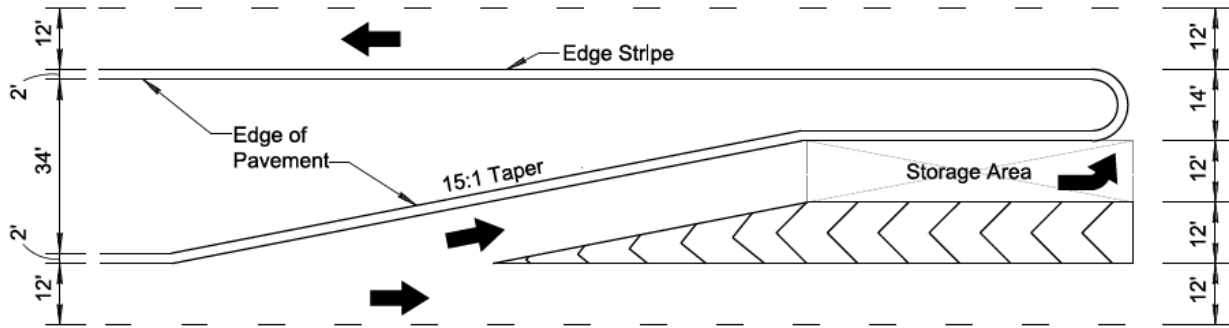

Figure 6. 2LEFT-TURN LANE LAYOUT FOR RURAL PRINCIPAL ARTERIAL

FIGURE 6.2: LEFT-TURN LANE LAYOUT FOR RURAL PRINCIPAL ARTERIAL

Figures 6.3(A) and 6.3(B) illustrate potential methods for adding a left turn lane to a two lane roadway. Note that the offset distance for symmetrical widening is half the distance as required for widening on one side only, therefore the taper length for symmetrical widening is half the length required for widening on one side only.

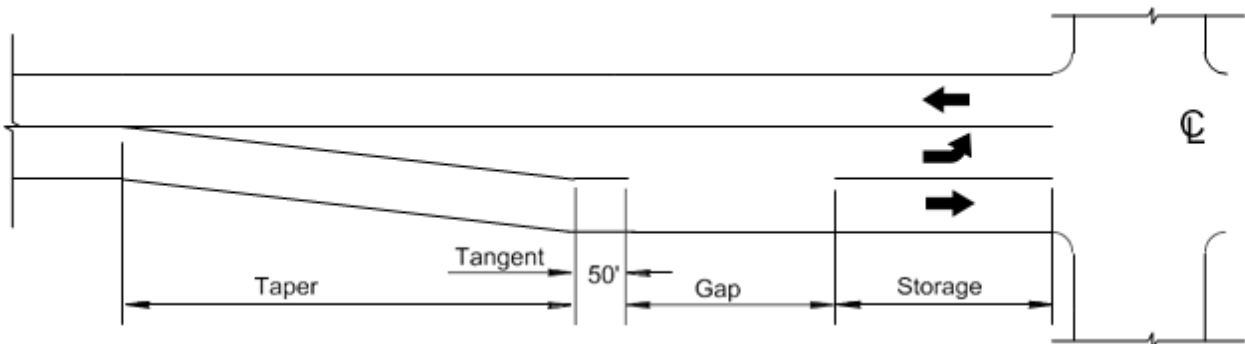

Figure 6. 3(A):LEFT-TURN LANE – WIDENING ONE SIDE ONLY

FIGURE 6.3(A): LEFT-TURN LANE – WIDENING ONE SIDE ONLY

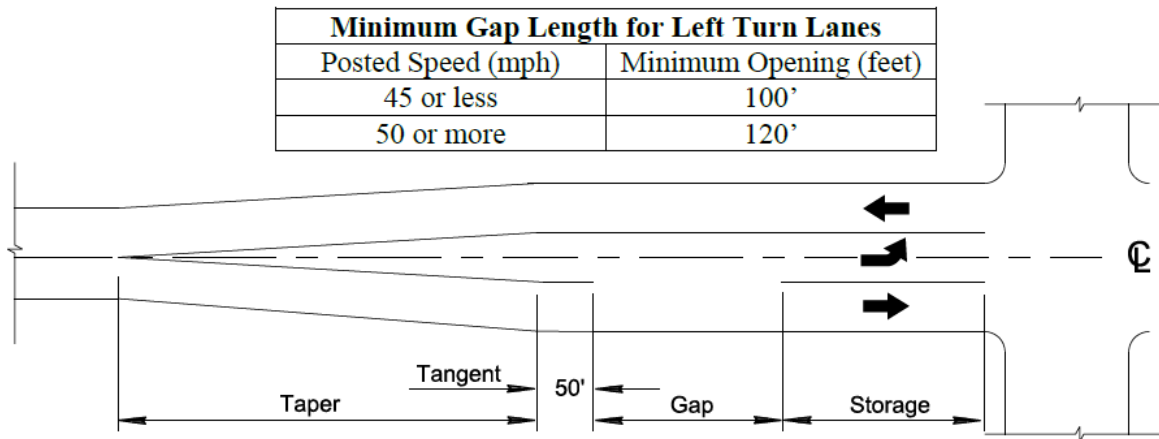

Figure 6.3(B) LEFT-TURN LANE – SYMMETRICAL WIDENING

FIGURE 6.3(B): LEFT-TURN LANE – SYMMETRICAL WIDENING

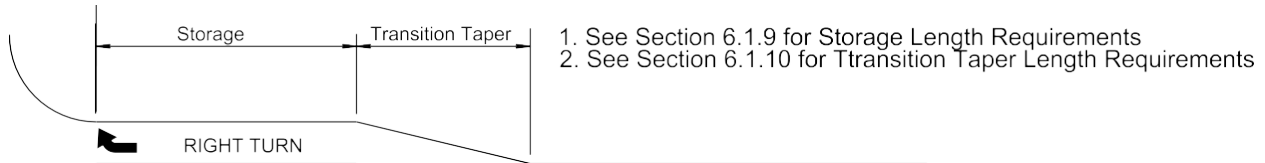

Figure 6.3(C): RIGHT-TURN LANE LAYOUT

6.1.12 INTERSECTION RETURNS

The radii for returns at intersections shall be measured to the face of the curb or if no curb to the edge of pavement. The minimum radii shall be in accordance with Table 6.1. The return radius point may need to be offset from the adjacent roadway curb lines to provide throat widening of the receiving lanes to accommodate design vehicle off tracking.

TABLE 6.1: RETURN RADIUS		
TYPE OF ROAD	RETURN RADIUS* WITH CURB AND GUTTER (FT.)	RETURN RADIUS* WITHOUT CURB AND GUTTER (FT.)
Arterial With Arterial	35	45
Arterial With Major Collector	35	45
Arterial With Minor Collector	30	45
Arterial With Residential	30	35
Major Collector With Major Collector	30	35
Major Collector With Minor Collector	30	30
Major Collector With Residential	30	30
Minor Collector With Minor Collector	30	30
Minor Collector With Residential	25	30
Residential With Residential	25	25
* Return radii for roadways serving industrial and commercial developments shall not use a radius less than 30-feet; use of three centered curves is preferred.		

Return radii for parkways shall be the same as required for arterial roadways, except where turning movements are not allowed.

6.1.13 INTERSECTION SIGHT DISTANCE

Where left turning traffic must yield to on-coming traffic, provide a minimum of 3.5 feet of positive offset for opposing left-turn lanes to ensure adequate sight distance for left-turning drivers.

Clear sight triangles shall be provided at all intersections. The type of sight triangle (approach or departure) will depend on the type of intersection control provided. The dimensions of the sight triangles are to be determined in compliance with the procedures identified in the AASHTO publication *A Policy on Geometric Design of Highways and Streets*.

Departure sight triangles shall be calculated using the vehicle type shown in Table 6.2 and the decision point (vertex of the clear sight triangle) shall be located eighteen foot (18.0') back from the near edge of arterial roads and fourteen and a half feet (14.5') from the near edge of collector and local roads. Departure clear sight triangles shall be contained within the road right-of-way to ensure sight obstructions are not placed within the sight triangles.

TABLE 6.2: VEHICLE TYPE FOR DETERMINING DEPARTURE SIGHT TRIANGLES				
Major Road Classification	Minor Road Classification	Vehicle 1		
		Right Turn	Left Turn	Cross
Arterial	Arterial	Combination Truck	Combination Truck	Single Unit Truck
Arterial	Collector	Single Unit Truck	Single Unit Truck	Single Unit Truck
Arterial	Local	Single Unit Truck	Single Unit Truck	Single Unit Truck
Collector	Collector	Single Unit Truck	Single Unit Truck	Single Unit Truck
Collector	Local	Single Unit Truck	Single Unit Truck	Single Unit Truck
Local	Local	Single Unit Truck	Single Unit Truck	Single Unit Truck
Residential Subdivision Local	Residential Subdivision Local	Passenger Car	Passenger Car	Passenger Car

6.1.14 RIGHT-OF-WAY REQUIREMENTS

Right-of-way at intersections shall include all areas within the intersection departure sight triangles. A Sight Visibility Easement in lieu of right-of-way may be provided for areas where the departure sight triangle extends beyond the corner lot. The Sight Visibility Easement is to restrict plantings and construction that may obstruct visibility and require the property owner to maintain unobstructed sight visibility within the departure sight triangle.

Where the standard roadway width is increased for auxiliary lanes or bus stops, the right-of-way shall be increased to accommodate sidewalk at the standard offset distance behind the widened roadway curb line plus a minimum of 2.5 feet between the back of sidewalk and the right-of-way line.

6.2 ROUNDABOUTS

6.2.1 GENERAL

A modern roundabout is a type of circular intersection characterized by channelized approaches, yield control at entry, counterclockwise circulation around a central island, and geometric features that create a low-speed environment. Roundabouts offer safety, operational, and other advantages over conventional intersections including fewer conflict points, lower speeds, improved traffic flow, lower fuel consumption, and reduced air pollution.

All roundabout designs are to comply with Transportation Research Board (TRB) National Cooperative Highway Research Program (NCHRP) Report 672 *Roundabouts: An Informational Guide, Second Edition* produced in cooperation with the U.S. Department of Transportation, Federal Highway Administration (FHWA).

Figure 6.4 identifies various design features of the modern roundabout.

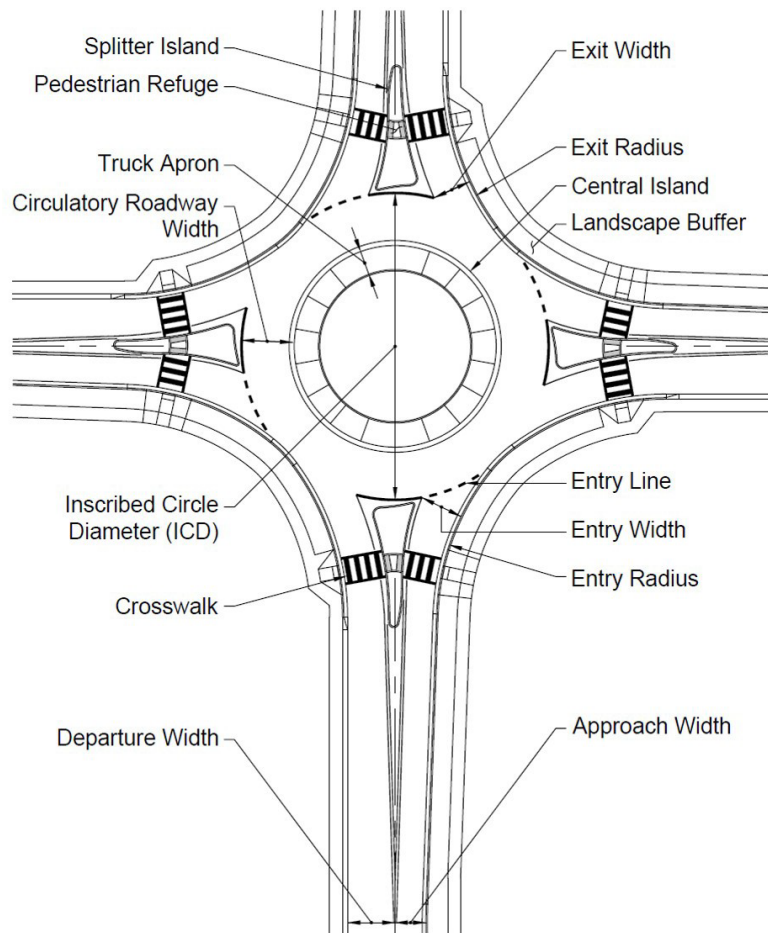

Figure 6. 4: GEOMETRIC ELEMENTS OF A ROUNDABOUT

6.2.2 APPLICABILITY

- A. Roundabouts may provide beneficial advantages over a conventional intersection for any of the following conditions:
 1. Where stop controls (stop signs or signals) are causing unnecessary delay.
 2. Where there is a high left turn percentage on one or more legs.
 3. Where there have been a disproportionately high number of head on or right-angle collisions.
 4. Where it is not desirable to give priority to either street; and
 5. Where there is unusual intersection geometry.

- B. Certain physical or geometric complications may make it uneconomical or ineffective to construct a roundabout at the location being evaluated. These could include right of way limitations, utility conflicts, drainage problems, and proximity of significant traffic generators or traffic control devices requiring pre-emption, as needed at railroad crossings. Specific conditions in which the use of roundabouts will be unacceptable include the following:
 1. Where roadway grade exceeds 4%;
 2. Where there is inadequate sight distance;
 3. Where major roadway ADT exceeds 90% of total intersection ADT;
 4. Where high volumes of pedestrians with special needs would have difficulty crossing the road.
 5. Where a downstream traffic control device such as a traffic signal would result in a queue that extends into the functional area of the roundabout
 6. At a single intersection within coordinated signal network.

6.2.3 DESIGN PROCESS

The design process for roundabouts is usually an iterative process of evaluating the geometric layout for operational performance, and safety. Minor adjustments in geometry can result in significant changes in the safety and/or operational performance. Thus, the designer often needs to revise and refine the initial layout attempt to enhance its capacity and safety. NCHRP Report 672 Exhibit 6-1 provides a general outline for the design process with cross-references to other sections of the Report for each individual step within the process.

6.2.4 GENERAL DESIGN CRITERIA

Table 6.3 identifies criteria to be used for roundabout design based on the classification of the approach roadways.

TABLE 6.3: ROUNDABOUTS – GENERAL DESIGN REQUIREMENTS			
Feature/Parameter	Mini-Roundabout	Single-Lane Roundabout	Multilane Roundabout⁽¹⁾
Approach Roadway Classifications	Minor Collector Local Residential	Major Collector Minor Collector Local Residential	Principal Arterial Minor Arterial Major Collector Minor Collector
Maximum Entry Speed and Maximum Circulating Speed	20 mph	25 mph	30 mph

Sierra Vista Modified Maricopa County Roadway Design Manual

Typical Inscribed Circle Diameter (ICD)	90 feet	110-150 feet	140-200 feet
Design Vehicle (Exterior Circulating Lane(s))	S-BUS-40	BUS-40 ⁽⁴⁾	WB-50 ⁽²⁾
Design Vehicle (Interior Circulating Lane + Truck Apron)	Not Applicable	WB-50	WB-62 ⁽³⁾
Design Vehicle (Circulating Lane + Central Island)	WB-50	Not Applicable	
<p>(1) Values provided are for two-lane configurations.</p> <p>(2) Exterior circulating lanes are to be designed to accommodate in-lane all through movements of WB-50 vehicles. Exterior circulating lanes connecting arterial-to-arterial roadways are to be designed to accommodate in-lane through movements of WB-67 vehicles.</p> <p>(3) WB-62 and WB-67 vehicles may use the interior circulating lane with the adjacent truck apron for through and turning movements. WB-50 vehicles may use the interior circulating lane with the adjacent truck apron for turning movements, through movements are to be accommodated in-lane. The BUS-40 vehicle shall not use the truck apron.</p> <p>(4) The S-BUS-40 design vehicle may be used as the design vehicle for Single-Lane roundabouts connecting only Local Residential and Minor Collector roads.</p>			

Figures 6.5 and 6.6 are geometric layout examples for a single lane roundabout and a multilane roundabout. The right-of-way shown is the minimum required for construction of the roadway and pedestrian facilities. Additional right-of-way area or an easement is needed to protect sight lines

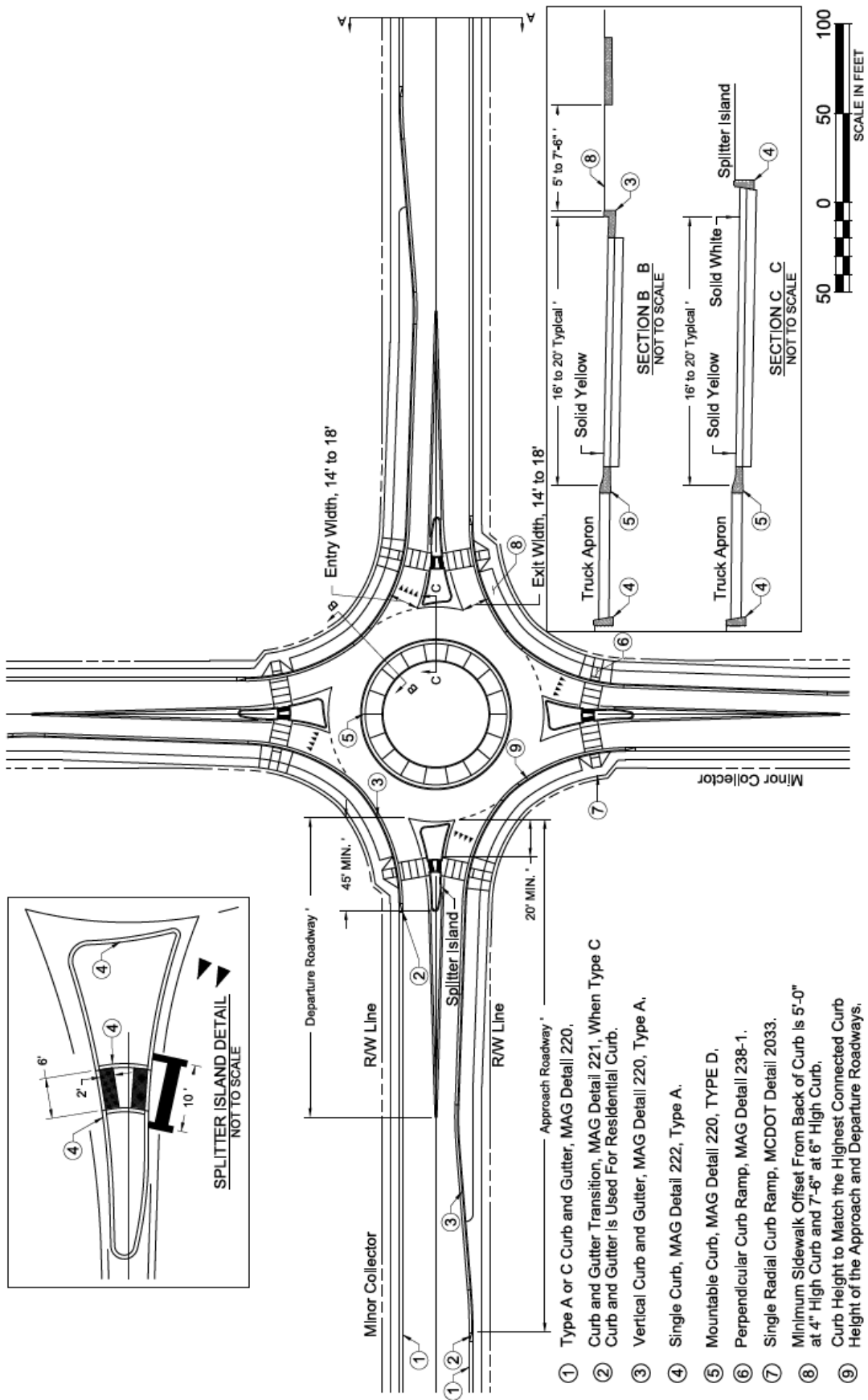

Figure 6. 5: URBAN SINGLE-LANE ROUNDABOUT

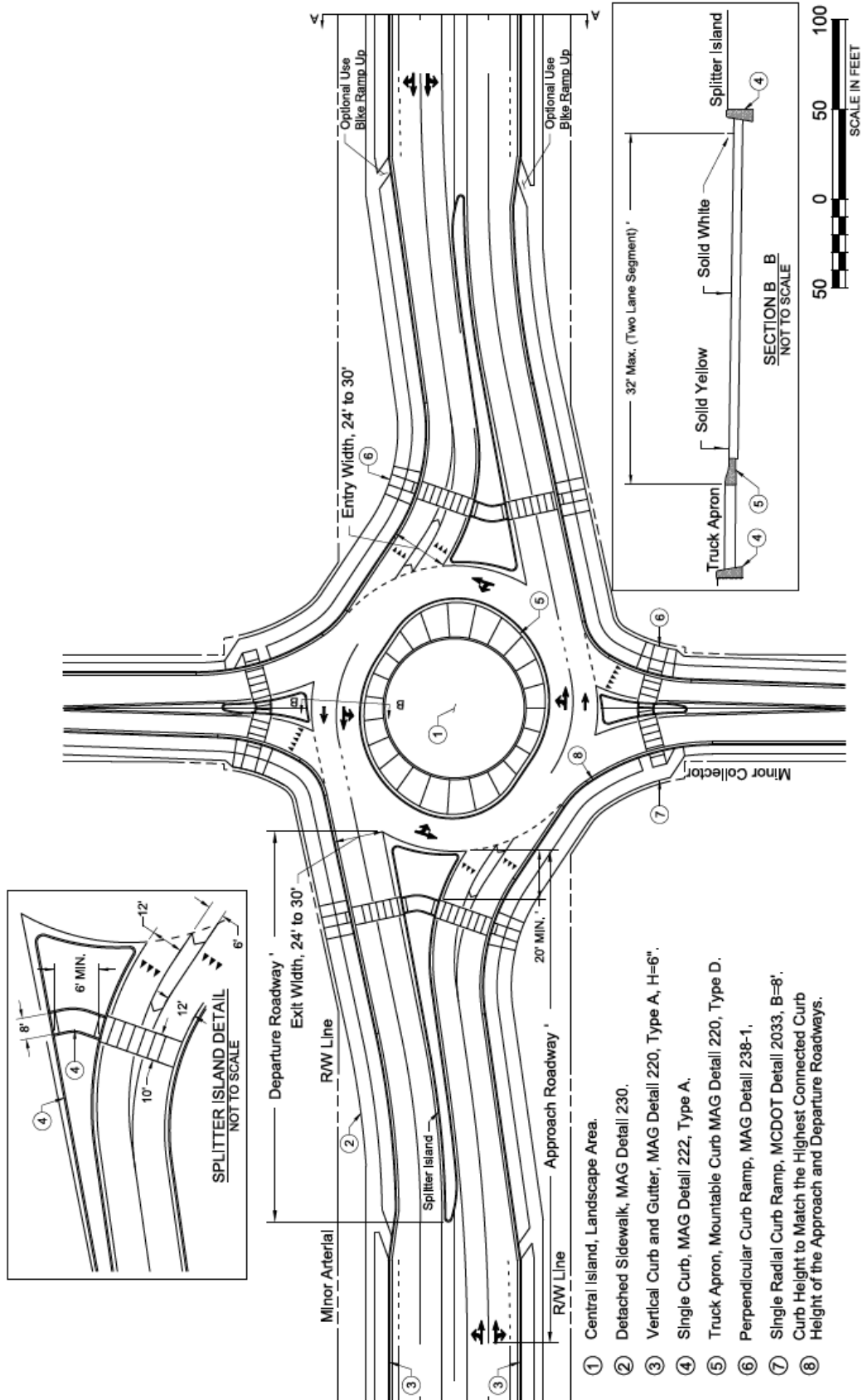

Figure 6. 6: URBAN MULTILANE ROUNDABOUT

6.2.5 SUBMITTAL REQUIREMENTS SUMMARY

- A. In addition to plan review requirements specified elsewhere in this Manual, all roundabout design submittals shall include the following supporting documentation:
1. Capacity analysis documentation as further specified in Section 6.2.6
 2. Design vehicle tracking documentation as further specified in Section 6.2.10
 3. Fastest Path documentation as further specified in Section 6.2.10
 4. Sight distance documentation as further specified in Section 6.2.10

6.2.6 VALIDATING LANE NUMBERS AND ARRANGEMENTS

The number of entering, circulating, and exiting lanes at roundabouts has a pronounced effect on roundabout operation. In general, it is desirable to provide only enough lanes necessary to provide acceptable capacity. Fewer lanes provide less complex operation, which generally translates into improved safety. The number and assignment of approach lanes is to be determined for each approach in accordance with the guidelines and procedures outlined in the Roundabouts chapter of the most current edition of the Highway Capacity Manual (HCM).

All roundabout designs must be supported by a documented roundabout capacity analysis demonstrating adequacy of the proposed number and arrangement of lanes to accommodate design year design hour traffic volumes consistent with the requirements stated in Section 2.2 of this Manual. Adequacy is to be confirmed for both AM and PM peak hours for both the opening year and design year. The scope of the required analysis is at the discretion of the City Engineer and will depend on the type of roundabout being proposed (mini-, single-lane or multilane), the context within which the roundabout is being proposed (new construction or retrofit), and the proximity of the proposed roundabout to existing and planned future adjacent intersections, driveways and other features with which the roundabout's design must be coordinated.

At a minimum, analysis documentation shall include input parameter values represented graphically as generally depicted Figure 6.7, along with a reporting of volume-to-capacity ratio, control delay, level of service and 95th percentile queue for each approach, under opening year conditions and design year conditions, respectively. If the roundabout will open with lane geometry that is different from what is needed to accommodate design year conditions, the expected life of the interim lane geometry is to be indicated, as is the way transition between interim and ultimate geometry will be accomplished. For those roundabouts proposed for locations that will be located less than a half mile from a signalized intersection, an at-grade railroad crossing and/or another roundabout, additional analysis which considers the effects of upstream and downstream traffic control may be required at the discretion of the City Engineer. Similarly, for those roundabouts proposed to replace existing traffic control (retrofit applications) additional analysis justifying the conversion of traffic control/configuration from conventional intersection to a roundabout may be required at the discretion of the City Engineer.

Sierra Vista Modified Maricopa County Roadway Design Manual

Traffic Flow Diagram

Intersection		Analysis Year	
Project No.	Prepared By	Date Prepared	

AM Peak Hour Volumes

Peak Hour Factor _____

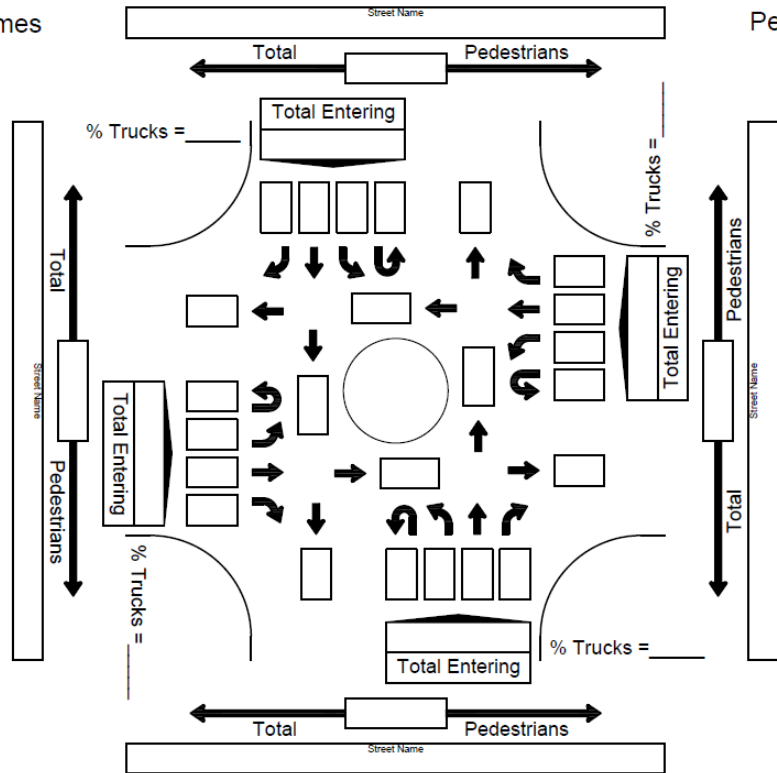

PM Peak Hour Volumes

Peak Hour Factor _____

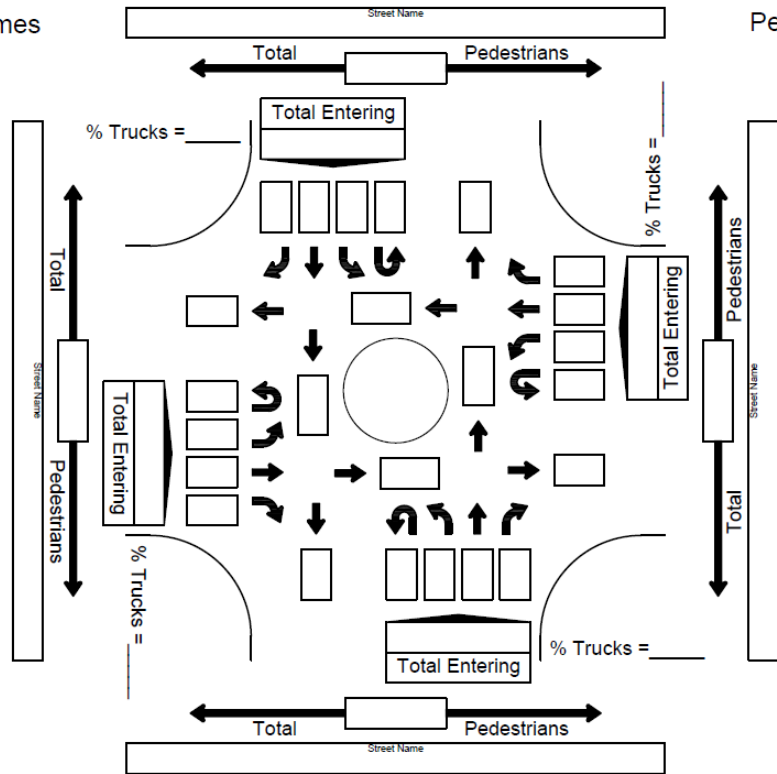

Figure 6.7: Traffic Volume and Lane Configuration Diagram

6.2.7 BASIC DESIGN PRINCIPLES

A. Fundamentally, the principles of roundabout design are the same as for other types of intersections. The designer must consider the context of the project and provide suitable geometry and traffic control devices, per established engineering principles. The following principles govern all roundabout designs:

1. Cause slow entry speeds and consistent speeds through the roundabout by using deflection.
2. Provide the appropriate number, type, and arrangement of lanes to achieve adequate capacity, lane volume balance, and lane continuity.
3. Provide smooth channelization that is intuitive to drivers and results in vehicles naturally using the intended lanes.
4. Provide adequate accommodation for design vehicles. The swept path for design vehicles is not to encroach onto an adjacent travel lane.
5. Provide appropriate sight distance and visibility for driver recognition of the intersection and conflicting users.
6. Design to meet the needs of pedestrians and cyclists.

6.2.8 GEOMETRIC DESIGN ELEMENTS

A. INSCRIBED CIRCLE DIAMETER (ICD)

Have the inscribed circle diameter be the minimum required to accommodate the design vehicle, the desired number of lanes, the maximum desired entry speed, and the maximum desired circulating speed. For a WB-50 design vehicle the minimum inscribed circle diameter for a single-lane roundabout should be 110 feet. Additional guidance on ICD dimensioning is provided in Table 6.3.

B. APPROACH ALIGNMENT

The most critical roundabout design objective is to cause low and consistent speeds into and through the roundabout. This condition is created primarily by curb geometry which causes deflection and should begin on the approach to the yield line. Refer to NCHRP Report 672 Section 6.3.2 for a detailed discussion on the role approach alignment plays in the design of a roundabout and the advantages and disadvantages of various approach alignment alternatives.

C. SPLITTER ISLANDS

Splitter islands are to be designed to control vehicle speeds through path deflection, prevent exiting traffic from accidentally crossing into the path of approaching traffic, reinforce one-way circulation, and provide (with the possible exception of mini-roundabouts) a pedestrian refuge area. The pedestrian cross through refuge area shall be six feet (6') wide. When the width of a curb ramp accessing the splitter island exceeds six feet, the width of the refuge area shall be increased to match the width of the curb ramp. Figure 6.8 provides additional guidance in the sizing and positioning/orientation of critical splitter island design elements.

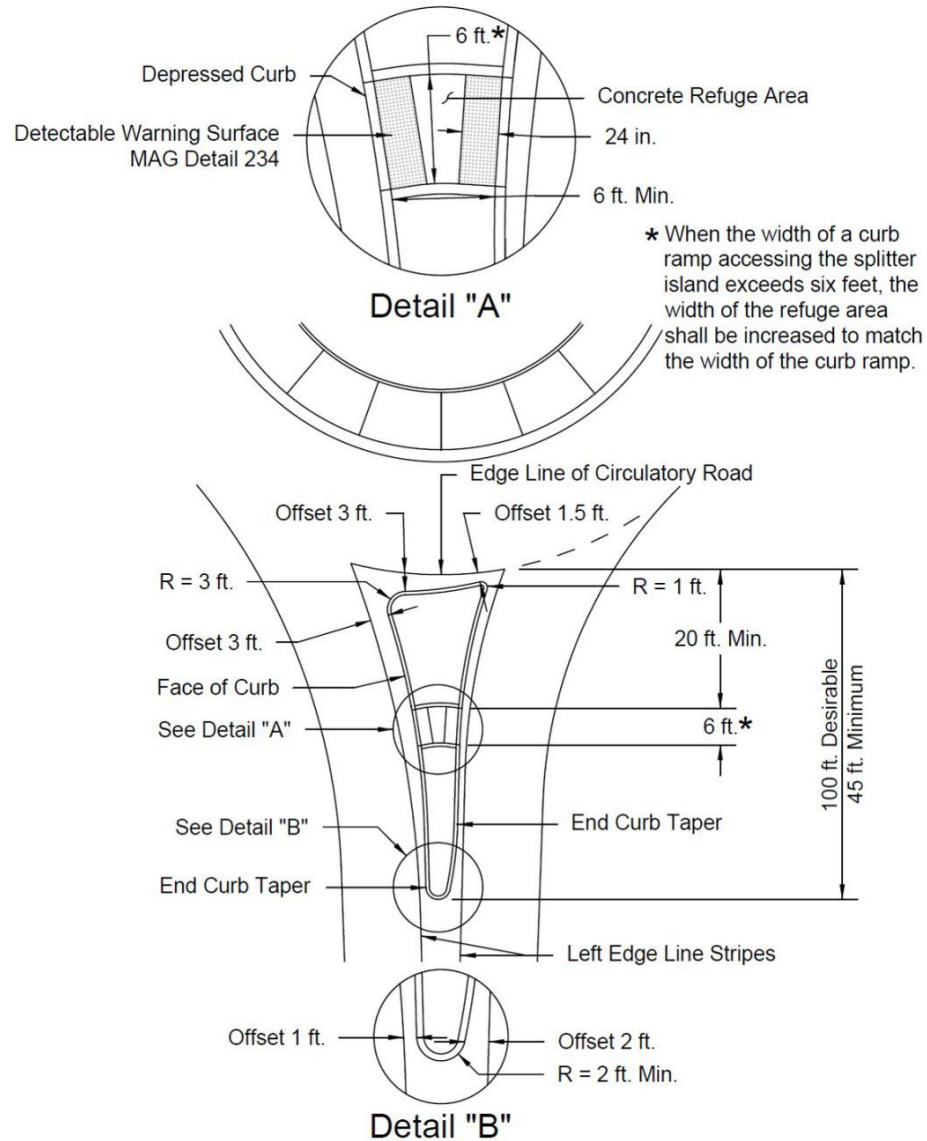

Figure 6.8 SPLITTER ISLAND CURB OFFSETS

D. ENTRY WIDTH

The entry width is measured from the point where the yield line intersects the left edge of the traveled way to the right edge of the traveled way, along a line perpendicular to the right curb line. Entry width should be kept to a minimum to maximize the safety of the roundabout and wide enough to accommodate the largest design vehicle. Typical entry widths range from 14-18 feet for single-lane entrances and 28-32 feet for two-lane entrances.

E. CIRCULATORY ROADWAY WIDTH

The width of the circulatory roadway should be at least as wide as the maximum entry width, no more than 1.2 times the entry width, and remain constant throughout the roundabout. Appropriate vehicle templates shall be used to determine the roadway circulatory width. A minimum of 2 feet is to be provided between the circulating lane design vehicles' wheel paths and circulatory road curb lines. A minimum of 3 feet is to be provided between the inner truck apron curb and the

wheel path of the design vehicle for truck apron use. Figure 6.9 illustrates how these clearance dimensions are to be measured.

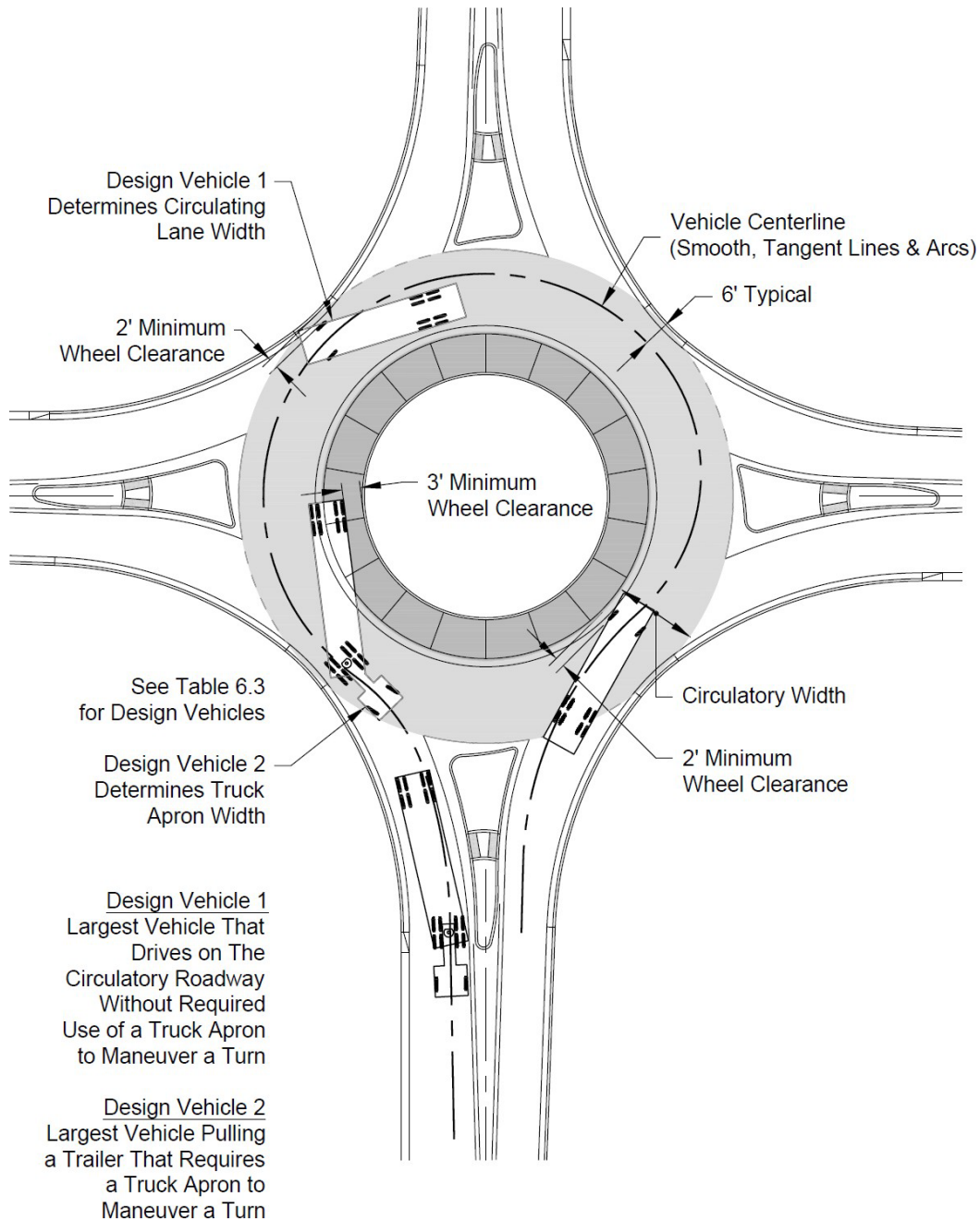

Figure 6.9: Design Vehicle Curb Clearances

F. CENTRAL ISLAND

The central island of a roundabout is the raised, mainly non-traversable area surrounded by the circulatory roadway. It may also include a traversable truck apron. The central island shall not contain anything that attracts pedestrians onto the island or that can be a distraction to drivers. Central islands shall be visible to approaching traffic and provide a cue for traffic to slow down and carefully navigate the intersection.

G. ENTRY RADIUS

The entry radius is to be designed curvilinearly tangential to the outside edge of the circulatory roadway. The projection of the left edge of each entry roadway lane is to be curvilinearly tangential to the left lane line of the receiving lane of the circulatory roadway, which may be the central island. A short tangential section or gore area approaching the yield line may be needed to prevent overlapping paths. With multilane roundabouts, the designer is to consider the natural paths of vehicles to ensure the proposed geometry directs vehicles to stay within the proper lanes through the circulatory roadway and exits. Path overlap occurs when the natural paths of vehicles in adjacent lanes overlap or cross one another. The entry design should align vehicles into the appropriate lane within the circulatory roadway, using the technique shown in Figure 6.10 or others that promote good path alignment. See NCHRP Report 672 Section 6.4.5 for additional guidance on entry design for single-lane roundabouts and Section 6.5.4 for guidance on entry design for multi-lane roundabouts, including avoiding Entry Path Overlap.

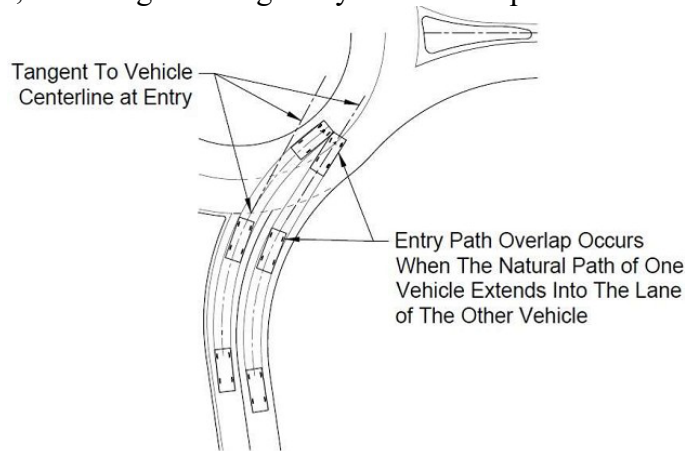

ENTRY ALIGNMENT WITH PATH OVERLAP
(Unacceptable)

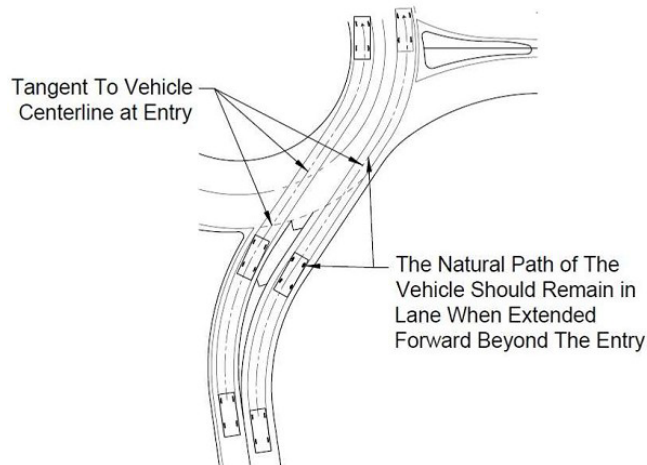

ENTRY ALIGNMENT WITHOUT PATH OVERLAP
(Acceptable Entry Alignment)

Figure 6.10 ENTRY PATH ALIGNMENT - AVOID PATH OVERLAP

H. EXIT RADIUS

The exit curb radius is to be curvilinearly tangential to the outside edge of the circulatory roadway. Guidance on exit design is provided in NCHRP Report 672 Sections 6.4.6 and 6.5.6.

I. TRUCK APRON

Truck aprons are traversable areas provided to accommodate semi-trailer off-tracking while keeping the circulatory roadway width narrow enough to maintain speed control for smaller vehicles.

Truck aprons shall be a different color and texture than the roadway surface. Truck aprons shall be raised above the adjoining roadway using roll curb.

Where truck aprons are used, the slope of the apron shall not exceed two percent.

6.2.9 MINI-ROUNABOUTS

A mini roundabout is a type of roundabout characterized by a relatively small inscribed circle diameter, fully traversable central island, and splitter islands.

Figures 6-11 and 6-12 illustrate a typical mini-roundabout layout connecting two intersecting local residential streets. Figure 6-11 identifies features and typical standard construction details to be used for mini-roundabout designs and Figure 6-12 demonstrates the magnitude of dimensions that may occur within in a typical geometric layout.

The location and size of a mini-roundabout central island (and the corresponding width of the circulatory roadway) is usually determined by the S-BUS-40 swept path requirements. The off-tracking of vehicles larger than an S-BUS-40 is accommodated by vehicles encroaching onto the footprint of the central island.

Mini roundabouts differ from neighborhood traffic (calming) circles by having approach splitter islands on all approaches and a traversable central island. Neighborhood traffic circles may be used to create a low-speed environment within residential subdivisions if they will have the same functional characteristics as a roundabout. The approaches must naturally cause counterclockwise circulation around the central island, have yield control at all entries, and accommodate passage of a WB-50 design vehicle.

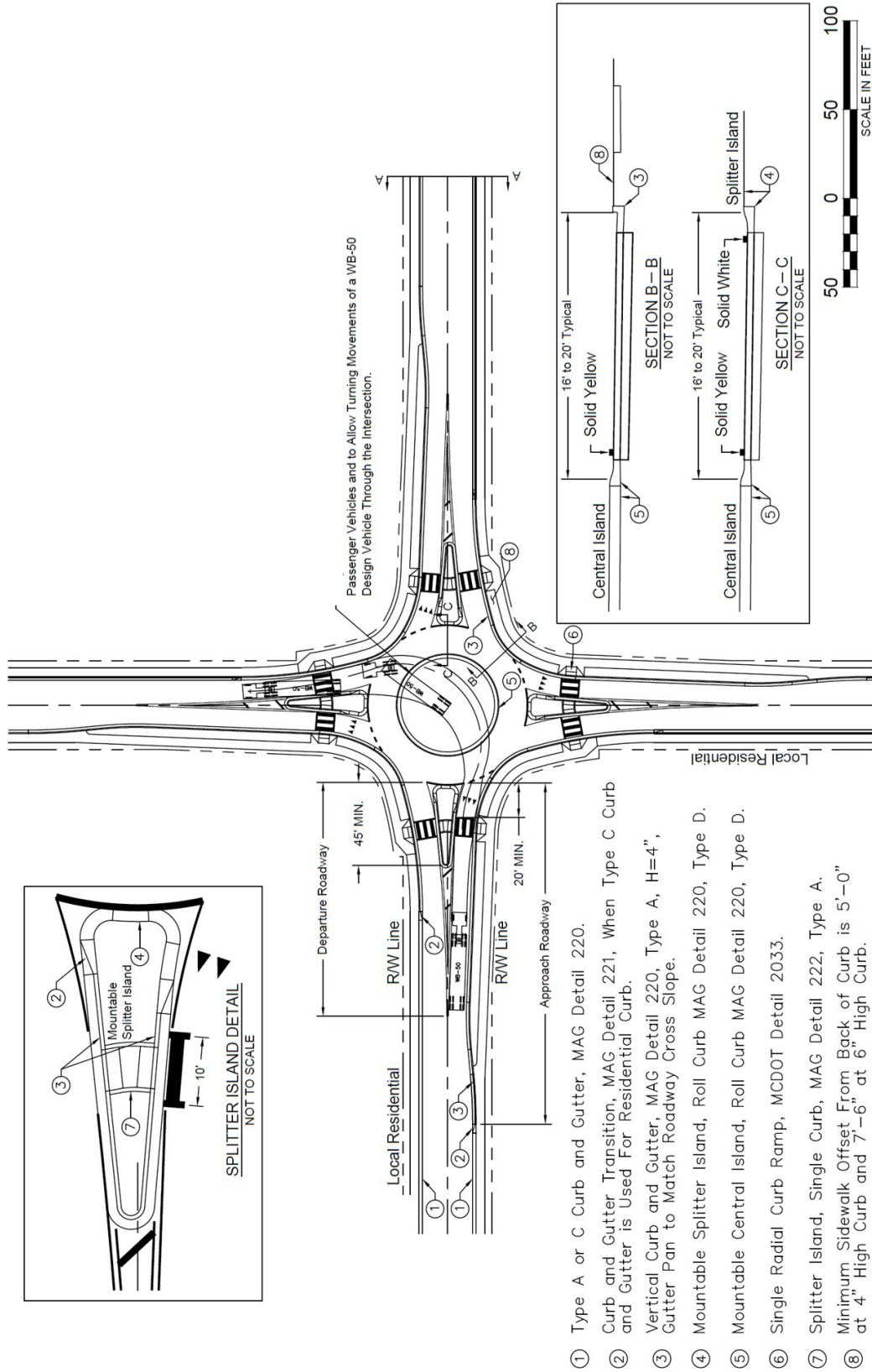

Figure 6.11 URBAN MINI-ROUNABOUT TYPICAL LAYOUT

- ① Type A or C Curb and Gutter, MAG Detail 220.
- ② Curb and Gutter Transition, MAG Detail 221, When Type C Curb and Gutter is Used For Residential Curb.
- ③ Vertical Curb and Gutter, MAG Detail 220, Type A, H=4", Gutter Pan to Match Roadway Cross Slope.
- ④ Mountable Splitter Island, Roll Curb MAG Detail 220, Type D.
- ⑤ Mountable Central Island, Roll Curb MAG Detail 220, Type D.
- ⑥ Single Radial Curb Ramp, MCDOT Detail 2033.
- ⑦ Splitter Island, Single Curb, MAG Detail 222, Type A.
- ⑧ Minimum Sidewalk Offset From Back of Curb is 5'-0" at 4" High Curb and 7'-6" at 6" High Curb.

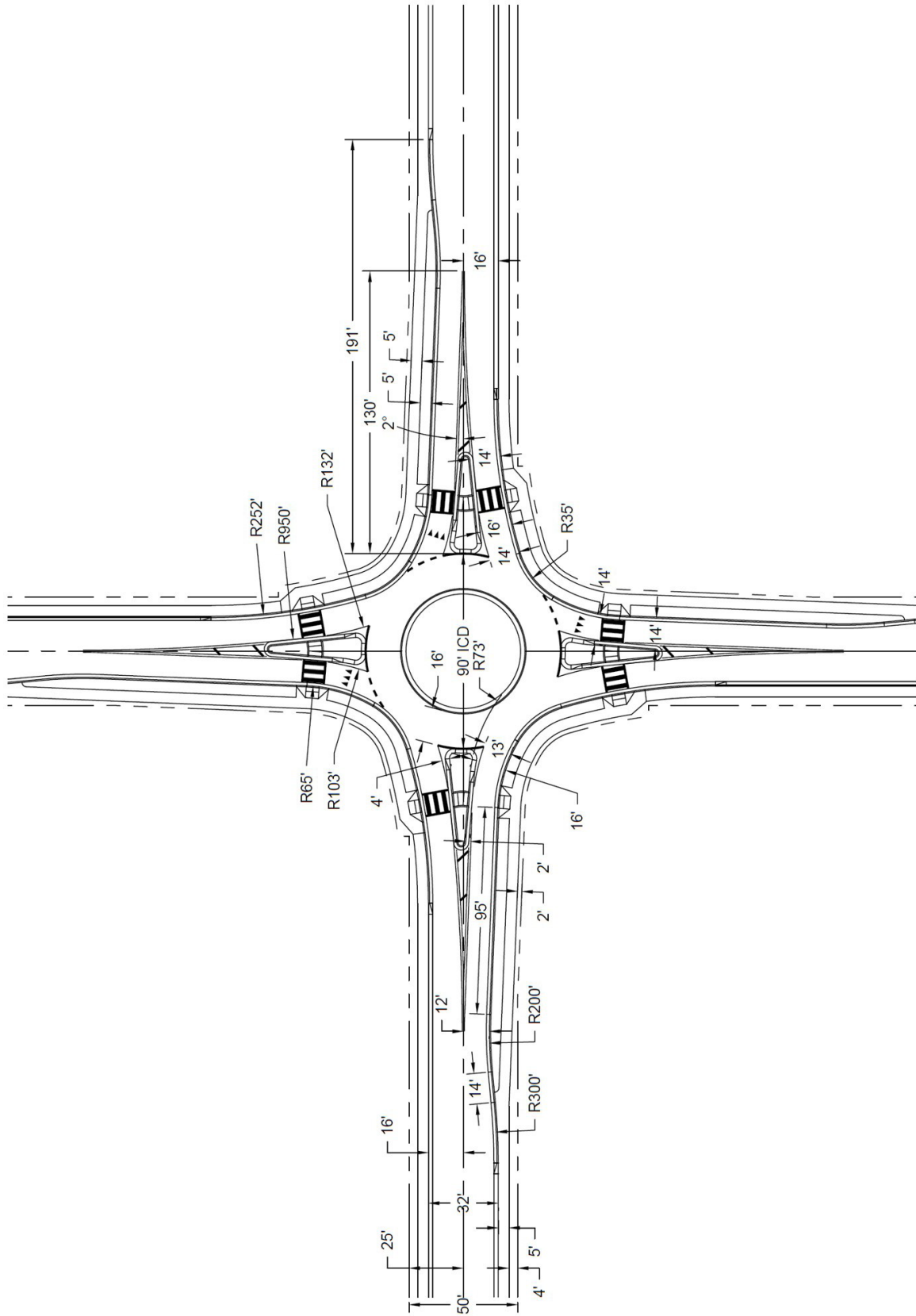

Figure 6.12: Typical Dimensions for Mini Roundabouts

6.2.10 PERFORMANCE CHECKS

A. DESIGN VEHICLE ACCOMMODATION

Adequacy of the roundabout design to accommodate each permitted movement from each lane of the roundabout by each applicable design vehicle as specified in Table 6.3 is to be determined and documented using appropriate vehicle tracking software. Through and turning movement swept path diagrams for Design Vehicle 1 and for Design Vehicle 2, as each is defined in Figure 6.9 are to be included with every roundabout design submittal. Additional guidance for accommodating the swept path of vehicles is provided in NCHRP Report 672 Sections 6.4.7 and 6.5.7.

B. FASTEST PATH

The fastest path is the smoothest, flattest path possible for a single vehicle, a passenger car (P), in the absence of other traffic and ignoring all lane markings, to travel through the entry, around the central island, and out the relevant exit. Figure 6.13 identifies and illustrates the five critical path radii that comprise the fastest path for each permitted movement through the roundabout. These radii consist of R1 – the Entry Path radius, R2 – the Circulating Path Radius, R3 – the Exit Path Radius, R4 – the Left Turn Path Radius, and R5 – the Right Turn Path Radius.

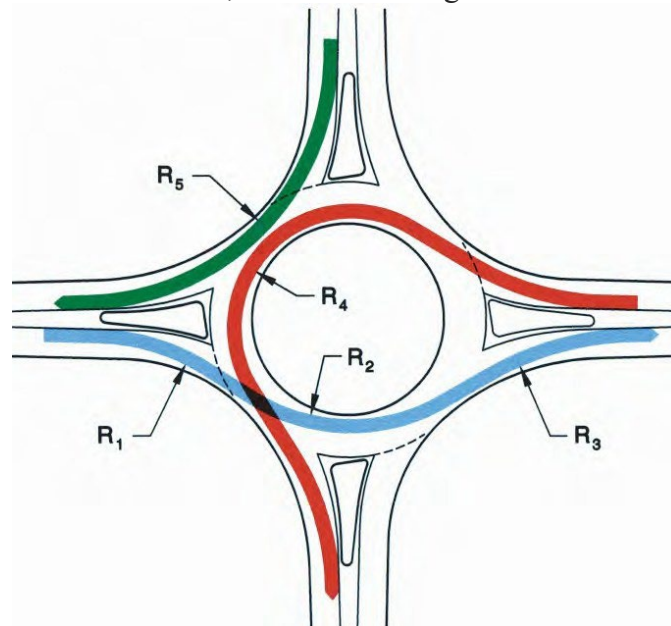

Figure 6.13: Vehicle Path Radii

Source: NCHRP Exhibit 6-47

The ability for a specific geometric configuration to achieve the speed management objective is determined through a process which involves drawing, measuring the radii, and computing (or pulling from a radius-speed relationship table) fastest path speeds for all movements and comparing the results against applicable design criteria. Scaled and sealed drawing documenting fastest paths for all approaches and all movements are to be included within the design documentation to be submitted with every roundabout plan review submittal. Fast path movements include all left turn movements, all right turn movements, and all through movements. Section 6.7.1 of NCHRP Report 672 provides detailed instructions for one acceptable method for graphically constructing the fastest vehicle paths for all critical movements at a roundabout. Another acceptable method applied to a minor collector-local residential roundabout drawing is

shown in Figure 6.14. As many schematics as needed to show all fastest paths clearly shall be produced and submitted. A table that lists the radii of the component curves of each fastest path and the corresponding design speed for the curve is to accompany the fast path drawings.

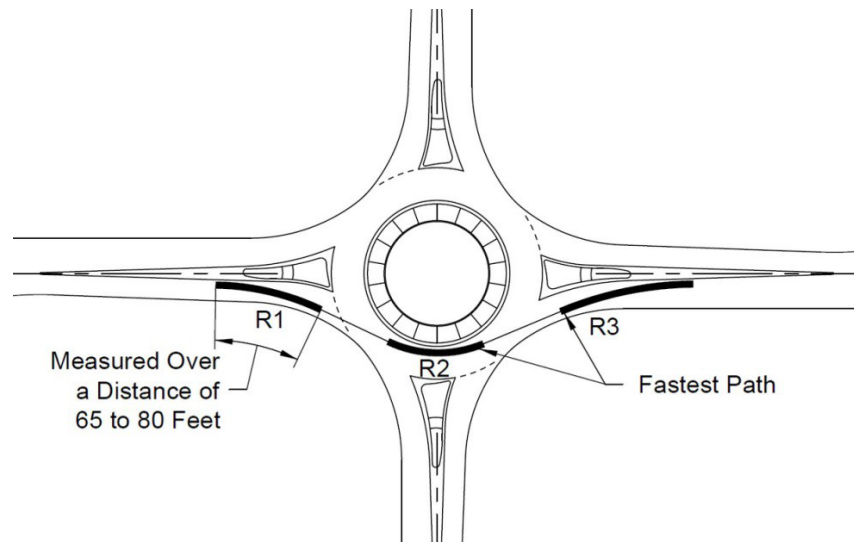

Figure 6.14: Fastest Path Exhibit

C. STOPPING SIGHT DISTANCE

Adequate stopping sight distance must be provided on the roundabout approaches, within the roundabout circulatory roadway, and to the crosswalks on the exits. Approaching driver sight distance is illustrated in Figure 6.15, circulating driver stopping sight distance is illustrated in Figure 6.16, and exiting driver stopping sight distance is shown in Figure 6.17. Anticipated sight distance through the roundabout can be measured using speed-radius relationship information provided in NCHRP Report 672 Exhibit 6-52, and stopping sight distance criteria provided in Section 5.15 of this Manual.

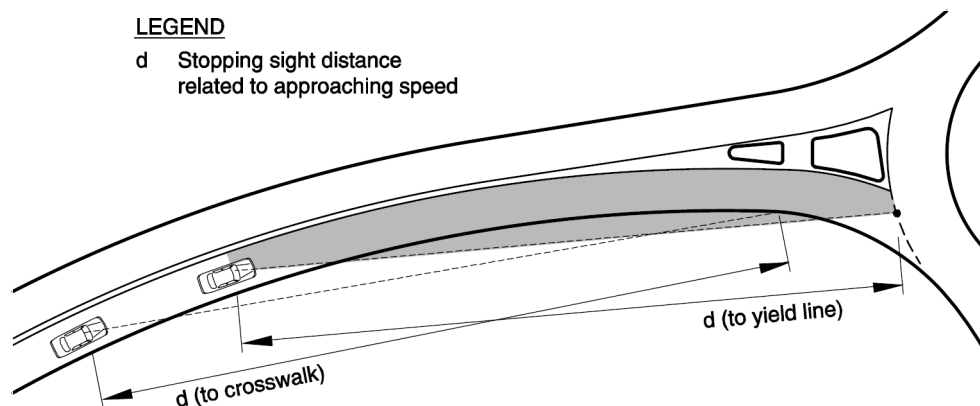

Figure 6.15: Stopping Sight Distance On Approach

Source: NCHRP Report 672 Exhibit 6-55

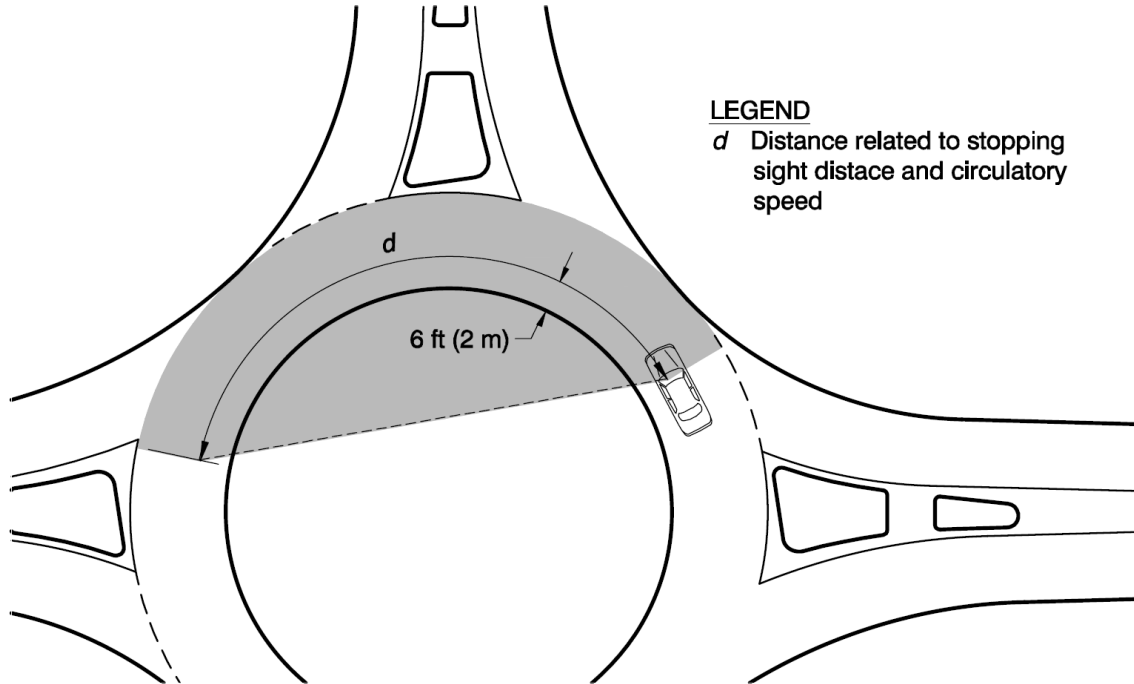

Figure 6.16: Stopping Sight Distance Along Circulating Roadway

Source: NCHRP Report 672 Exhibit 6-56

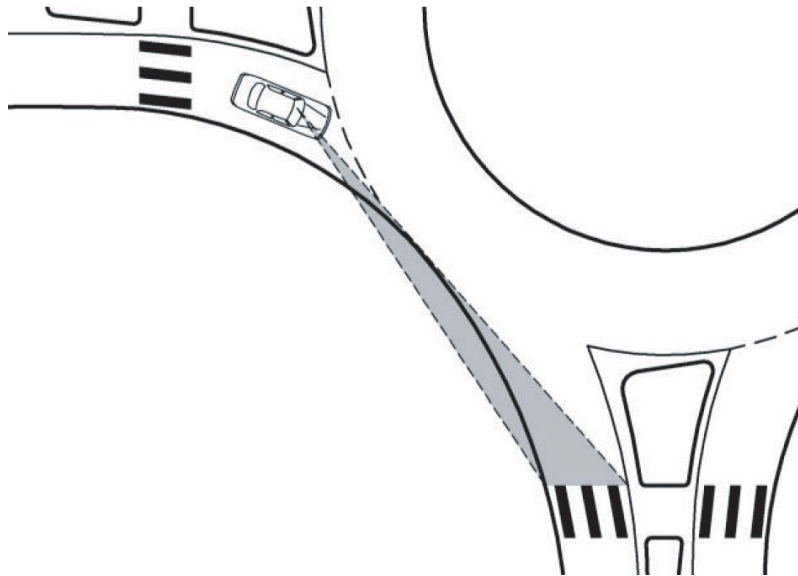

Figure 6.17: Stopping Sight Distance to Crosswalk On Exit

Source: NCHRP Report 672 Exhibit 6-57

D. INTERSECTION SIGHT DISTANCE

Adequate intersection sight distance (sight triangle) is to be provided for approaching traffic on the circulating roadway and on other approach legs to enable the motorist to determine when to enter the roundabout. Figure 6.18 illustrates this concept.

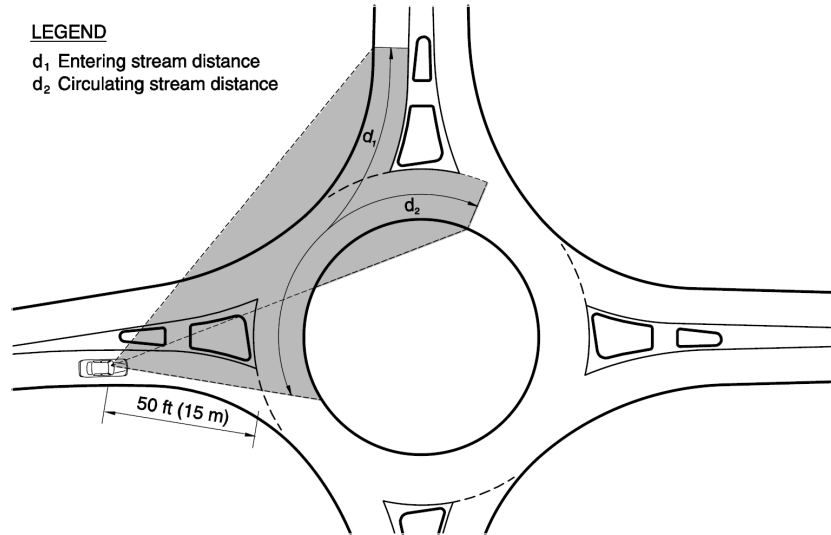

Figure 6.18: Intersection Sight Distance

Source: NCHRP Report 672 Exhibit 6-58

All roundabout design submittals are to include sight distance diagrams consistent with those presented in Figures 6.15 through 6.18 to cover all approaches and circulating segments of the roundabout, as well as a fully dimensioned composite sight distance diagram for use in defining height restrictions for landscaping and other vertical design features within and near the roundabout. Graphic elements of a composite sight distance diagram are presented in Figure 6.19. Sight distance composite diagrams included with design submittals shall be fully dimensioned.

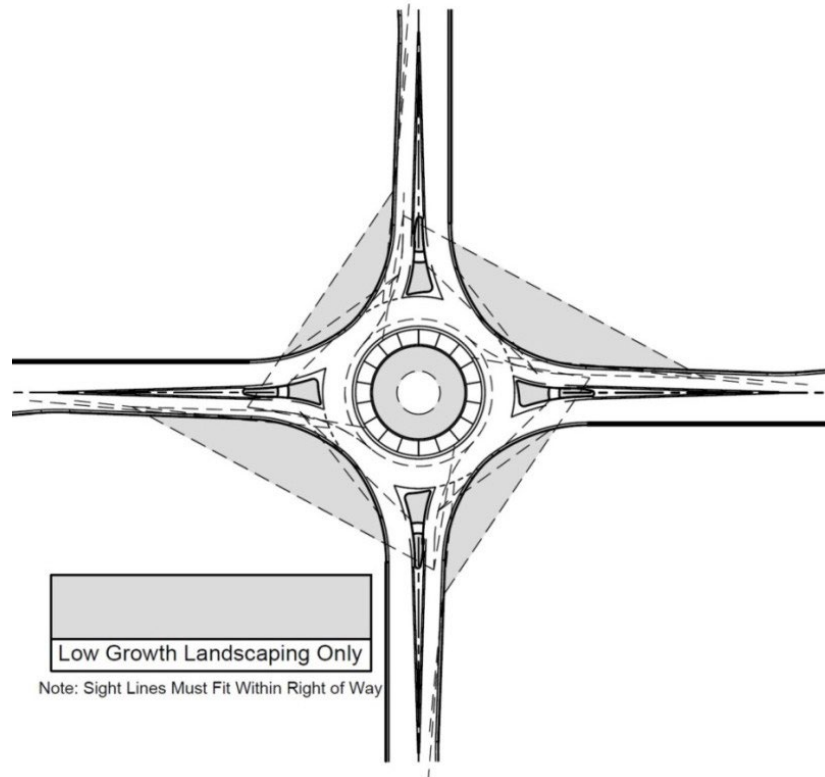

Figure 6.19: Composite Sight Distance Diagram (Prior To Dimensioning)

6.2.11 VERTICAL CONSIDERATIONS

A. CROSS SLOPE

The circulating roadway should be designed with a constant slope toward the outside of the roundabout within the range of 1.5% to 2.0%.

Splitter island areas are to have positive drainage, roadways are to have a minimum of 1.0% cross slope and the longitudinal grade shall not exceed 2%. The pedestrian crossing shall be ADA compliant.

B. CURBING

Roundabout approach and departure roadways shall have vertical curb. The right side of the approach roadway shall have vertical curb throughout the approach deceleration zone. The right side of the departure roadway shall have vertical curb throughout the curbed length of the splitter island. The entire length of the splitter island shall use vertical curb, except on local residential street for mini-roundabouts where splitter islands may need to be traversable to accommodate a WB-50 design vehicle.

The outer curb line of the circulating roadway connecting the approach and departure roadways is to be vertical curb and gutter with a curb height equal to the highest curb height of the connected curb lines.

The central island exterior curb (adjacent to circulating roadway) shall be roll curbing (MAG Detail 220, Type D).

Six inch (6") high vertical curb shall be used for the truck apron's interior curb located along the perimeter of the non-traversable portion of the central island.

The pedestrian walkway through the splitter island shall have along each side vertical curb matching the height of the splitter island curbing.

C. DRAINAGE

Drainage structures when needed should be placed upstream from crosswalks, placement within the entry and exit radii or within the circulatory roadway should be avoided. A primary concern with having inlets located within or adjacent to the circulatory roadway are traffic restrictions required during maintenance operations.

D. GEOMETRIC LAYOUT CONTROL

The use of construction centerline Stations and Offsets to define curb line geometry for roundabouts shall be supplemented or replaced by curve data along the face of curb. Curve data shall consist of radius (R), tangent length (T), central angle delta (Δ), and arc length (L). As a minimum, curve data shall be provided along all roundabout exterior curb lines from the Entry Radius curve through the Exit Radius curve and construction centerline stations and offsets shall be provided at the beginning of the Entry Radius curve and at the end of the Exit Radius curve.

E. ELEVATION CONTROL

Elevation control is to be provided at each curb PC, PT, PRC, and PCC. For the central island curbing (exterior curb and inside truck apron curb) the elevation control points are to include points located by the intersection of the construction centerline extension of each roundabout leg and also along the angle that bisects the centerline extensions of the roundabout legs where the bisecting line intersect the central island exterior curb and the outer curb line of the circulatory road. An example of the application of this guidance is presented in Figure 6.20.

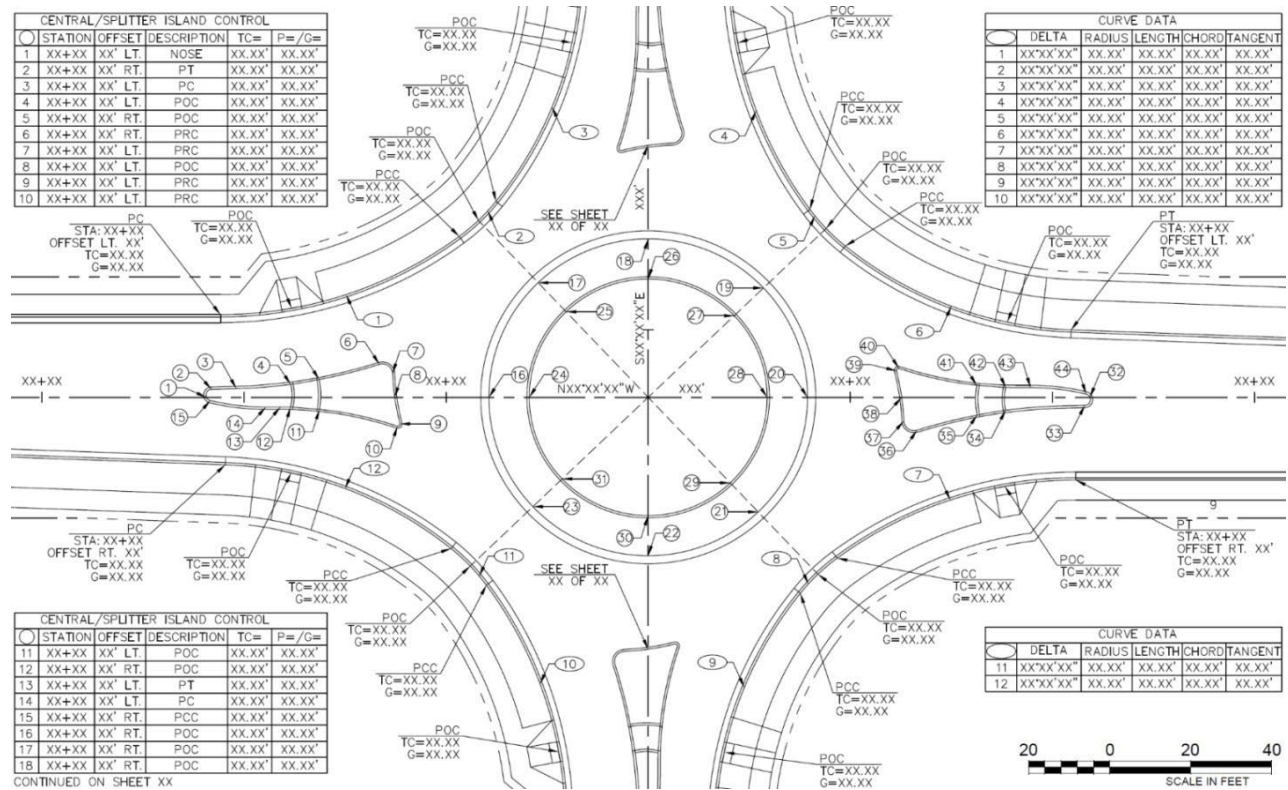

Figure 6.20: Elevation Control Requirements

6.2.12 OTHER DESIGN DETAILS

A. PEDESTRIANS AND BICYCLISTS

Sidewalks shall be provided on all roundabout approaches that connect to existing or planned pedestrian facilities, or where there is anticipated pedestrian demand based on proposed development and/or adjacent land use. Crosswalks and refuge areas shall be provided to connect all roundabout approaches that have sidewalks or mixed use paths. A buffer shall be provided between roadway curb and the sidewalk. See Figures 6.5, 6.6 and 6.13 for sidewalk setback requirements which vary based on adjacent curb height.

Where bicycle lanes are used on approach roadways to multilane roundabouts, optional use bicycle ramps shall be provided to allow bicyclists to use the sidewalk or other adjacent pathway to negotiate the roundabout. Where optional use bicycle ramps are provided, the sidewalk width through the roundabout shall be increased by a minimum of three feet (3'). Between the bicycle street exit and entrance ramps, the minimum sidewalk width through roundabouts shall be eight

feet (8'). The bottom width of curb ramps located along widened portions of walkways shall match the full width of the widened walkway. Optional use bike ramps may be required at urban single-lane roundabouts where high traffic volumes are anticipated. Further information for the design of bicycle accommodations for roundabouts.

Chapter 7 Access to City of Sierra Vista Roadway System

7.1 ACCESS CONTROL

7.1.1 GENERAL

The efficiency and safety of a street or highway depends largely on the number and character of interferences affecting vehicles moving along the facility. Major interferences are caused by vehicles entering, leaving, or crossing the road, at intersecting streets and driveways. In order to minimize crashes and to assure best overall use of the facility by the general public, it is necessary to regulate vehicle movements in and out of abutting developments and cross streets.

With respect to driveways, road users have certain rights of access to abutting property as well as the right to travel on the road with relative safety and freedom from interference. Since these various rights sometimes conflict, the City is given the responsibility for reconciling and satisfying, to the extent feasible, the needs and rights of all road users with respect to driveway location, design, and operation. **When conflicts arise, preference will be given to the safe and efficient use of the road.**

As of the date of the adoption of this section of the Code, existing access points onto Arterials and Collectors may be allowed to remain. Existing accesses are not vested with the property. When there is a change of use, new development, and/or when a lot split/combination occurs, the City of Sierra Vista reserves the right to require the property owner to re-evaluate use of the access(es), as part of their permitting process. When an access to a roadway with a curb and gutter is abandoned, it is to be replaced by a full height curb across the abandoned access and the depression behind the curb is to be filled. When an access to a roadway with a shoulder and ditch is abandoned, it is to be removed and the area graded to match the existing shoulder and ditch.

No development permit or subdivision approval shall be issued unless each lot in the development has frontage or approved public access to a public street. The public streets shall be dedicated and improved to the Street Design Standards of this document. Streets that are contiguous (existing or planned) with a development but reside in the county shall be constructed to minimum County construction standards. Roadways shall be minimum County half width right-of-way or 26 feet, whichever is greater. No development will be permitted when it will generate traffic beyond the street's current carrying capacity within a ¼ mile of the development including pavement width and signalization.

Street alignment will conform to the Traffic Circulation Plan or any adopted specific plans and will be built in accordance with the design standards for the designated street (Arterial, Collector, etc.). The City Engineer may recommend that Council approve minor deviations in alignment of a street when it is impractical to conform to the exact alignment shown on the Traffic Circulation Plan because of adverse topography, drainage problems, existing development, or traffic safety.

The minor deviation must not affect the public purpose of the street and must maintain a not-to-exceed distance of 1,500 feet between an Arterial or Collector street and a parallel collector street.

7.1.2 ACCESS TO STATE HIGHWAYS

Access to State highways is regulated by the Arizona Department of Transportation (ADOT). The City of Sierra Vista will not review changes to an existing access or any new access which is in State right-of-way. Encroachment permits for access to State highways must be obtained directly from ADOT. The City shall review requests for new access where any portion of the access is in City right-of-way.

7.1.3 ACCESS TO CITY STREETS

Encroachment permission for access to streets must be obtained directly from the City. The City shall review a request for new accesses where any portion of the access is in City right-of-way.

Aa Traffic Impact Analysis (TIA) shall be required of developments, or additions to existing developments, generating 100 or more trips during the morning or afternoon peak hours on the adjacent street. For developments generating less than 100 peak hour trips, a Traffic Impact Statement (TIS) may be required.

A change in the use of any property may necessitate a change in its access. To ensure safe and efficient operation of both the roadway and driveway accesses, a review of the access needs (locations and design) of existing facilities is required when the use of a facility's function changes. Changes in the number and location of access points together with a design for each access point shall be submitted to the City of Sierra Vista for approval.

A Traffic Impact Statement or Analysis may be required for a property when there is a change in use or zoning; or when property is combined or subdivided.

Once a Traffic Impact Study and/or Traffic Impact Analysis has been submitted and approved, the development shall commence within 2 years of the TIS or TIA approval date. The developer/owner may request for an extension of the approval every 2 years, for a maximum of 10 years. Depending on the surrounding development conditions at the time, the City reserves the right to require the owner to update or create a new report for resubmittal and approval at any time after the first expiration date.

Access to Parking from an Alley. Any parking lot may use an abutting alley for direct access to parking spaces; provided that the full width of the alley is dedicated to the public and fully paved with two inches of asphaltic concrete over six inches of aggregate base course or four inches of Portland Cement concrete reinforced with #8, 6-inch by 6-inch wire mesh over a sub-base compacted to 95 percent density and property drained to prevent impoundment of surface water.

7.1.4 ACCESS TO COUNTY ROADS

Access to County Roads is regulated by Cochise County. The City of Sierra Vista will not review changes to an existing access or any new access which is in County right-of-way. Encroachment permits for access to County Roads must be obtained directly from Cochise County. The City shall review requests for new access where any portion of the access is in City right-of-way.

7.5 DRIVEWAYS

7.5.1 DEFINITION

A driveway is any access constructed within the public right-of-way, connecting the public roadway with adjacent property or properties.

Driveways are private facilities constructed under permit within public right of way. The facility owner is responsible for maintenance and repair of driveway pavements, driveway culverts, and driveway embankment slopes.

The principles of intersection design apply directly to driveways. One important feature of a driveway is controlling the location for accessing the road by the elimination of large graded or paved areas adjacent to the traveled way that allow drivers to enter or leave the street randomly.

7.5.2 DRIVEWAY TYPES

- A. Single Family Residential: A driveway that provides access to a single family residence or lot.
- B. Multi-Family Residential: A driveway that provides access to a duplex or an apartment building that serves 2 to 50 dwelling units.
- C. Commercial: A commercial driveway is one providing access to an office, retail, or institutional building or complex, or to an apartment building having more than 50 dwelling units.
- D. Industrial: An industrial driveway is one directly serving truck movements.
- E. Private Road: A driveway that provides, or has the capability of providing, access to more than one (1) single family residence or lot; or development site.

See Section 7.6 for additional information.

7.5.3 SURFACE REQUIREMENTS FOR DRIVEWAY AND ROADWAY CONNECTIONS

All new driveways and all new roadway connections to a paved City of Sierra Vista Road shall be paved within the City right-of-way. “Paved” includes asphaltic concrete, Portland cement concrete, and other materials approved by the City Engineer or authorized representative.

New construction that widens a roadway or converts an unpaved roadway into a paved roadway shall also pave existing driveway connections located within the project limits in compliance with Table 7.1.

TABLE 7.1: SURFACE REQUIREMENTS FOR DRIVEWAY CONNECTIONS		
Roadway Edge	Existing Driveway Conditions	Driveway Surface Materials
Uncurbed	Concrete, asphalt, or hard surfaced custom decorative driveway within 5' of the R/W	Asphalt Paved Turnout (MAG Detail 205) connecting to the existing driveway surfacing.
Uncurbed	Earthen or gravel driveway within and 5' beyond the R/W	If an acceptable vertical profile can be obtained within the R/W then provide: Asphalt Paved Turnout (MAG Detail 205) to within 5' of the R/W and provide a graded transition of ABC or existing gravel between the Paved Turnout and R/W. If an acceptable vertical profile needs to extend beyond the R/W then provide: Asphalt Paved Turnout (MAG Detail 205) to the R/W; beyond the R/W provide ABC surfacing to the match point with the existing driveway.
Concrete Curb	Concrete Driveway within 5' of the R/W	Concrete driveway entrance (SV 262) plus concrete driveway pavement to connect with the existing driveway.
Concrete Curb	Asphalt Driveway within 5' of the R/W	Concrete driveway entrance (SV 262) plus asphalt driveway pavement to connect with the existing driveway.
Concrete Curb	Gravel surfaced driveway within 5' of the R/W	Concrete driveway entrance (SV 262) plus asphalt driveway pavement between the driveway entrance and the existing driveway.
Concrete Curb	Earthen driveway within and 5' beyond the R/W	Concrete driveway entrance (SV 262) plus asphalt driveway pavement between the driveway entrance and the existing driveway surface.
Concrete Curb	Decorative Custom Driveway within 5' of the R/W	Concrete driveway entrance (SV 262) and coordinate the material with the property owner.

7.6 DRIVEWAY CHARACTERISTICS

7.6.1 SINGLE FAMILY RESIDENTIAL

Driveways serving a single-family residence shall have a minimum width of 16 feet and a maximum width of 30 feet within City right of way. For garages entrances located within 25 feet of the right-of-way line, the driveway width may equal the width of the garage opening.

Driveway connections to vertical curbed roadways shall use a concrete depressed curb driveway entrance (SV 262) having a minimum entrance width of 16 feet and a maximum width of 30 feet. The driveway centerline must match the centerline of the driveway entrance.

Driveway connections to rolled curbed roadways shall construct one of the following driveways:

A. Existing Rolled Curb

1. With existing sidewalk – The area between the back of sidewalk and right of way shall be gravel, pavers, thick concrete, or asphaltic concrete.
2. Without existing sidewalk – The area between the back of curb and the right of way shall be gravel, pavers, concrete, or asphaltic concrete.

For a thickened sidewalk, use a concrete depressed curb driveway entrance (SV 262) having a minimum entrance width of 16 feet and a maximum width of 30 feet. The driveway centerline must match the centerline of the driveway entrance.

Driveways connecting to arterial or major collector streets shall include adequate turnaround space on the private property, or a circular driveway, to eliminate the need to back a vehicle onto the roadway.

7.6.2 MULTI-FAMILY RESIDENTIAL

Driveways serving multi-family developments with 5 to 50 dwelling units shall be designed in accordance with the guidelines of this section. Driveways serving multi-family developments of more than 50 dwelling units shall be designed as commercial driveways in accordance with Section 7.6.3. Driveways serving less than 5 dwelling units shall be designed as single family residential driveways in accordance with section 7.6.1.

Driveways connecting to local or minor collector roadways with vertical curbing shall use a 30-foot-wide concrete depressed curb driveway entrance (SV 262). The driveway centerline shall match the centerline of the driveway entrance, and a 5:1 taper rate shall be used to match from the driveway entrance width to the driveway width. Driveway connections to a major collector or arterial street with vertical curbing shall use a concrete depressed curb driveway entrance (SV 262). A return type driveway (SV251) may be used if approved by the City Engineer. The concrete depressed curb driveway entrance shall be 36 feet wide. The driveway centerline shall match the centerline of the driveway entrance, and a 5:1 taper rate shall be used to transition from the driveway entrance width to the driveway width. A return type driveway shall be 30 feet wide with a minimum return radii of 6 feet. The City may require driveways to be widened to 40 feet to provide for a separate left turn lane.

7.6.3 COMMERCIAL AND INDUSTRIAL DRIVEWAYS

A commercial driveway provides access to an office, retail, or institutional building complex, or to an apartment building having more than 50 dwelling units. Such developments are customarily served by trucks as an incidental rather than a principal driveway use. Industrial plant driveways whose principal function is to serve administrative, or employee parking lots are also considered commercial driveways.

An industrial driveway is one directly serving substantial numbers of truck movements to and from an industrial facility, warehouse, or truck terminal. A centralized retail development, such as a community or regional shopping center, may have one or more driveways specially designed, signed, and located to provide access for trucks. These are also classified as industrial driveways.

Driveways serving commercial and industrial developments shall be designed based on the types and volumes of vehicles anticipated to use the driveway, along with the traffic volumes, number of lanes, and operating speed of the connecting roadway. Depressed curb driveway entrances are standard for curbed roadways. Return type driveways may be used for high volume driveways with the approval of the City Engineer.

The maximum depressed curb driveway entrance width is 40 feet. The concrete depressed curb driveway entrance will be wider than the required driveway lane widths to facilitate off tracking of turning vehicles. A 5:1 or flatter taper rate shall be used to transition from the driveway entrance width to the driveway width.

Return type driveways are generally restricted to high volume facilities. The return radii and lane widening requirements are adjusted to accommodate off tracking of turning vehicles.

Driveway connections to uncurbed roadways shall be asphalt paved turnouts (MAG Detail 205 Type A, B, or C). The turnout design shall contain vehicle off tracking on the pavement for all vehicles types anticipated to use the driveway.

7.6.4 PRIVATE ROADS

A private road is any roadway that carries traffic, that may or may not be contained within an easement or dedicated right-of-way, but that is not owned or maintained by a governmental entity.

The design of private road connections to the public road system shall be based on roadway vehicle mix and volumes. Very low-volume private road connections to roadways shall be designed as Commercial or Industrial driveways. Private roads with higher traffic volumes that would connect to roadways shall be designed in accordance with the requirements of Chapter 6 Intersections. Intersection design shall comply with design requirements of a roadway classification acceptable to the City Engineer.

A private road may be within an access easement that serves or will serve more than one lot. Private road connections that would provide access to a roadway for more than one property shall be designed as a Joint Access as described in Section 7.9.3. Parcels adjoining the private road shall access the road system via the private road and will not be provided access directly to the road system without the approval of the City Engineer.

The ultimate improvements associated with the private road connection with the roadway shall be

required to be constructed concurrent with the development/improvement to be constructed with the issued building permit that has frontage along the right-of-way. The minimum width of private road connections within right-of-way shall be 26 feet.

7.7 DRIVEWAY DESIGN

7.7.1 RESTRICTION OF TURNING MOVEMENTS

Where necessary for the safe and efficient movement of traffic, The City may require access points to be geometrically designed so as to provide for only limited turning movements. The restriction of turning movements should not affect the number and location of access points as specified elsewhere.

A full access driveway (proposed, new, or change to existing) that causes the LOS to be less than D for any movement may be restricted to a right in/right out access only.

7.7.2 ISLANDS FOR LIMITED MOVEMENT ACCESSES

Figures 7.1 - 7.3 illustrate configurations for limited movement accesses. Islands are to be designed with vertical curbs and are to accommodate the turning path of a WB-67 design vehicle. The ends of the islands should typically be provided with a minimum 4-foot back of curb radii. Deceleration or acceleration lanes may be required to be incorporated into the design. Reference the AASHTO publication *A Policy on Geometric Design of Highways and Streets* for channelizing island design details.

The City may permit or require the installation of a center median on the adjacent public street as an alternative to driveway islands.

An ADA compliant pedestrian access route shall be provided across the driveway and be contained within the public right-of-way.

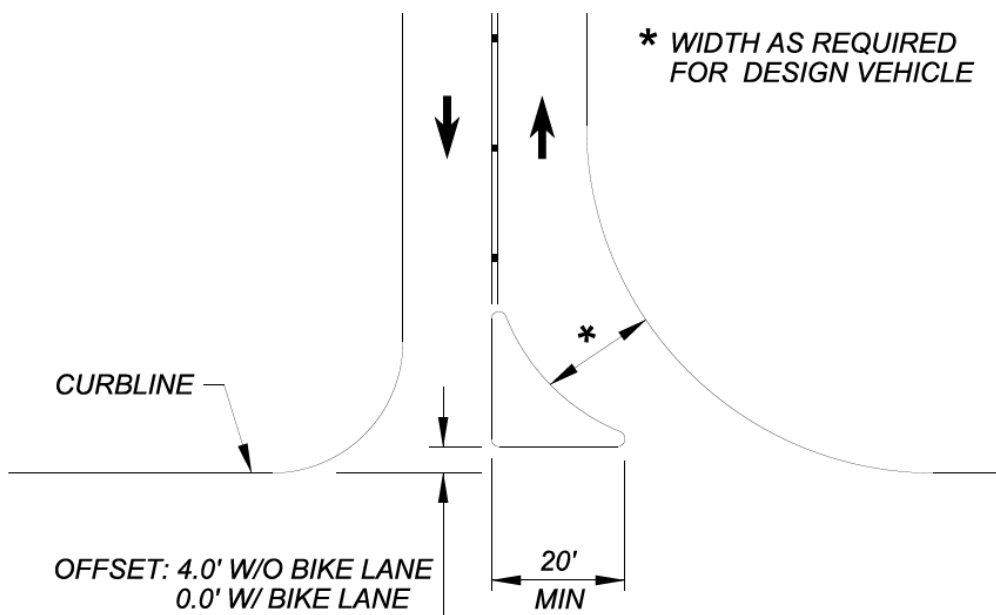

Figure 7.1: Right-In, Right-Out, Left-Out Access Design

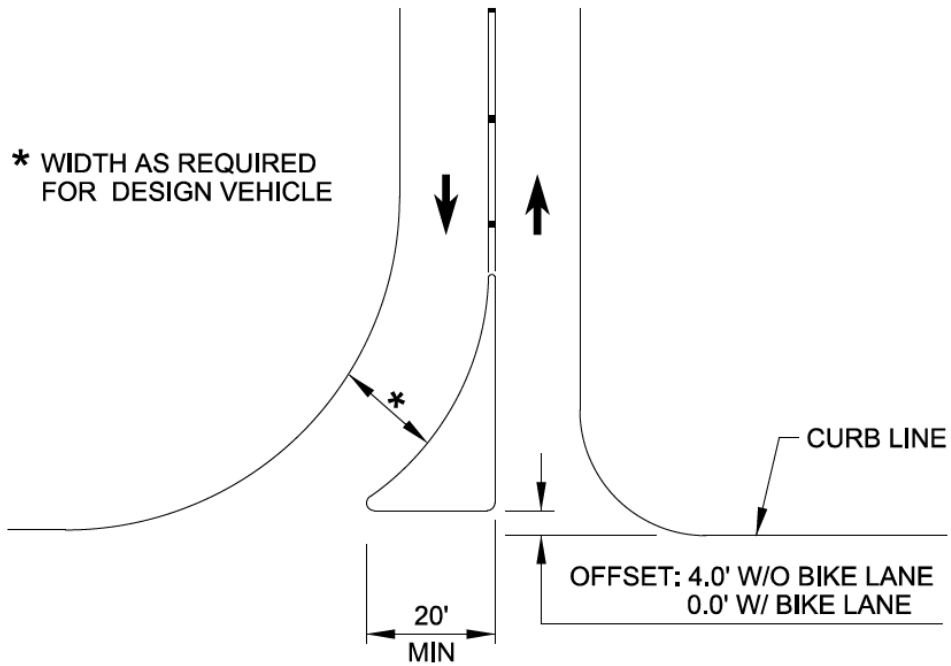

Figure 7.2: Right-In, Right-Out, Left-In Access Design

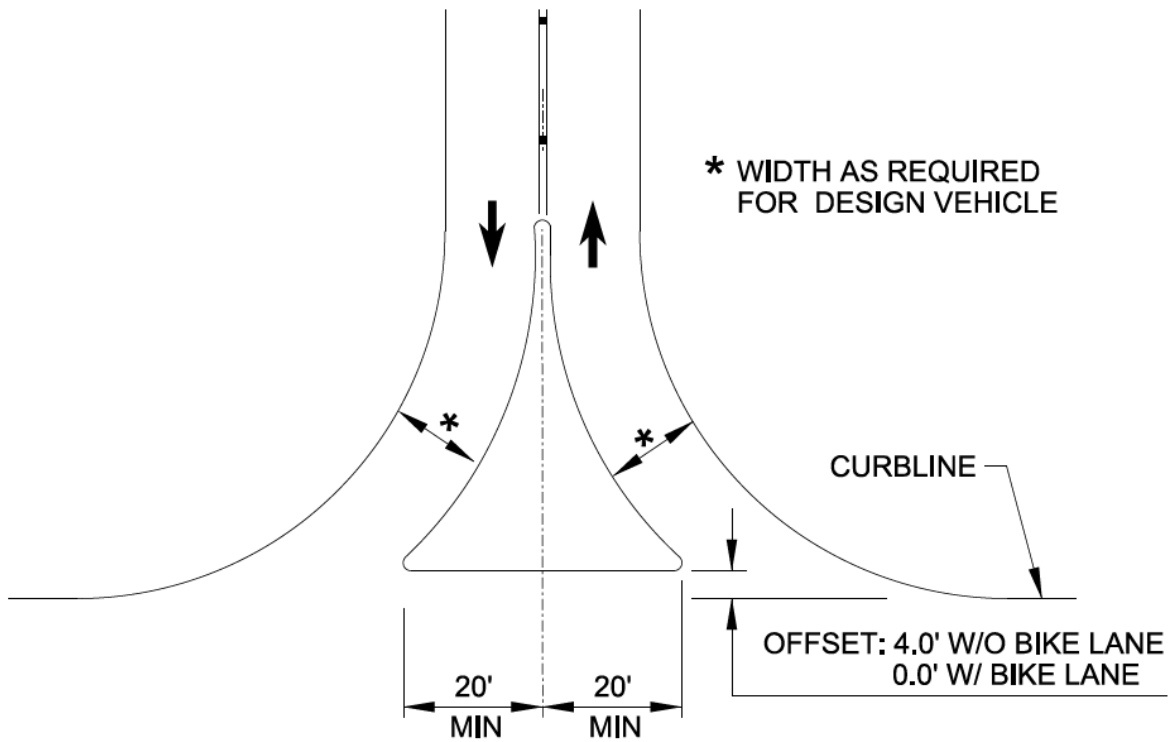

Figure 7.3: Right-In, Right-Out Access Design

7.7.3 RADII AND WIDTHS

Section 7.6 identifies characteristics to be included in the design of driveways. Where customized driveways are required, vertical curb returns will be allowed and/or required by The City. Customized driveways will be required wherever islands to control turning movements are required.

The design of multifamily, commercial, and industrial driveways are to be checked using an appropriate design vehicle turning template (use most conservative vehicle of those anticipated at the property- fire trucks, delivery trucks, school buses, refuse trucks, etc.) to ensure vehicle off-tracking is contained on driveway pavement. Drainage impacts are to be taken into consideration in the design of driveway accesses.

7.7.4 RELOCATION OF UTILITIES, STRUCTURES, AND TREES

Prior to commencing any work, arrangements for the necessary removal or relocation of any public utilities, structures, trees, or plantings must be made by the developer or permittee with the person or persons having ownership or control thereof. Removal and relocations shall be accomplished at no expense to the City. All relocations shall be in accordance with City and/or owners standards, the most conservative prevails.

7.7.5 DRIVEWAY SIGHT DISTANCE

Departure sight triangles shall be determined for driveways using the same procedure as required in Chapter 6 INTERSECTIONS except the speed used to determine the departure sight triangle shall be as indicated in the following table.

Road Classification	Speed for Departure Sight Triangle Calculations	Set-Back from Edge of Pavement
Local	Posted Speed +5 mph	14.5'
Collector	Posted Speed +5 mph	14.5'
Arterial	Posted Speed +10 mph	18.0'

Driveway sight distance shall be calculated using the time gap for the vehicle type indicated in Table 7.2.

Major Road Classification	Minor Road Driveway Type	Vehicle 1	
		Right Turn	Left Turn
Arterial	Commercial Industrial	Combination Truck	Combination Truck
Arterial	Residential	Passenger Car	Passenger Car
Collector	Commercial Industrial	Single Unit Truck	Single Unit Truck
Collector	Residential	Passenger Car	Passenger Car
Local	Commercial Industrial	Single Unit Truck	Single Unit Truck

Local	Residential	Passenger Car	Passenger Car
-------	-------------	---------------	---------------

Driveway locations are to be evaluated to determine whether a sight obstruction exists, such as buildings, fences, signs, vegetation, parked vehicles, horizontal or vertical highway alignments, etc. The sight distance requirements for passenger cars are based on a 3.5 foot eye height and a 3.5 foot object height. The distances for trucks are based on a 7.6 foot eye height and a 3.5 foot object height.

If the sight distance is not adequate, consideration should be given to the following options:

- A. Removing the sight obstruction
- B. Relocating the driveway to a more favorable location along the frontage
- C. Prohibiting critical movements at the driveway
- D. Relocating access to another street, a frontage road, or a joint access location

In all cases, stopping sight distance must be provided.

7.7.6 DRIVEWAY PROFILES

Adequate design of driveway grades and profiles are to consider the basic functions of the adjacent street, the site that the access driveway serves, and the type of vehicles anticipated to use the driveway.

The profile of driveway connections to uncurbed roadways is to match the roadway pavement and shoulder grades; an independent driveway profile may begin at the outer edge of the roadway shoulder.

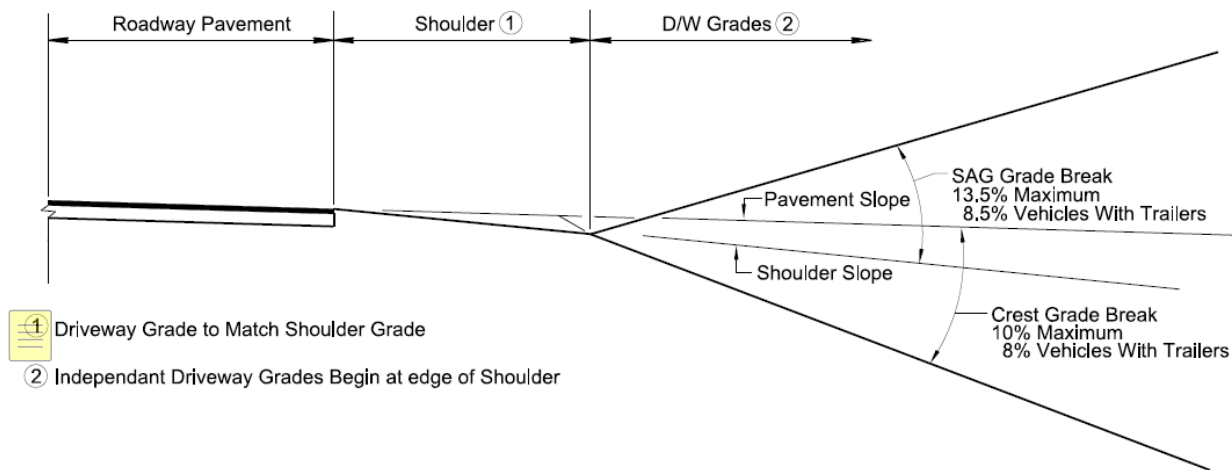

- ① Driveway Grade to Match Shoulder Grade
- ② Independent Driveway Grades Begin at edge of Shoulder

7.4 RURAL DRIVEWAY GRADES

Driveway profiles are to provide sufficient clearance between the vehicle and the driveway surface to prevent high centering and hang-ups.

The ‘maximum’ driveway grade break changes identified in Table 7.3 will prevent high centering and hang-ups for most passenger cars. The ‘recommended’ driveway grade changes identified in Table 7.3 should be used for any vehicles with trailers to prevent high centering and hang-ups. Successive crest grade breaks and successive sag grade breaks are to be spaced no closer than the

spacing between the front and rear axles. For design of driveway profiles twenty feet (20') is the minimum distance to be used between successive crest grade breaks or successive sag grade breaks unless the sum of the grade breaks is less than the maximum design grade change. For single family residential driveways used only by passenger vehicles not pulling trailers the minimum distance between successive grade breaks may be reduced to twelve feet.

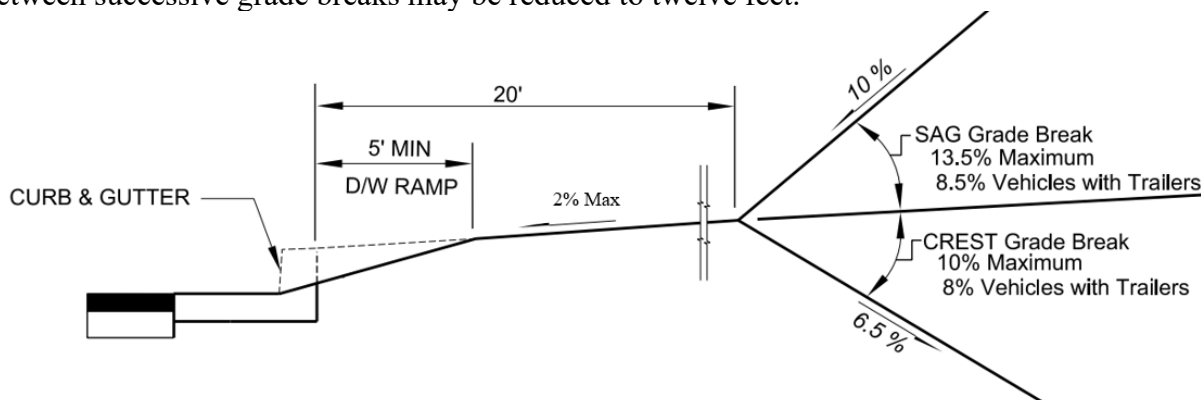

7.5: URBAN DRIVEWAY GRADES

The maximum grade change without a vertical curve for a crest condition is 10% for passenger cars. The maximum grade change without a vertical curve for a sag condition is 13.5% for passenger cars. Vehicles with towed trailers cannot exceed a grade change of 8% for crest conditions and 8.5% for sag conditions. Access to properties that can accommodate vehicles with trailers must be evaluated by the Design Engineer if the grade change exceeds the maximum values in Table 7.3. The Design Engineer must demonstrate the proposed driveway grade change will not cause the vehicle or trailer to contact with the roadway surfaces when traversing the driveway.

TABLE 7.3: DRIVEWAY % GRADE CHANGES WITHOUT A VERTICAL CURVE		
	Maximum (Passenger Cars)	Maximum (Vehicles w// Trailers)
Crest Condition	10	8
Sag Condition	13.5	8.5

7.7.7 DRIVEWAY TYPICAL SECTIONS

Driveway typical sections shall define embankment and cut slope requirements. Side slopes located within the roadway clear zone are transverse roadway slopes that are to be 1V:6H or flatter (1V:10H is the preferred rate along high-speed roadways).

If the Design Engineer demonstrates to the City Engineer that this requirement cannot be accomplished, the Design Engineer shall refer to the AASHTO Roadside Design Manual, latest edition, for alternatives; and submit a formal request to the City Engineer for review and approval.

7.7.8 DRIVEWAY ANGLES

Two-way driveways and one-way driveways that are entering the roadway are to be aligned perpendicular (90°) to the roadway without angle points within the right of way. Driveway angle points when needed are to be located on private property. If conditions exist that prevent a perpendicular roadway connection, the Design Engineer shall submit a formal request to the City

Engineer for review and approval. Under no circumstance will an angle less than 75° be approved.

7.7.9 DRAINAGE

Please refer to the City Development Code Section 151.08.008 Surface Drainage and Storm Sewer Systems for design requirements:

https://codelibrary.amlegal.com/codes/sierravista/latest/sierravista_az/0-0-0-19239

Driveways along curbed roadways shall not allow street flow to be diverted. Drainage conditions downstream of the driveway shall not differ from that which would exist if the driveway was not present.

Driveways crossing roadside drainage ditches and channels shall not reduce the design capacity of the ditch or channel. If a culvert is installed, the water surface elevation at the culvert inlet shall be contained within the ditch or channel. Any increased potential for erosion resulting from driveway construction shall be mitigated. Ditch and channel flows shall not encroach onto roadway pavement at driveway locations.

Driveway culverts located within the roadway clear zone shall follow the AAHSTO Roadside Design Guide, latest edition.

7.7.10 SIDEWALKS

Driveways shall have an ADA compliant crossing for pedestrians contained within the right-of-way and shall be constructed in accordance to the City's latest Construction Standard Detail.

7.8 NUMBER OF DRIVEWAYS

The number of driveways is dependent upon the size and use of the property. Each parcel is limited to one driveway. The driveway(s) are to satisfy the minimum driveway spacing criteria, as identified in Section 7.9.

7.8.1 Site Access

A. Commercial and Industrial Sites

Commercial and industrial sites are limited to one access per site. The site shall accommodate internal circulation needed for emergency and/or refuse vehicles to enter and exit the site.

When a commercial or industrial site fronts two or more streets, generally access shall be taken from the street that has the lower functional classification. Should the streets have the same functional classification, then the street with the least amount of traffic in a 24 hour period, per the latest Public Works traffic counts, shall be used for access. Factors such as lot configuration shall be taken into consideration to evaluate access location(s).

Where a property has access to more than one road, access may be limited to the lowest volume road where the impacts of a new access will be minimized. Access on higher volume roads may be denied.

B. Multi-family Developments

Multi-family developments and sites shall be allowed one access for the first 50 units. Two accesses shall be required for sites that have over 50 units. The site shall accommodate internal circulation needed for emergency and/or refuse vehicles to enter and exit the site.

C. Residential Subdivisions

The number of accesses for residential subdivisions shall be based upon the chart below:

<i>LOTS</i>	<i>ACCESS</i>
1-100	2 access
101-200	3 accesses
201-300	4 accesses
301-more	Determined by City

Considerations such as type of use, size of site, location, safety, and other site considerations shall be used to evaluate access location(s).

During construction, the second access to single family residential subdivisions shall be completed prior to the construction of 30 homes in the subdivision. Completed is defined as all-weather access with complete drainage improvements and pedestrian facilities such as sidewalks and shared use paths.

Subsequent access thresholds for completion are determination of the chart above.

Subdivisions shall have one access that connects to a Collector roadway. Subdivisions with more than 500 lots shall have at least two accesses that connect to a Collector roadway.

At least two accesses shall be separated by a minimum of 1,000 feet when feasible.

The stated access requirements are in addition to any emergency vehicular accesses such as a breakaway gate or other such devices that are mandated by the Fire Department.

Where access must be provided across land not owned by the subdivider, the subdivider shall at a minimum, provide at least 50 feet of right-of-way and construct a street of sufficient width to accommodate two-way traffic (26 foot minimum).

The above requirements may be reduced if configuration of the subdivision or existing conditions makes these requirements impractical.

The stated access requirements are in addition to any emergency vehicular accesses such as a breakaway gate or other such devices that are mandated by the Fire Department and Police Department.

7.8.2 ADDITIONAL DRIVEWAYS

Additional driveways may be needed and provided under the following conditions:

- A. If the daily volume using one driveway would exceed 1,500 vehicles (both directions).
- B. If traffic using one driveway would exceed the capacity of a stop-sign-controlled intersection during one peak street traffic hour or the peak site traffic hour.
- C. If a traffic analysis shows that the traffic conditions warrant two or more driveways, and such driveways will not negatively impact traffic flow. When traffic flow on the City roadway will be negatively impacted, additional lanes may be required.

Additional requests for accesses shall be submitted to the City for approval. The City reserves the right to request a traffic impact analysis or traffic impact statement from the Design Engineer if additional information is needed to support the request for additional accesses.

7.8.3 TEMPORARY ACCESS

Temporary access may be granted to undeveloped property prior to development of a final plan if access is needed for construction or preliminary site access. Temporary accesses are subject to removal, relocation, or redesign after final development plan approval. A right of way permit shall be secured before any work can begin.

Secondary access for emergency vehicles must be provided for all subdivisions and all other developments. Secondary access for emergency vehicles shall be usable in all weather conditions.

7.8.4 LARGE DEVELOPMENTS

For large developments, the City Engineer may require the developer to consolidate access traffic to a single point which may be signalized. Driveway signals must be located to provide satisfactory signal progression for through traffic on the public road.

7.9 DRIVEWAY LOCATIONS

The edge of all driveways shall be at least 50' from the near edge of pavement or the near curb line of an intersecting street. The driveway spacing and driveway corner clearance distances shown for arterial and major collector roads in Section 7.9 are based on providing spacing equal to the stopping sight distance of the roadway being accessed. These location standards are desirable but may not be achievable for all situations. When a non-standard situation occurs that prevents compliance with the standards or the standards cause undue hardship, submit to The City for evaluation a proposed installation together with documentation that justifies a need to deviate from the standard. A traffic analysis may be required to show the proposed non-compliant installation will not adversely impact traffic or be detrimental to public safety.

7.9.1 DRIVEWAY LOCATION COORDINATION

The location of a new proposed driveway or the relocation of an existing driveway can be crucial to public safety as well as providing efficient access to the property. Full access (all movements) driveways need to be located to minimize conflicts with adjacent and opposite driveways. For larger projects with proposed driveways on arterials, the locations along with LOS discussions are to be included in a traffic impact study.

Proposed driveways should be aligned with any existing driveways on the opposite side of the roadway to reduce conflicts. If conditions prevent alignment and require offset driveways to be constructed, the left turn movements should not overlap each other. Offset driveways shall be designed so the left turn movements do not share the same space in a two-way left turn lane or future two-way left turn lane. Where lots are not large enough to allow accesses on opposite sides of the street to be aligned, the center of driveways not in alignment should be offset a minimum of 250 feet on all major collector roads, and 360 feet on all industrial and arterial roads. Greater distances may be required due to left turn storage lane requirements.

The distance between an access and an intersection shall be measured from the edge of the intersection right-of-way to the center line of the access. The separation between intersections shall be measured from centerline to centerline.

7.9.2 DRIVEWAY SPACING

The distance between adjacent driveways must be adequate to allow driveway vehicles to safely queue, accelerate, decelerate, and cross conflicting traffic streams without excessive interference with through traffic, or traffic using adjacent driveways.

The minimum distance between driveway centerlines along arterial roadways shall be at least 360 feet.

The minimum distance between driveway centerlines along collector roadways shall be at least 250 feet.

7.9.3 JOINT ACCESS

The use of joint access driveways connecting to arterial and collector roads is encouraged; fewer access points improve the overall operation of the roadway. Joint access will be required for two adjacent developments where a proposed new access will not meet the spacing requirements set

forth in this section. Joint access must be approved by the City Engineer or an authorized representative.

Where parking facilities and driveway access is shared by adjoining developments, an ingress/egress easement shall be recorded authorizing and declaring the purpose and limits of the property to be used.

7.9.4 DRIVEWAY CORNER CLEARANCE FOR ARTERIAL AND COLLECTOR ROADS

Arterial-arterial and arterial- collector intersections may become signalized at a future time and shall be treated as signalized intersections whether or not a signal currently exists. Driveways located near any arterial or collector intersection shall meet the Minimum Corner Clearance requirements shown in Table 7.4 and Figure 7.6. Table distances are the minimum clear distance between the edge of the roadway and the edge of the driveway.

TABLE 7.4: MINIMUM CORNER CLEARANCES		
Distance	Functional Classification of Road	
	Arterial (ft.)	Collector (ft.)
A	360	250
B	180	125
C	360	250
D	360	250
E	75	75

- A. Distance downstream from intersection to a fully directional access.
- B. Distance upstream from a intersection to a right in / right out access.
- C. Distance upstream from a intersection to a fully directional access.
- D. Distance downstream from a intersection to a right in / right out access.
- E. Offset distance from a median break to a right in / right out access.

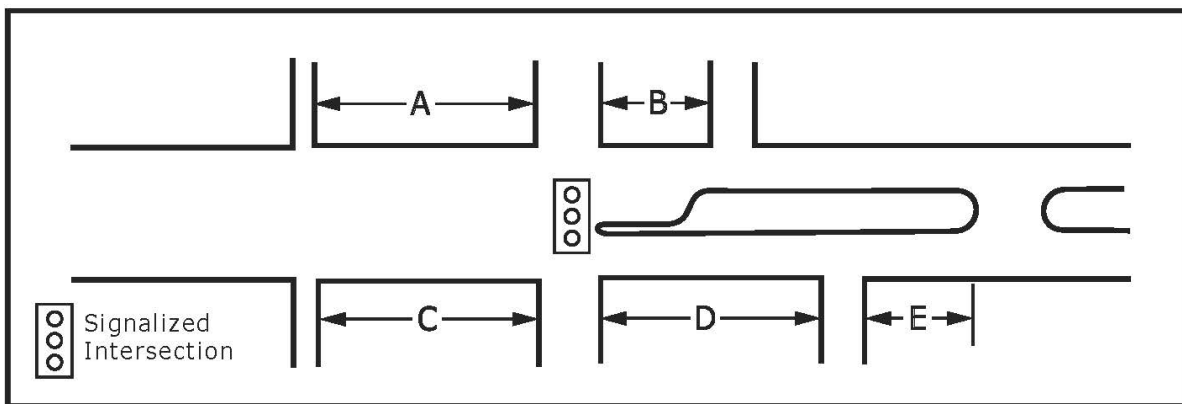

Figure 7.6: Minimum Corner Clearances

7.9.5 DRIVEWAY LOCATION RESTRICTIONS

If a property has frontage on more than one street, access will be permitted only on those street frontages where standards contained in this manual and other Regulations can be met.

Driveways shall not overlap or conflict with the location of a pedestrian curb ramp. Driveways shall not be located at a pedestrian roadway crossing.

Listed below are conditions where a new or proposed change to an existing driveway location will not be permitted.

- A. Within 10 feet of any commercial property line, except when it is a joint-use driveway serving two abutting commercial properties and access agreements have been exchanged between the two abutting property owners;
- B. Within 25 feet of a guardrail terminal;
- C. Within 100 feet of a bridge or other structure, except canal service roads;
- D. When adequate sight distance cannot be provided for vehicles on the driveway attempting to access the street, those movements shall be prohibited. When the nearest edge of any driveway, driveway flare, or driveway radius has less than 2 feet of clearance from the nearest projection of a fire hydrant, utility pole, curb inlet, traffic signal, or light standard;
- E. Residential Driveways: Access shall not be given to any roadway other than local streets. Access shall not be located closer than 150 feet from any collector or arterial street intersection when measured from the intersection of the abutting street right-of-way extended at an intersection and the center of a proposed access point. Exemptions to this requirement may be provided at the discretion of the City Engineer.

7.8.1 VARIANCES

Exceptions may be made by the City Engineer where the application of these standards would create an undue hardship to the abutting property owners and good traffic management practice can be maintained.

7.10 DRIVEWAY STORAGE

The design of a driveway should take into consideration the space necessary to store vehicles using the driveway. This applies to both vehicles making a left turn from the roadway and to vehicles stopped on the driveway waiting to enter the roadway. Adequate storage area is necessary to provide safe and efficient movement of vehicles and pedestrians on the public right-of-way. Examples of on-site storage requirements are shown in Table - 7.5. All anticipated traffic entering a facility will need to be accommodated on-site so that no entering traffic is queuing onto any public roadway.

TABLE 7.5: VEHICLE STORAGE REQUIREMENTS	
Type Of Facility	Recommended Minimum Vehicle Storage³
Drive-in Bank	8 spaces per window ¹
Drive-in Eating and Drinking Establishments	12 spaces per window ²
Automatic Car Wash	7 spaces per wash line
Self-service Car Wash	3 spaces per wash line
Security Check-in	
a. Residential	3 spaces minimum, 1 space per 50 residences, maximum of 10 spaces
b. RV Park	a. 100 ft. for 0-20 RV sites b. 150 ft. for 20-40 RV sites c. 200 ft. for greater than 40 sites
c. Industrial	Based on traffic impact study
Charter Schools	0.15 spaces per student
Drive-in Liquor Store	3 spaces per window ²
Drive-in Dry Cleaners	3 spaces per window ²

- 1 A maximum of 30 spaces will be required for banks with more than 5 drive up windows.
- 2 Measured from the pick-up window, a shorter stacking distance may be permitted by the City Engineer at the recommendations of the development's TIA.
- 3 Measured from point of service to the right of way line for incoming traffic.
- 4 Drive through facilities not listed in the table above shall be evaluated on a case-by-case basis. A TIA may be required by the City to make a determination on the stacking distance.

Examples in Table 7.5 summarize the vehicle storage area requirements to be provided for various uses. These storage areas are:

- A. Based on a space size of 12 feet (width) by 20 feet (length).
- B. Separated from normal parking circulation aisles.
- C. Designed using the appropriate design vehicle turning template.

The vehicle storage area needed for the entire site may be spread over several accesses if more than one access serves the site. The recommended distance may be further adjusted by The City for accesses with two approach lanes and will be subject to traffic volumes and site layout.

When a development is located adjacent to a public road, the parking facility must have full internal vehicular circulation and storage. Vehicular circulation must be located completely within the property and vehicles within one portion of the development must have access to all other portions without using the adjacent road system.

7.11 AUXILIARY LANES FOR DRIVEWAYS

Acceleration and/or deceleration lanes may be required at driveways to assist traffic entering or exiting the roadway.

7.11.1 RIGHT TURN LANES

A driveway right turn deceleration lane is required when either of the following is met:

- A. The outside lane has an expected volume of 250 vph or greater and the right turn volume is greater than 55 vph.
- B. Any three of the below criteria are met:
 1. At least 5,000 vehicle per day are using or are expected to be using the adjacent street.
 2. The roadway’s posted speed limit is 35 mph or greater.
 3. At least 1,000 vehicles per day are using or are expected to use the driveway.
 4. At least 30 vehicles are expected to make right-turns into the driveway within a one-hour period.

For large industrial or commercial developments with a significant percentage of truck traffic entering the site from a high-volume arterial, driveway right turn deceleration lanes may be required at below the above-described criteria and will be evaluated on a case-by-case basis.

7.11.2 LEFT TURN LANES

Volume warrants for adding a left turn lane to either an arterial or collector roadway are shown in Table 7.6. The volumes provided in Table 7.6 are the minimum left turn peak hour volume and minimum through volume in the same direction. A left turn lane will be required if the left turn peak hour volume is equal to or greater than the volume shown in Table 7.6.

TABLE 7.6: VOLUME WARRANTS FOR LEFT-TURN LANES				
Peak Hour Traffic Volume on the Roadway in the Advancing Direction	Minimum Peak Hour Left-turn Traffic Volume			
	# of through lanes per direction			
	1		2	
	< 45 MPH Posted Speed	≥ 45 MPH Posted Speed	< 45 MPH Posted Speed	≥ 45 MPH Posted Speed
≤ 200	30	15	-	-
201-300	12	12	40	30
301-400	12	12	30	25
401-500	12	12	25	18
501-600	12	12	15	12
601-1000	12	12	10	8
1001+	12	8	10	8

7.11.3 ACCELERATION LANES

Acceleration lanes are required when high traffic volume on the road and lack of gaps in traffic makes use of an acceleration lane necessary for vehicles to enter the roadway traffic flow through the use of merging techniques. The City may require an acceleration lane for public safety and traffic operations based on site specific conditions where the posted speed is less than 35 mph. Acceleration lane length shall be designed per AASHTO and/or ADOT criteria.

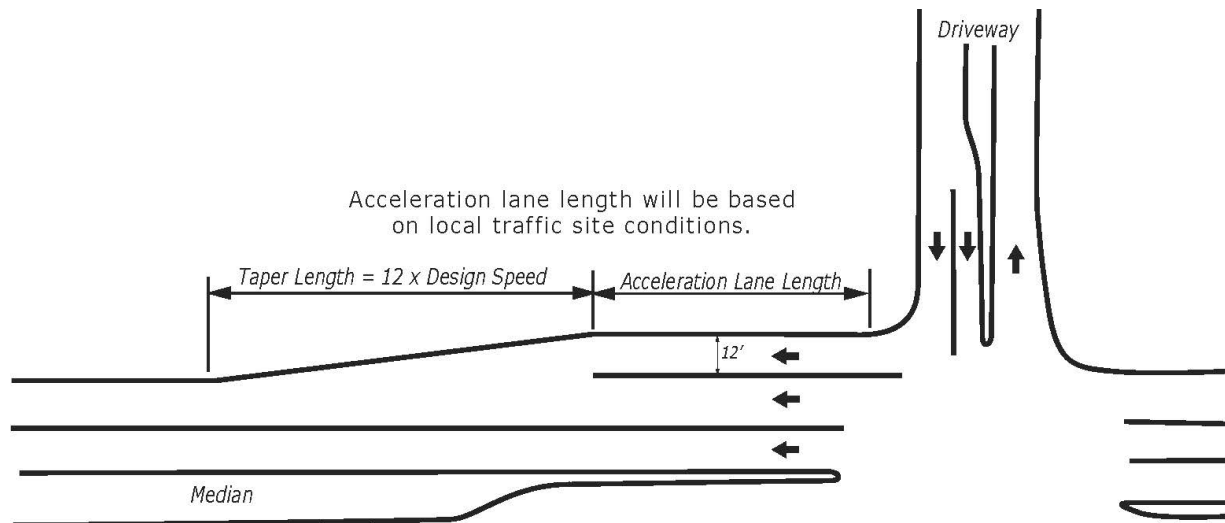

Figure 7.7: Right-Turn Acceleration Lanes

7.11.4 GENERAL SPEED CHANGE, LANE CRITERIA

The general criteria shall apply to right and left turn lanes and acceleration lanes.

- A. When traffic safety so requires, due to specific site conditions such as sight distance, a speed change lane may be required even though the criteria as described in this section are not met.
- B. Where there are three or more through lanes in the direction of travel, the requirement for right turn acceleration and deceleration lanes may be dropped. Each case will be reviewed by the City Engineer, or an authorized representative and a decision made based upon site specific conditions. Generally, lanes will be required only when a high-volume access or a specific geometric safety problem exists.
- C. When calculating the peak hour volume in the outside lane, it will be assumed that all through lanes have equal volumes.
- D. Geometrics for auxiliary turn lanes shall be as shown in Chapter 6.

Chapter 8 Design Guidelines for Bicycle Facilities

8.1 BASIC CRITERIA

8.1.1 GENERAL

Bicycle lanes are included as part of the standard cross section except for local streets as shown in Chapter 5: Geometric Design Standards. Local streets provide extra lane width to facilitate the sharing of the road between bicyclists and motorists.

8.1.2 DEVELOPMENT OF PLANS AND SPECIFICATIONS

Design, design details, and materials shall be in accordance with the current editions of the following publications:

- A. Guide for the Development of Bicycle Facilities, The American Association of State Highway and Transportation Officials, ("AASHTO").
- B. Manual on Uniform Traffic Control Devices (MUTCD), U.S. Department of Transportation, as amended and approved by the Arizona Department of Transportation.
- C. Urban Bikeway Design Guide, National Association of City Transportation Officials (NACTO)

8.1.3 DESIGN EXCEPTIONS

Design exception requests shall follow the procedures given in Section 1.1.

8.2 ROADWAY FACILITY DESIGN GUIDELINES

8.2.1 PAVEMENT SURFACE

- A. Pavement surfaces shall be designed free from irregularities and the edges of the pavement shall be uniform in width.
- B. Roads that are expected to have bicycle traffic shall not have "rumble strips."
- C. When chip sealing is used to recondition roadway surfaces, the cover material shall limit the maximum stone size to $\frac{3}{8}$ " on Bicycle lanes and shoulders.

8.2.2 DRAINAGE GRATES AND UTILITY COVERS

- A. When a new roadway is designed, all drainage grates and utility covers should be kept out of the bicyclists' expected path.
- B. Drainage grates and utility covers shall be adjusted flush with the pavement surface on all

new construction and reconstruction.

- C. On new construction where bicyclists will be permitted, curb inlets rather than drainage grates should be used wherever possible.
- D. Bicycle safe drainage grates shall be used on all roadways.

8.2.3 RAILROAD CROSSINGS

- A. Railroad-highway grade crossings should ideally be at a right angle to the rails.
- B. Pavement surfaces at railroad crossings shall be designed, constructed, and maintained to permit safe, smooth crossings for all roadway users. If the crossing angle is less than approximately 45 degrees, consideration should be given to widening the outside lane, shoulder, or bicycle lane to allow bicyclists adequate room to cross the tracks at a right angle. Where this is not possible, commercially available compressed flange-way fillers can enhance bicyclists' safety. If cost is a factor, these need only be installed across the Bicycle lane portion of the total pavement width.
- C. Warning signs and pavement markings shall be installed in accordance with the Manual on Uniform Traffic Control Devices.

8.2.4 ADDITIONAL ROADWAY HAZARDS

- A. Smooth transitions should exist at all cattle guards, gutters, manholes, and all cut and patch sites on roadways.
- B. Raised pavement markings shall not be used directly along designated bicycle facilities.

8.2.5 BRIDGE TREATMENTS

Bridge crossings shall incorporate facilities that will accommodate all traffic modes that exist or are planned on the roadways to and from the bridge. The design of roadway widths for bridges shall allow on-road Bicycle lanes to be continuous across the bridge.

8.2.6 TRAFFIC CONTROL DEVICES

- A. Bicyclists should be taken into consideration in the timing of traffic signals and in the placement of traffic detection devices.
- B. Where programmed visibility signal heads are used, they shall be checked to ensure that they are visible to a bicyclist who is properly positioned on the road.
- C. The Manual on Uniform Traffic Control Devices should be consulted for guidance on signs and pavement markings.

8.2.7 BICYCLE ROUTES

Signing of Bicycle route shall be in accordance with the Manual on Uniform Traffic Control Devices.

8.2.8 PAVED SHOULDERS

The designation of paved shoulders as Bicycle lanes or Bicycle routes shall be a decision made by the City Engineer.

8.2.9 BICYCLE LANES

- A. Bicycle lanes shall always be one-way facilities that carry traffic in the same direction as the adjacent motor vehicle lane. Two-way bicycle lanes on one side of the roadway are unacceptable.
- B. Bicycle lanes on one-way streets shall be placed on the right edge of the road, except in areas where placement on the left will significantly reduce conflict.
- C. The minimum bicycle lane width on urban (curbed) roadways where parking is prohibited shall be 4.5 feet, measured from the edge of the vehicle lane to the longitudinal joint between the roadway surface and the gutter pan. When the gutter pan is less than 12 inches in width, the minimum distance from the edge of the vehicle lane to the face of curb shall be 6 feet.
- D. The minimum bicycle lane width on non-curbed streets with no parking is 6 feet of useable pavement width.
- E. The minimum bicycle lane striped width for a curbed street where a parking lane is provided is 5 feet to the left of a minimum 10-foot wide parking area. Bicycle lanes shall always be placed between the parking lane and the through traffic lane. If the parking volume is substantial or turnover is high, an additional 1 or 2 feet of width is recommended for safe bicycle operation.

8.3 SHARED USE PATH DESIGN GUIDELINES

8.3.1 GENERAL

- A. Shared use paths shall be designed to accommodate all expected users. These users may include but are not limited to pedestrians, bicyclists, and equestrians.
- B. Shared use paths are to minimize crossing by motor vehicles.
- C. On- and off-street bicycle facilities are to complement and connect with each other.
- D. Design shall comply with the most recent edition of the following:
 - 1. Americans with Disabilities Act (ADA) design standards,
 - 2. AASHTO Guide for the Development of Bicycle Facilities,
 - 3. Design guidelines from FHWA, and other nationally recognized organizations approved by the City Engineer.
- E. Standard sidewalk widths do not constitute an acceptable shared use path or bicycle facility.

8.3.2 SHARED USE PATH WIDTH AND CLEARANCE DISTANCES

- A. The minimum width for a paved shared use path is ten feet. Twelve feet is recommended where high use is expected.
 - 1. Paths may be reduced to 8 feet wide due to site limitations and conditions which shall be determined by the City Engineer.
- B. A minimum two-foot-wide stabilized surface area shall be provided adjacent to both sides of pathway pavements. This area shall remain free from obstructions and serve as a two-foot clear zone and be included within the designated right-of-way.
- C. The shared use path vertical clear distance shall be ten feet minimum.
- D. Shared use paths adjacent to streets or roadways must be separated by at least five feet from the back of curb unless a barrier is provided. Separations may be reduced due to site limitations and conditions which shall be determined by the City Engineer.
- E. One-way shared use paths are not acceptable.
- F. Accessible ramps should be the same width as the shared use path.

8.3.3 SHARED USE PATH DESIGN SPEED

The minimum design speed for paved shared use paths is 18 mph. In areas with hilly terrain and sustained steep grades (six percent or greater) the appropriate design speed should be selected based on the anticipated travel speeds of bicyclists going downhill. In all but the most extreme cases, 30 mph should be the maximum design speed.

8.3.4 SHARED USE PATH HORIZONTAL ALIGNMENT AND SUPERELEVATION

- A. The maximum superelevation rate is two percent (2%).
- B. The minimum design radius of curvature shall be derived from the formulas and figures provided in the AASHTO Guide for the Development of Bicycle Facilities.

8.3.5 SHARED USE PATH GRADES

Grades greater than 5 percent are not recommended. Where the terrain dictates, grades over 5 percent may be allowed for short distances. Refer to the ADA Standards of Accessible Design and AASHTO Guide for the Development of Bicycle Facilities for specific grade restrictions and grade lengths.

8.3.6 SHARED USE PATH SIGHT DISTANCES

The minimum sight distance shall be derived from figures and formulas contained in the AASHTO Guide for the Development of Bicycle Facilities.

8.3.7 SHARED USE PATH INTERSECTIONS

- A. The number of path and roadway /driveway intersections should be minimized.
- B. Right-of-way shall include areas required for adequate sight distance for turning movements.
- C. Shared use path intersections and approaches shall be on as flat of a grade as practical. Intersection grades shall not exceed two percent (2%).
- D. For traffic control devices, application of the Manual on Uniform Traffic Control Devices warrant criteria shall be used (signal, stop sign, yield sign, etc.).
- E. Sign type, size, and location shall be in accordance with guidance provided in the Manual on Uniform Traffic Control Devices.

8.3.8 SHARED USE PATH SIGNING AND MARKING

Uniform application of traffic control devices (signs and markings), are described in the Manual on Uniform Traffic Control Devices. A 4-inch wide yellow centerline stripe shall be used to separate opposite directions of travel along paved shared use paths under the following circumstances:

- A. For heavy volumes of bicycles,
- B. On curves with a restricted sight distance,
- C. On unlit paths

8.3.9 SHARED USE PATH SURFACING

- A. Paved shared use paths shall be constructed of either asphalt concrete or Portland cement concrete. A pavement design report prepared and sealed by a Professional Engineer shall be submitted to The City.
- B. Pavements are to be designed to sustain, without damage, wheel loads of emergency, patrol, maintenance, and other motor vehicles that are expected to use or cross the path.
- C. Pavements for shared use paths shall provide a smooth and consistent surface. Skid resistance qualities shall not be sacrificed for the sake of smoothness.

8.3.10 SHARED USE PATH LIGHTING

- A. For illuminated paths an average maintained horizontal illumination level of 0.5 foot-candle to 2 foot-candles is recommended.
- B. Light standards (poles) shall meet the recommended horizontal and vertical clearances.
- C. Meet the lighting requirements in section 151.11 of the City of Sierra Vista Development Code.

8.3.11 SHARED USE PATH DRAINAGE

- A. A standard surface cross slope of 1½% shall be provided.
- B. One-way slopes shall be used. Crowned pathways shall not be permitted.
- C. Provide drainage facilities that will prevent concentrate flows from flowing across the pathway pavement and to prevent ponding on the pavement.
- D. Locate manhole covers and drainage grates away from the pathway pavement where practical.

8.3.12 SHARED USE PATH RESTRICTION OF MOTOR VEHICLES

Removable bollard posts or other approved devices may be used to restrict unauthorized access to paths. Bollard posts shall be permanently reflectorized for nighttime visibility and painted a bright color for daytime visibility. Provide clear five-foot pathway openings between bollards and other restrictions. 

Chapter 9 Landscaping

9.1 LANDSCAPE DESIGN

9.1.1 PURPOSE

These Landscape Design Standards have been written to serve as a guide to landscape architects and highway engineers for the purpose of designing and reviewing roadway landscaping plans.

9.1.2 DESIGN CONSIDERATIONS

The surroundings in which the roadway is being designed will have a strong influence on the landscape design. The design shall be respectful of existing natural features such as landforms and vegetation. When the roadway traverses urban developed areas, the landscape design shall reinforce the adjacent landscape theme or character. The principles of low maintenance and low water use shall be incorporated into all landscape designs.

Under no circumstances shall the landscape design compromise the safety of roadway users: motorists, pedestrians, bicyclists, and maintenance workers.

Many elements need to be considered during development of the landscape design. The landscape design process shall begin with a thorough inventory and analysis of existing conditions, including: the natural landscape elements, topographic and physical characteristics, ecological factors, recreational potentials, residential qualities, historical features and visual values.

9.2 DESIGN CRITERIA

9.2.1 SIGHT DISTANCES, SIGHT LINES, AND SIGHT TRIANGLES

When designing landscaping along roadways and near intersections and driveways, placement and height restrictions for plants and landscaping materials shall be observed. The purpose of these restrictions is to provide drivers with a clear view of signs and roadway conditions, allowing vehicles to turn safely at driveways and intersections.

Intersection and driveway departure sight triangles shall be maintained clear of sight obstructions. Sight triangle dimensions are influenced by roadway classification, vehicle speed, terrain, and vehicle type. Roadway classifications are as designated by City. Intersection Sight Distance is calculated using the roadway design speed and the time gap for the vehicle type shown in Table 9.2. Driveway Sight Distance is calculated using the roadway posted speed modified as indicated in section 7.7.5 and the time gap for the vehicle type indicated in Table 9.2. Departure sight triangles shall be shown, dimensioned, and labeled on the landscape plans, see Figure 9.2. The sight distances A (to the right) and B (to the left) are calculated from the formula $D = 1.47 V_{\text{major}} t_g$. The values for t_g are determined as identified in the AASHTO publication *A Policy on Geometric Design of Highways and Streets*. When requested, profiles along sight lines shall be submitted for review.

TABLE 9.2 Vehicle Type for Determining Departure Sight Triangles				
Major Road Classification	Minor Road Classification	Vehicle 1		
		Right Turn	Left Turn	Cross
Arterial	Arterial	Combination Truck	Combination Truck	Single Unit Truck
Arterial	Collector	Single Unit Truck	Single Unit Truck	Single Unit Truck
Arterial	Local	Single Unit Truck	Single Unit Truck	Single Unit Truck
Arterial	Commercial Industrial Driveway	Combination Truck	Combination Truck	-----
Arterial	Residential Driveway	Passenger Car	Passenger Car	-----
Collector	Collector	Single Unit Truck	Single Unit Truck	Single Unit Truck
Collector	Local	Single Unit Truck	Single Unit Truck	Single Unit Truck
Collector	Commercial Industrial Driveway	Single Unit Truck	Single Unit Truck	-----
Collector	Residential Driveway	Passenger Car	Passenger Car	-----
Local	Local	Single Unit Truck	Single Unit Truck	Single Unit Truck
Residential Subdivision Local	Residential Subdivision Local	Passenger Car	Passenger Car	Passenger Car
Local	Commercial Industrial Driveway	Single Unit Truck	Single Unit Truck	-----
Local	Residential Driveway	Passenger Car	Passenger Car	-----

- INTERSECTION DEPARTURE SIGHT TRIANGLES

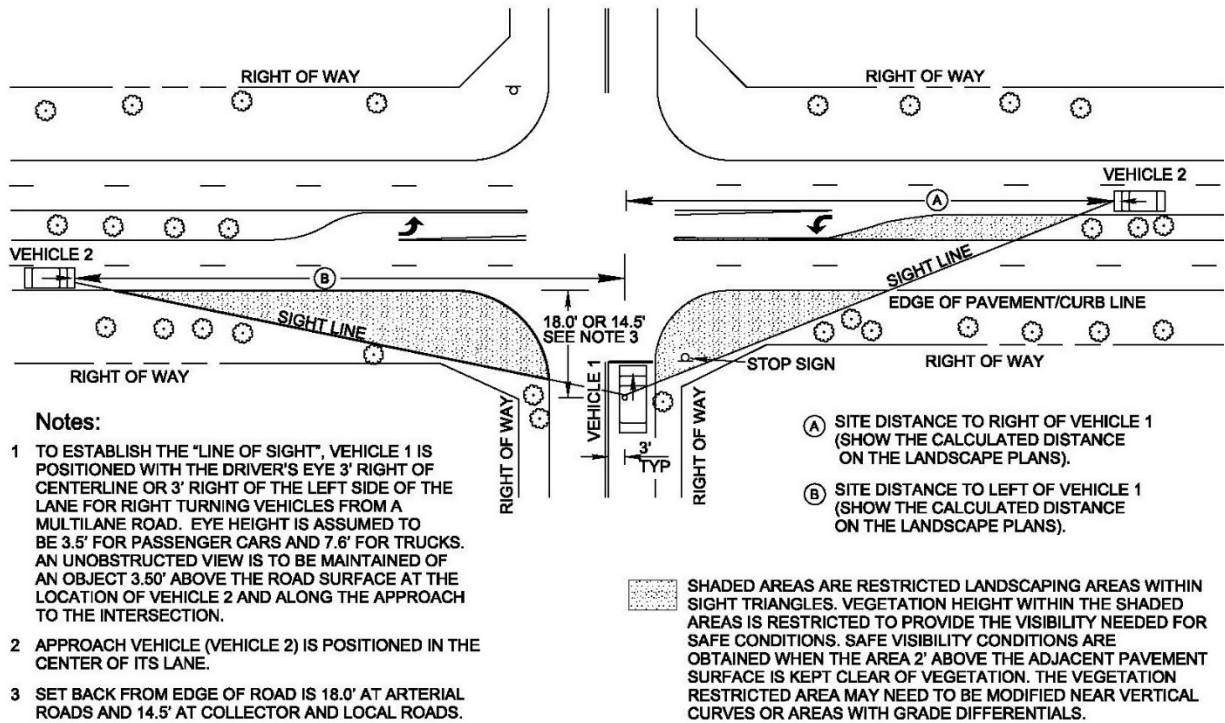

Figure 9.2A Sight Distance Triangle General

- DEPARTURE SIGHT TRIANGLES FOR PASSENGER CARS

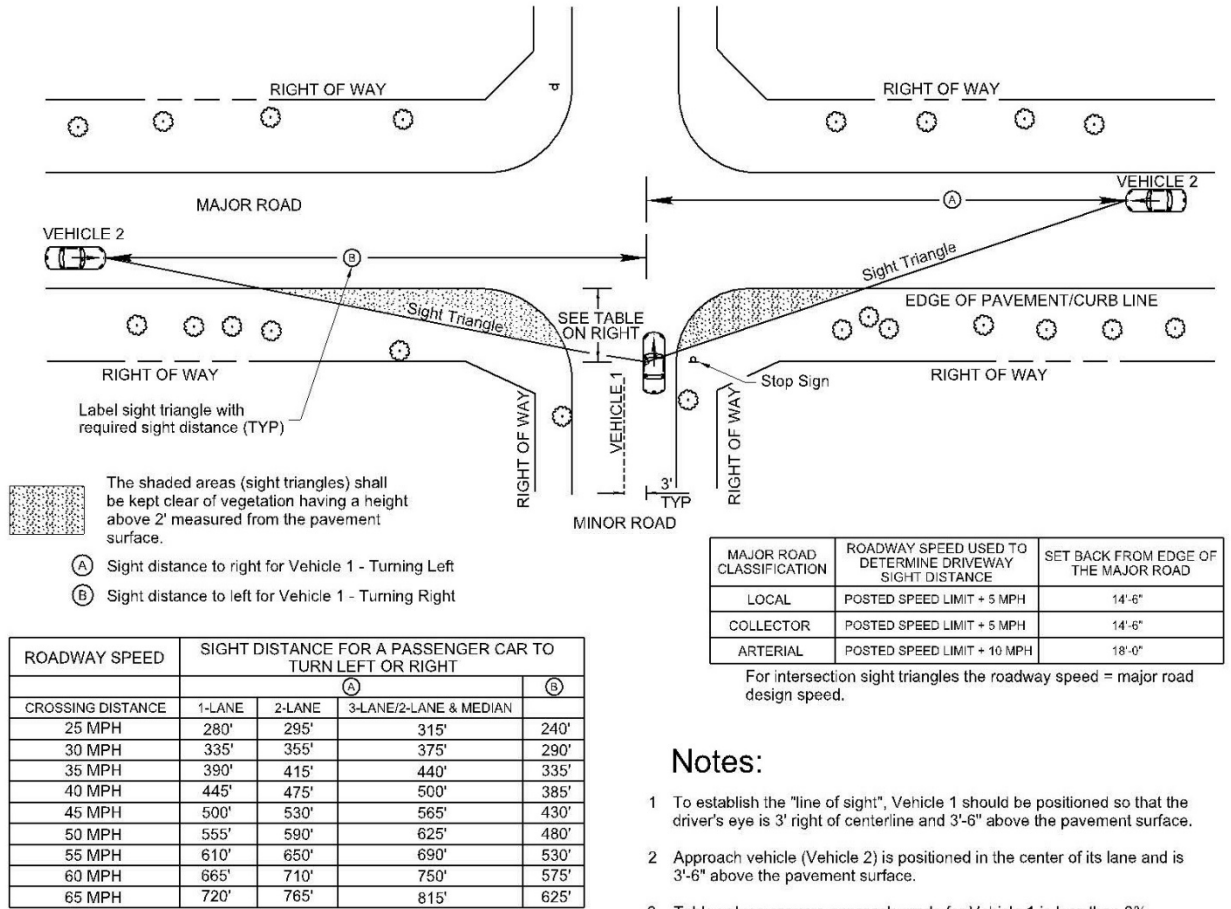
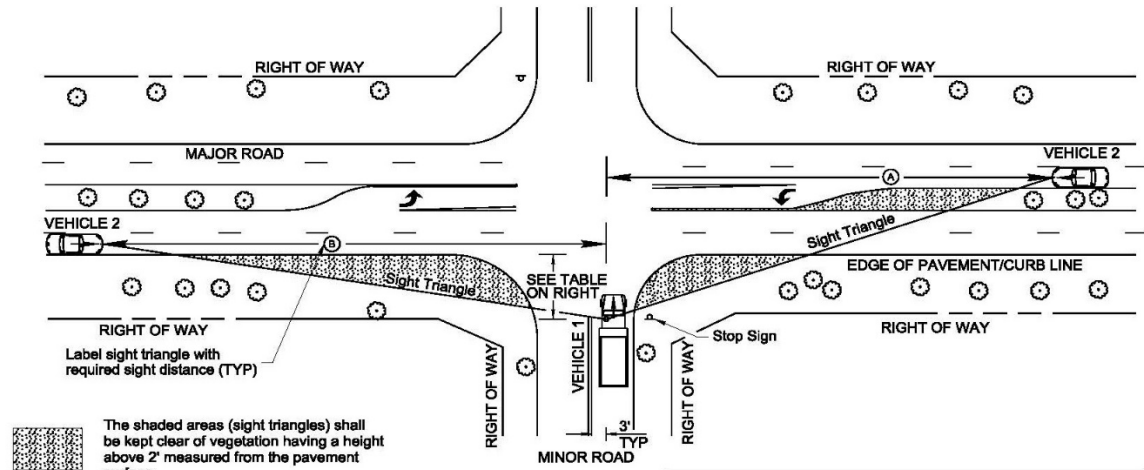

Figure 9.2B Sight Distance Triangle Passenger Cars

- DEPARTURE SIGHT TRIANGLES FOR SINGLE UNIT TRUCKS



- (A) Sight distance to right for Vehicle 1 - Turning Left
- (B) Sight distance to left for Vehicle 1 - Turning Right

ROADWAY SPEED	SIGHT DISTANCE FOR A SINGLE UNIT TRUCK TO TURN LEFT OR RIGHT				
	(A)			(B)	
CROSSING DISTANCE	1-LANE	2-LANE	3-LANE/2-LANE & MEDIAN	3-LANE & MEDIAN	
25 MPH	350'	375'	405'	430'	315'
30 MPH	420'	450'	485'	515'	375'
35 MPH	490'	525'	565'	600'	440'
40 MPH	560'	600'	645'	685'	500'
45 MPH	630'	675'	725'	770'	565'
50 MPH	700'	750'	805'	855'	625'
55 MPH	770'	825'	885'	940'	690'
60 MPH	840'	900'	965'	1,025'	750'
65 MPH	910'	975'	1,045'	1,110'	815'

MAJOR ROAD CLASSIFICATION	ROADWAY SPEED USED TO DETERMINE DRIVEWAY SIGHT DISTANCE	SET BACK FROM EDGE OF THE MAJOR ROAD
LOCAL	POSTED SPEED LIMIT + 5 MPH	14'-6"
COLLECTOR	POSTED SPEED LIMIT + 5 MPH	14'-6"
ARTERIAL	POSTED SPEED LIMIT + 10 MPH	18'-0"

For intersection sight triangles the roadway speed = major road design speed.

Notes:

- 1 To establish the "line of sight", Vehicle 1 should be positioned so that the driver's eye is 3' right of centerline and 7'-7" above the pavement surface.
- 2 Approach vehicle (Vehicle 2) is positioned in the center of its lane and is 3'-6" above the pavement surface.
- 3 Table values assume approach grade for Vehicle 1 is less than 3%.

Figure 9.2C Sight Distance Triangle Single Unit Trucks

DEPARTURE SIGHT TRIANGLES FOR COMBINATION TRUCKS

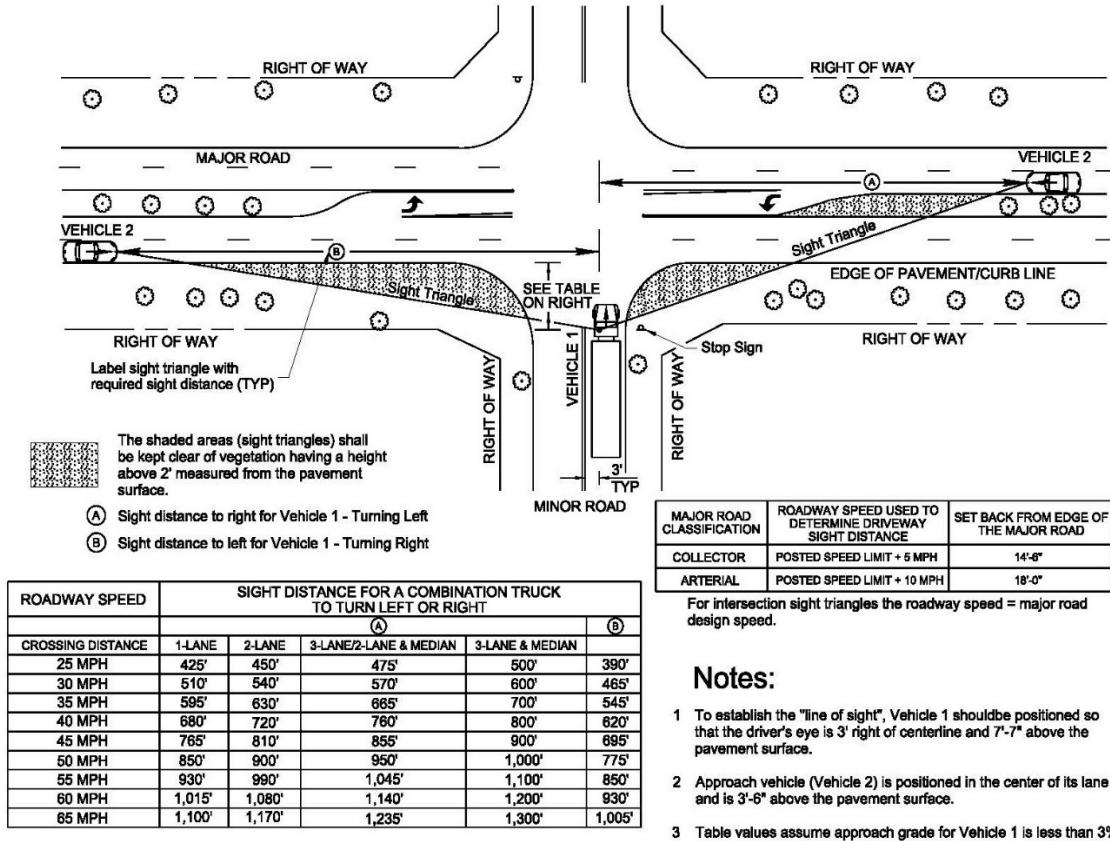

Figure 9.2.C Sight Distance Triangle Combination Trucks

9.3 LANDSCAPE MAINTENANCE GENERAL

9.3.1 RELATED DOCUMENTS

The General Provisions of the Contract, including all General and Supplementary Conditions apply to the work specified in this Section.

9.3.2 DESCRIPTIONS OF WORK

The work covered by this Section includes, but is not limited to the following:

- Acquisition of required permits and requests for required inspections.
- Protection of existing improvements.
- Installation of plants and staking of trees.
- Subgrade preparation, installation of decompose granite, and applying pre-emergent.
- Protection of completed work.
- Clean-up.
- Initial maintenance of landscape improvements.
- Plant material guarantee.

9.3.3 RELATED WORK

Related work includes but is not limited to: The installation and testing of an automatic irrigation system.

9.3.4 COORDINATION

The Contractor shall coordinate all landscape work with the City of Sierra Vista's designated representative. Work by other that is completed, or in-progress shall be protected during the installation of the landscape improvements.

9.3.5 REQUIRED LICENSURE

All landscape work shall be performed by a Contractor licensed by the State of Arizona Registrar of Contractors. The commercial license classification held by the Contractor shall be appropriate for the work to be performed.

9.3.6 PRE-CONSTRUCTION CONFERENCE

Prior to commencing work on the project, the Contractor shall participate in an on-site conference with the City. The conference shall be attended by the Contractor's Project Manager and Field Superintendent.

9.3.7 INSPECTION OF SITE CONDITIONS

The Contractor shall examine the existing site conditions prior to starting the work specified in this Section. The Contractor shall report to the City, in writing, conditions, which will prevent proper implementation of the work. Beginning work of this Section without reporting unsuitable conditions to the City shall constitute acceptance of the existing conditions by Contractor. All required removal, repair, or replacement work resulting from these existing conditions shall be performed at no additional cost to the City.

Reference Data: Maps, soil investigation reports, and similar reference data provided by the City to the Contractor are for information only. The City assumes no responsibility for any conclusions drawn there from. The Contractor shall examine the site and shall determine the existing conditions, under which work shall be performed, including subsurface conditions.

9.3.8 SUBMITTALS AND APPROVALS

The Contractor shall make the following submittals. No material shall be delivered to the site or incorporated into the work until the submittals have been approved, in writing, by the City.

- A. Samples: Decomposed Granite: a one cubic foot sample of the same source, gradation, and color as proposed for use on the project.
- B. Certificate of Analysis: Prepared Soils material: Three (3) copies of a certificate, signed by the material supplier, indicating that the materials used in the preparation of the prepared soil to be used on the project complies with the project specifications.

9.3.9 STORAGE OF MATERIALS

- A. General: The Contractor's equipment and materials shall only be stored in on-site locations approved by the City.
- B. Fertilizers: Chemical fertilizers shall be stored in a weatherproof storage area.

9.3.10 PERMITS AND INSPECTIONS

The contractor shall obtain and pay for all permits and inspections required by governing agencies.

9.3.11 STRUCTURES

The Contractor shall protect from damage during the performance of the work specified in this Section, all structures and other improvements as shown, scheduled, and required to remain on the site. The Contractor shall repair all damage resulting from negligence by the Contractor. Repair or replacement work shall be performed by the Contractor, as approved by the City, at no additional cost to the City. The Contractor shall notify City of any uncertainty or conflicts regarding requirements of this Section and existing site conditions.

9.3.12 UTILITIES

- A. Blue-Staking: The Contractor shall have the project site Blue-Staked prior to the start of the Landscape Work and shall keep the Blue-Staking current during the course of the project. All damage to existing utilities shall be repaired by the Contractor, as directed by the applicable utility company, at no cost to the Owner.
- B. Unmarked Utilities: The Contractor shall notify the City of all other utility lines as may be encountered during the execution of the work. The Contractor shall not proceed without instructions from the City, except to correct an immediate hazard or emergency condition.

9.4 LANDSCAPE MAINTENANCE MATERIALS

9.4.1 PLANT MATERIALS

- A. Plant Material Standards: All plants used on the project shall meet the applicable requirements of the following:

The Arizona Nursery Association Grower's Committee "Recommended Tree Specifications."
The American Association of Nurserymen "American Standard for Nursery Stock" (ANSI Z60.1-1990)

Where discrepancies occur between these standards, and the project plans and specifications, the most stringent requirements shall apply.

- B. General Plant Requirements:

- 1. All plants shall be hardy under the climate conditions similar to those found on the project.

Sierra Vista Modified Maricopa County Roadway Design Manual

2. All plants shall be typical of their species or variety and shall have a normal habit of growth. They shall be sound, healthy, vigorous, well-branched, and densely foliated when in leaf. They shall be free from disease and insect pests, eggs, or larvae. They shall have healthy, well-developed root systems.
- C. Container grown stock shall have been grown in a container long enough for the root system to have developed sufficiently to hold the soil together within the root ball. Root bound plants, plants with excessive root growth relative to the container size, will not be accepted.
- D. Plant Species and Quantities:
1. The Contractor shall furnish all plants shown on the drawings or specified in the quantities listed on the plant materials list or as shown on the Project Plans.
 2. The quantity, size, species, scientific and common names and manner in which plants are to be furnished are shown on the planting plans and schedules. In instances where there is a discrepancy between the quantity shown on the plant list or landscape schedule and the actual quantity shown on the planting plan, the planting plan quantity shall govern.
- E. Substitution
1. When plants of the specified species, size, and variety are not reasonably available, as determined by the City, substitutions recommended by the Contractor will be considered. No substitution may be made without the written approval of the City. Substitute plants shall be of equal or greater size than the plant originally specified.
- F. Inspections and Acceptance of Plant Material
1. Plants are subject to inspection and approval, at the place of growth or upon delivery to the project site, for conformity to specification requirements as to quality, size, and variety. Such approval shall not impair the City's right to inspect plants during the progress of work or the City's right to reject plants due to damage suffered in handling or transportation. Rejected plants shall be immediately removed from the site by the Contractor.

9.4.2 SOIL MATERIALS AND AMENDMENTS

- A. Native Soil: Native soil shall be the on-site soil.
- B. Forest Mulch: Forest Mulch shall consist of composed, ground, or shredded fir or ponderosa pine bark shavings with at least 85% able to pass through a 1/4" screen. The pH shall not exceed 7.5. The mulch shall be hydrgroscopic or contain a wetting agent and shall be nitrogen stabilized with a 0.5 percent nitrogen content.

9.4.3 PREPARED SOIL FOR TREES AND SHRUBS

- A. Prepared Soil Mix for Trees and Shrubs: Prepared mix shall consist of 2 parts on-site native soil and one part Forest Mulch.
- B. Each planting pit shall receive fertilizer tablets (21 gram Agriform, 20-10-5) at a rate of one per 1 gallon, two per 5 gallon, four per 15 gallon, and eight per 24" and 36" box containers.

9.4.4 PRE-EMERGENT HERBICIDE

- A. Pre-Emergent Herbicide: Pre-emergent herbicide shall be “Sureguard” or approved equal.

9.4.5 DECOMPOSED GRANITE MATERIAL

- A. General Requirements: Decomposed Granite shall be free of foreign materials and particles over ½” in diameter, for landscaped areas and stabilized decomposed granite areas. The Contractor shall submit samples to the City for approval of color and gradation. All material shall be from a single source and shall present a uniform appearance.
- B. Gradation: The decomposed granite material shall comply with the following gradation:

For Landscaped Areas

Sieve Size	Percent Passing
3/4"	100%
1/2"	80 - 100%
No. 40	35-60 %

9.4.6 STABILIZER MATERIAL

- A. Stabilizer for Decomposed Granite: Stabilizer shall be as manufactured by Stabilizer Inc., 4382 East Indian School Road, Phoenix, Arizona. (1-800-336-2468). The stabilizer shall be mixed with the decomposed granite material off-site.

9.4.7 TREE STAKING MATERIALS

- A. Tree stakes shall be 7' long for 15-gallon trees and 10' long for 24" box trees, galvanized U-channel signposts, rated at 2 lbs per foot.
- B. Wire and hose shall conform to the Project Plan and Construction Details.

9.5 LANDSCAPE MAINTENANCE EXECUTION

9.5.1 PLANTING SEASON

Trees, shrubs, and other plants may be planted at any time consistent with the overall schedule for project completion. Plants installed during windy, hot, or cold periods shall be at the Contractor’s risk. Plants which die as a result of weather conditions immediately following planting shall be replaced by the Contractor at no cost to the City.

9.5.2 LAYOUT AND STAKING OF PLANT LOCATIONS

- A. Prior to the start of planting work in each project area and prior to the installation of irrigation laterals, the Contractor shall stake out the locations of all plant material. Each stake shall be clearly marked or coded to indicate the type and size of the plant to be installed.

- B. No plant material shall be installed until all proposed locations are inspected and approved by the City.

9.5.3 PLANT INSTALLATION

- A. Soil used in planting shall be prepared soil as specified.
- B. All hardpan, caliche, and rubble excavated from plant pits shall be disposed of off the site.
- C. Excavations for plant material shall be of the size indicated on the Project Plans and Construction Details. Plant pits shall be excavated to the depth specified. If requested by the City, the pits shall be tested for drainage. To test for drainage, the plant pit shall be partially filled with water and the rate of infiltration measured. The minimum rate of infiltration shall be six inches (6") per hour. If drainage is found to be unsatisfactory, a nine-inch diameter drainage hole in the center of the tree pit shall be dug to the depth required to provide for adequate drainage. Testing and drainage holes in up to five percent (5%) of the plant pits shall be made by the Contractor, if requested by the City, at no additional cost to the Owner.
- D. Plants shall be removed from containers immediately before planting in a manner which will not injure the roots or break the root ball. The root ball shall be kept intact during the planting operation. Should the Contractor, in the process of installing a plant, crack the root ball or damage the plant in any way, he shall replace the plant at his expense. All replacement material shall be subject to the approval of the City.
- E. Plants shall be set in the center of the pits, plumb and straight, and at such a level that after settlement, the relationship of the top of the root ball to finished grade is as detailed on the Project Plans.
- F. The prepared soil shall be tamped and/or watered-in as the material is placed. Grades in the vicinity of the plant shall be finished at the time of plant installation. Plants shall be irrigated immediately following installation.

9.5.4 TREE STAKING

- A. Stakes for trees shall be installed in conformance with the Project Plans and Construction Details. Stakes shall be placed outside of the root-balls. It shall be the Contractor's responsibility to restore or repair the staking of any trees that are staked improperly or that break loose from the stakes during the construction period and during the Initial Maintenance Period.
- B. Trees which can stand upright without stakes may be left unstaked if approved, in writing, by the City.

9.5.5 DECOMPOSED GRANITE INSTALLATION IN LANDSCAPED AREAS:

- A. The areas to receive decomposed granite surfacing shall be as designated on the Project Plans.
- B. The procedures used in the installation of the Decomposed Granite shall be as follows:
 - 1. All weeds and debris shall be removed from the designated area.

2. The subgrade shall be fine graded and cleaned to remove rocks and soil clods one inch (1") in diameter or greater.
3. The subgrade shall be treated with pre-emergent herbicide, Sureguard or an approved equal. The application shall be made by an Applicator licensed by the State of Arizona. The application shall be made in accordance with the product label. Copies of all applications sheets and receipts shall be submitted to City.
4. The decomposed granite material shall be placed, graded, and lightly compacted to provide for a minimum depth, after compaction, of two inches (2"). Compaction shall be accomplished by dampening the material and rolling it with a water-filled drum roller. The minimum weight of the roller shall be approximately 100 lbs. per foot of roller width.
5. The surface of the decomposed granite shall be retreated with pre-emergent herbicide, as specified above.

9.5.6 STABILIZED DECOMPOSED GRANITE

A. The procedures used in the installation of the Decomposed Granite shall be as follows:

1. All weeds and debris shall be removed from the designated area.
2. The subgrade shall be excavated as needed and graded.
3. The subgrade shall be treated with pre-emergent herbicide, Sureguard or an approved equal. The application shall be made by an Applicator licensed by the State of Arizona. The application shall be made in accordance with the manufacturer's written instructions and recommendations for field conditions at the time of application.
4. The decomposed granite / stabilizer material shall be placed, graded, watered in, and compacted with a water filled drum roller in accordance with the stabilizer manufacturer's written instructions. The depth of the material, after compaction shall be four inches (4").

9.5.7 FINISHED GRADES

- A. Finished grades, slopes, and drainage patterns in all landscaped areas shall be in conformance with the Project Plans and Details. Finished grades shall be maintained by the Contractor through the end of the Initial Maintenance Period.
- B. Finished grades adjacent to curbs, walks, paths, and other pavements shall be as detailed. Where details are not provided, a reveal of one inch (1") shall be provided.

9.5.8 CLEAN-UP

- A. The Contractor shall be responsible for keeping the project site and work and storage areas neat and clean at all times during the course of the project.

9.5.9 PROTECTION OF COMPLETED WORK

- A. The Contractor shall replace or repair defective landscape work, as determined by City, at no additional cost to the City.
- B. Finished Grades and Surfaces: The Contractor shall protect all finished grades and surfaces within landscaped areas from erosion and other damage. If erosion does occur, the Contractor shall immediately repair, recompact, and resurface the eroded or damaged area. The detailed or

specified reveal between paved surfaces and landscaped areas shall also be maintained by the Contractor.

- C. Weed Control: The entire project area shall be kept in a weed free condition, at no additional cost to the Owner.

9.5.10 CONTRACTOR MAINTENANCE AND ACCEPTANCE OF THE WORK

- A. Maintenance During Construction: During project construction, the Contractor shall maintain the entire project area, which includes, but not be limited to: hydro-seeded areas, decomposed granite areas, graded areas, and excavated areas. Maintenance shall include, but not be limited to: irrigation, fertilization, mowing, pruning, weed control and removal, repair of damaged staking, and repair of damaged or eroded areas. Maintenance during construction shall continue until Initial Acceptance of the Work.
- B. Final Acceptance of the Work: Upon substantial completion of the landscape work, the Contractor shall notify the City who will schedule an inspection of the project. During the inspection, items which are incomplete, or which must be repaired or replaced will be identified. Upon completion or correction of the items noted, the City will issue written notice to the Contractor indicating final Acceptance of the Work. Final Acceptance of the landscape work will be concurrent with the Initial Acceptance of the irrigation work.
- C. Final Warranty Acceptance: Upon completion and acceptance of the final warranty inspection, the City will issue written notice to the Contractor indicating Final Warranty Acceptance. During the inspection, items which are incomplete, or which must be repaired or replaced will be identified. Upon issuance of this notice the City will assume responsibility for project maintenance. Final Warranty Acceptance of the landscape improvements will be concurrent with Final Warranty Acceptance of the irrigation system.
- D. Responsibility for maintenance shall be established during the early design stages. Should a separate entity desire to maintain the landscaping in the right-of-way, a written maintenance agreement or CC&R's shall be developed or provided to the City. Such arrangements will not only prevent jurisdictional problems after construction but may also affect the design of facilities. Documents must state who is responsible for landscape maintenance. In addition, a Letter of Guarantee shall be obtained from the entity assuming future maintenance responsibilities.

9.5.11 GUARANTEE

- A. Plant Materials: The Contractor shall guarantee all plant materials installed as part of this project for a period of one year after Final Acceptance by the City
- B. Plants which die or become diseased during the guarantee period, for reasons other than neglect, Acts-of-God, or causes deliberate, as determined by the City, shall be replaced by the Contractor at no additional cost to the City. Replacements shall be made within 30 days of receipt of notice by the Contractor.
- C. The Contractor shall submit a Letter of Guarantee, as provided by the City, and a monetary security in a form acceptable to the City, covering 110 percent of the landscaping costs, prior to Final Acceptance of the landscaping work. The security shall be returned after approval of the one-year guarantee inspection.

9.6 IRRIGATION SYSTEMS GENERAL

9.6.1 RELATED DOCUMENTS

The General provisions of the Contract, including all General and Supplementary Conditions apply to the work specified in this section.

9.6.2 DESCRIPTION OF WORK

The work covered by this Section includes, but is not limited to, the following:

- A. Acquisition of required permits and requests for required inspections.
- B. Protection of existing improvements.
- C. Coordination of new water meter installation.
- D. Coordination of a new electrical service and meter.
- E. Coordination of a new telephone service.
- F. Trenching for the installation of irrigation pipelines and control wiring.
- G. Installation of PVC pipe and polyethylene tubing.
- H. Installation of valves and other equipment.
- I. Installation of automatic irrigation controller / cluster control unit.
- J. Installation of master valve and related water management equipment.
- K. Connection of the irrigation controller to electrical and telephone services.
- L. Operational and pressure testing of the system.
- M. Preparation of As-Built record drawings.
- N. Clean-up during and at the completion of construction.
- O. Initial maintenance of the irrigation system.
- P. Irrigation System Guarantee.

9.6.3 RELATED WORK

A. Related work includes, but is not, limited to: The installation of trees, shrubs and other landscape improvements.

9.6.4 COORDINATION

The Contractor shall coordinate all irrigation work with the City. Work by others that is completed, or in-progress shall be protected during the installation of the irrigation system.

9.6.5 REQUIRED LICENSURE

All irrigation work shall be performed by a Contractor licensed by the State of Arizona Registrar of Contractors. The commercial license classification held by the Contractor shall be appropriate for the work to be performed.

9.6.6 PRE-CONSTRUCTION CONFERENCE

Prior to commencing work on the project, the Contractor shall participate in an on-site conference with the City. The conference shall be attended by the Contractor's Project Manager and Field Superintendent.

9.6.7 INSPECTION OF SITE CONDITIONS

- A. The Contractor shall examine the existing site conditions prior to starting the work specified in this Section. The Contractor shall report to the City, in writing, conditions which prevent the proper implementation of the work.
- B. Beginning work of this Section without reporting unsuitable conditions to the City shall constitute acceptance of the existing conditions by the Contractor. All removal, repair, or replacement work resulting from these existing conditions shall be performed at no additional cost to the City.
- C. Reference Data: Maps, soil investigation reports, and similar reference data not included in the Contract but made available to the Contractor are for information only. The City assumes no responsibility for any conclusions drawn there from. The Contractor shall examine the site and shall determine the existing conditions, under which the work shall be performed, including subsurface conditions.

9.6.8 SUBMITTALS AND APPROVALS

- A. The Contractor shall make the following submittals. No material shall be delivered to the site or incorporated into the work until the submittals have been approved, in writing, by the City.

- 1. Manufacturer's Specification Sheets:

The Contractor shall submit five (5) bound sets of material and equipment specification sheets for the following items. In each of the submitted sets, the model, size, and other features of the proposed material shall be clearly indicated. Submittals that are incomplete or that do not indicate the features of the proposed equipment will be returned to the Contractor without being reviewed.

- a. Backflow Preventer
 - b. Backflow Preventer Security Enclosure
 - c. Controller / CCU
 - d. Controller Security Enclosure
 - e. PVC Mainline Pipe and Fittings
 - f. PVC Sleeves
 - g. PVC Lateral Line Pipe and Fittings
 - h. Polyethylene Tubing (Emitter Risers)
 - i. Vinyl Distribution Tubing
 - j. Detectable Wire
 - k. Ball Valves
 - l. Remote Control Valves
 - m. Pressure Regulating Valves
 - n. Control Wiring and Waterproof Wire Splices
 - o. In-Line Screen Filters
 - p. Multi-Outlet Drip Emitters
 - q. Flush Cap Assemblies
 - r. Access Boxes for Ball Valves
 - s. Access Boxes for Remote Control Valves
 - t. Access Boxes for Pressure Regulator / Filter Assemblies
 - u. Access Boxes for Flush Cap Assemblies and Emitters
 - v. Master Control Valve

- B. Approvals: Irrigation materials and equipment shall not be delivered to the site or incorporated into the work until they have been approved in writing, by the City who shall have the authority to reject any substandard, or non-approved material, or any installation that does not meet the requirements of these specifications.
- C. As-Built Irrigation Drawings: The Contractor shall prepare and update on a daily basis, a complete set of record drawings showing the exact location of all pipelines, valves, and other sub-surface irrigation system components. Upon completion of the project the as-built information shall be transferred to a clean set of reproducible drawings provided to the City. The As-Built drawings shall be submitted and approved prior to Initial Acceptance of the irrigation system.
- D. Irrigation System Operating Instructions: After the system installation has been completed, the Contractor shall coordinate an on-site meeting with the City to instruct staff on the operation of the system. The Contractor shall also furnish two bound Operation and Maintenance Manuals, which shall include:
 - 1. Catalogue specification and spare parts sheets for each piece of irrigation equipment installed under this contract.
 - 2. Written operating and maintenance instructions for all major pieces of irrigation equipment.

9.6.9 STORAGE OF MATERIALS AND EQUIPMENT

- A. General: The contractor's equipment and materials shall only be stored in an on-site location approved by the City.
- B. PVC Pipe and Fittings: PVC Pipe and Fittings shall be protected from exposure to UV radiation while in storage. Storage of pipe shall be in accordance with the pipe manufacturer's recommendations.

9.6.10 PERMITS AND INSPECTIONS

The Contractor shall obtain and pay for all permits and inspection required by governing agencies.

9.6.11 STRUCTURES

The Contractor shall protect from damage during the performance of work specified in this Section, all structures and improvements as shown, scheduled, or required to remain on the site. The Contractor shall repair all damage resulting from negligence by the Contractor. Repair and replacement work shall be performed by the Contractor, as approved and at no additional cost to the City. The Contractor shall notify the City of any uncertainty or conflicts regarding the requirements of the Section and existing site conditions.

9.6.12 UTILITIES

- A. Blue-Staking: The Contractor shall have the project site Blue-Staked prior to the start of the Irrigation Work and shall keep the Blue-Staking current during the course of the project. All damage to existing utilities shall be repaired or replaced by the Contractor, as directed by the applicable utility company, at no cost to the City.

- B. Request to Mark Private Utilities: The Contractor shall request that the City identify and mark the location of all utilities on the site. All damage to existing utilities shall be repaired or replaced by the Contractor, as directed by and at no additional cost to the City.
- C. Unmarked Utilities: The Contractor shall notify the City of all other utility lines as may be encountered during the execution of the work. The Contractor shall not proceed without instruction from the City, except to correct an immediate hazard or emergency conditions.

9.7 IRRIGATION SYSTEM MATERIALS

9.7.1 PVC PIPE, SLEEVES, AND FITTINGS

- A. General Requirements: PVC Pipe and fittings shall be PVC plastic extruded from virgin parent materials and shall comply with ASTM standards D-1785-34 or D-2241-34 as applicable.
- B. Mainlines two inches (2") and smaller shall be Schedule 40 PVC and have solvent weld joints. Color shall be white.
- C. Mainline Fittings: Mainline fittings shall be Schedule 40 PVC fittings except in locations where Schedule 80 fittings are called-out on the project plans and details.
- D. Lateral Line Pipe and Headers: Lateral line pipe and headers shall be Schedule 40 PVC Pipe. Color shall be white.
- E. Lateral Line Fittings: Lateral line fittings shall be Schedule 40 PVC fittings.
- F. Pipe Sleeves: Pipe sleeves shall be Schedule 40 PVC pipe.
- G. Solvent Weld Primer: Solvent Weld Primer shall be as manufactured by IPS Weld-On, Type P-70 (Purple) or approved equal.
- H. Solvent Weld Cement: Solvent Weld Cement shall be as manufactured by IPS Weld-On, Type 711 (Gray) or approved equal.

9.7.2 POLYETHYLENE TUBING AND FITTINGS

- A. Polyethylene Supply Tubing: Tubing shall be constructed from linear, low density polyethylene resin and shall have a 0.350" O.D and a 0.250" I.D.. Tubing shall be as manufactured by Agricultural Products Inc. or approved equal.
- B. Polyethylene Distribution Tubing: Tubing shall be constructed from linear, low density polyethylene resin and have a 0.220" O.D. and a 0.160" I.D.. Tubing shall be as manufactured by Agricultural Products Inc. or approved equal.
- C. Fittings for Polyethylene Tubing: Fittings for tubing shall be a 0.350" O.D Compression x 0.5" SLIP Solvent Weld fitting as manufactured by Agricultural Products Inc. or approved equal.

9.7.3 VALVES

- A. Ball Valves: Ball Valves shall be of the full-port, two piece type constructed of bronze with chrome ball, PTFE seats, and NPT female connections. Ball valves shall be as manufactured by Watts, Model FBV or approved equal. Size shall be incoming pipeline size, or as noted on the drawings.
- B. All control valves must be solar compliant.
- C. In-Line Pressure Regulating Valves: Pressure regulating valves shall be of the permanently assembled type with heavy-duty plastic body and 1" female pipe thread ends. Valves shall have a pre-set outlet pressure of 30 psi. In-line pressure regulating valves shall be as manufactured by Senninger, Model PMR-MF-1", or approved equal.

9.7.4 BACKFLOW PREVENTER

- A. Backflow Preventer: The backflow preventer shall be of the reduced pressure principal type with bronze body. The device shall have an angle pattern configuration. The backflow preventer shall be as manufactured by Febco, Model 825-YA. Size shall be as noted on the drawings. Piping for backflow assembly shall be Galvanized steel with compatible fittings. Inlet and outlet connections shall be made with galvanized unions. All backflows shall be installed a minimum of 1 foot above finished grade. No backflows shall be installed below grade, backflows shall not be installed within underground vaults.
- B. Backflow Preventer Security Enclosure: The backflow preventer security enclosure shall be constructed of painted steel, shall have provisions for padlocking, and shall be suitable for installation on a concrete slab. The enclosure shall be as manufactured by LeMeur Manufacturing, Model LBF-SL-I, or approved equal. Color shall be tan.

9.7.5 CONTROL SYSTEM

- A. Controller/Power system: The nine-station controller shall be capable of operating four separate programs each with up to three start times. Controller shall be housed in a weatherproof, lockable stainless-steel cabinet. Controller shall be as manufactured by Hunter XC hybrid Stainless Steel with the Hunter provided solar package.
- B. Master Valve: The master valve shall be of the normally closed design (unless specified as normally open) with a brass body. The master valve shall be as manufactured by Rain Bird, Model 100-EFB-CP, or approved equal. Size as noted on the drawings.
- C. Controller Security Enclosure: Security enclosure shall be constructed of 3/16" steel plate with continuously hinged door and lock shield. Enclosure shall be equipped with mounting board, terminal strips, and convenience outlet. Enclosure shall be as manufactured by LeMeur, Model LE-A-CR, or approved equal. Color shall be "Desert Tan." The solar panel powering the controller shall be mounted to the security enclosure in such a way that it is inconspicuous to the general public but is still able to function as designed. This will serve to prevent vandalism of the equipment.

Sierra Vista Modified Maricopa County Roadway Design Manual

- D. Control Wire: Control wire shall be Type UF, solid core insulated wire. Wire size shall be #18 AWG as noted on the drawings. All wiring shall be installed in schedule 40 PVC conduit. Insulation color shall be as follows:

Common*	White
Control*	Red
Spare*	Green

*All wiring shall be installed in Schedule 40 PVC conduit.

- E. Waterproof Wire Splices: Waterproof wire splices shall be of the two-piece, sealant filled type, which permit the connection of three wires of 18 through 10 gauge. Wire splices shall be UL listed.
- F. Conduit for Low Voltage Control Wire: Conduit shall be Schedule 40 PVC conduit. Color shall be gray. Long radius ells shall be utilized where conduit terminates in pull boxes. Size shall be as required for the quantity of wires to be installed, but in no case should the size of the conduit be less than 1-1/2" size. All control wiring shall be continuous (no splices) from the control solenoid(s) to the controller. Splices are only allowed at manufacturer connection points for equipment.

9.7.6 EMITTERS

- A. Multi-Outlet Emitters: Emitters shall be of the multi-outlet, pressure compensating, assembled type with 1/2" FIPT threaded inlet and six outlets per emitter. The flow rate per outlet shall be approximately 1.0 gallon per minute. Emitters shall be as manufactured by Rain Bird, Model XBT 10-6 or approved equal. Emitter to polyethylene tubing adapter shall be 1/2" MT by .250 barbed sleeve Model 2088 manufactured by Landscape Products Inc. or approved equal.
- B. Vinyl Distribution Tubing: Vinyl distribution tubing shall be constructed of flexible polyvinyl materials with an .220" O.D. and a .160" I.D. as recommended by the emitter manufacturer. Distribution tubing shall be as manufactured by Agricultural Products Inc. or approved equal.

9.7.7 FILTERS

- A. In-Line Screen Filters: In-line filter shall be constructed with a heavy-duty plastic body, removable 150 mesh stainless steel screen, and integral flush valve. In-line filter shall be as manufactured by Agrifim, Model YSVS-100, or approved equal.
- B. "Y" Strainer for Backflow Preventer Riser: The "Y" filter shall be constructed of bronze, with 20 mesh stainless steel screen and NPT threaded connections. Strainer shall be 2"

9.7.8 VALVE ACCESS BOXES

- A. General Requirements: Valve access boxes shall be "tan" in color, constructed of heavy-duty reinforced plastic with locking lid, and include stainless steel lock down bolt.
- B. Access Boxes for Ball (Isolation) Valves and Pull Boxes for Control Wire/ Conduit: Boxes shall be as manufactured by Carson, Model 1419-12, or approved equal.

- C. Access Boxes for Master Valve and Remote-Control Valves: Boxes shall be as manufactured by Carson, Model 1200 Series - Jumbo, or approved equal.
- D. Access Boxes for Pressure Regulator/ Filter Assemblies: Boxes shall be as manufactured by Brooks, Model 1220-12 or approved equal.
- E. Access Boxes for Flush Cap Assemblies: Boxes shall be as manufactured by Carson Model 70, round box or approved equal.
- F. Access Boxes for Emitters: Boxes shall be as manufactured by Carson, Model 608, round box or approved equal.

9.7.9 MISCELLANEOUS IRRIGATION SYSTEM EQUIPMENT

Detectable Wire: Shall be Type UF, solid copper core insulated wire suitable for direct burial. Wire size shall be #14 AWG, orange in color. Wire to be installed along all PVC piping, taped to piping at 10' intervals and changes in direction. A 1' wire loop shall be provided in all valve boxes and 3" of excess wire shall be provided in changes of pipe direction. Wire splicing shall be kept to a minimum and will only be allowed within valve boxes. 

9.8 IRRIGATION SYSTEM EXECUTION

9.8.1 COORDINATION

Sequence of Work: The irrigation work shall be coordinated with the landscape planting work so that pipes, valves, emitter risers, and other fittings are installed in each planting area prior to the installation of plant material.

9.8.2 INSPECTIONS

Inspection of Layout Prior to Start of Trenching: The Contractor shall notify the City at least seventy-two (72) hours in advance of any excavation. Prior to the inspection, the Contractor shall mark the proposed layout/alignment of all mainlines and lateral lines as specified below.

9.8.3 COORDINATION OF NEW WATER METER INSTALLATION

Irrigation Water Meter: The Contractor shall contact the Water Company and shall submit an application for the installation of a new water meter at the location shown on the plan. Meter size shall be as noted on plan or be equal in size to the backflow preventer/mainline. The Contractor shall be responsible for the payment of all charges associated with the meter installation. The meter will be installed by the Water Company. The Contractor shall be responsible for the installation of all system components downstream of the new meter.

9.8.4 LAYOUT

- A. Layout of Work: The Contractor shall layout their work, staking out the location of all valves, mainlines, lateral lines / headers, and emitters. The layout shall be marked on the ground. Trenching work shall not begin until the layout has been approved by the City.
- B. Irrigation System Drawings: The location of some of the irrigation pipelines and equipment as shown on the drawings is diagrammatic and may be slightly distorted for drawing clarity. The layout of some irrigation pipelines shall be adjusted to avoid conflict with other existing or proposed improvements.
- C. Layout Adjustment: All changes to the layout of the irrigation system impacting the configuration of the system or the length of piping runs shall be presented to the City for approval prior to implementation of the layout change. All approved layout adjustments shall be clearly and accurately recorded on the as-built record drawings.

9.8.5 TRENCHING

Trenching work shall be straight and true and of the depth specified for the pipe to be installed. The Contractor shall be responsible for all bracing and shoring as may be required by applicable codes or as may be required for the work.

9.8.6 CONSTRUCTION OF PIPE AND TUBING JOINTS

- A. Cutting of PVC Pipe: PVC pipe shall be cut with a PVC pipe cutter or saw. All burrs shall be removed, and the exposed end of the pipe filed to create a small, beveled edge.
- B. Solvent Weld PVC Pipe Joints: Joints shall be made using the following procedures.
 - 1. Thoroughly clean the mating pipe and fitting with a clean, dry cloth.
 - 2. Apply a uniform coating of PVC primer to both the pipe and fitting as recommended by the primer manufacturer.
 - 3. Apply solvent weld cement to the pipe and fitting as recommended by the solvent weld cement manufacturer.
 - 4. Insert the pipe into the fitting and give the pipe or fitting a one-quarter turn to ensure that the pipe has been inserted to the full depth of the fitting socket and to ensure even distribution of the solvent weld cement.
 - 5. Hold the connection in position for fifteen seconds.
 - 6. Joints shall be allowed to set for a minimum of 24 hours before being pressurized.

9.8.7 INSTALLATION OF PIPE, SLEEVES, TUBING, AND DETECTABLE WIRE

- A. Sleeves: Sleeves shall be installed in all locations shown on the project drawings and in all other locations where irrigation pipes pass under paved surfaces. Sleeve sizes shall be as noted on the drawings. If sleeve size is not noted, it shall be a minimum of two nominal pipe sizes larger than the pipe enclosed, or two-inch diameter, whichever is greater.

1. Sleeves under existing pavement shall be installed by boring. Boring techniques shall be as approved by the City of Sierra Vista and shall not create voids under the asphaltic concrete pavement.
- B. Pipe: When installed in the trench, the PVC pipe shall be installed straight and true, with specified clearances between lines.
- C. Clearances: Irrigation lines shall have a minimum horizontal clearance of two inches (2") between parallel lines and two inches (2") between lines that cross.
- D. Bedding Material: All irrigation pipelines, sleeves and conduits shall have three inches (3") of sand bedding (concrete sand, 1/8" minus) material surrounding the installed pipe as shown in the City of Sierra Vista Standard Construction Details or plans.
- E. Depth of Cover: Irrigation Lines and detectable wire shall be installed so that the depth of cover is as follows:
 1. PVC Sleeves (for all pipes) Under Roadways..... 36 Inches
 2. PVC Mainlines - 2-1/2" and Larger.....36 Inches
 3. PVC Mainlines - 2" and Smaller 24 Inches
 4. PVC Lateral Lines / Headers 12 Inches
 5. PVC Conduit for Irrigation Control Wire 18 Inches
 6. Detectable Wire..... Depth of Pipe
 7. Polyethylene Tubing (between lateral and emitter) 4 Inches
 8. Emitter Distribution Tubing 2 Inches
- F. Installation of Polyethylene Tubing: Polyethylene tubing shall be installed as detailed. Except as approved by the Owner's Representative, the minimum radius on all bends in the tubing shall be eighteen inches (18"). Tubing shall be installed in a manner that prevents kinks that will reduce or impair water flow.
- G. Backfilling: After placement of pipe and bedding material, the irrigation trenches shall be backfilled with excavated native soil outside of the roadway prism. Any backfill within the roadway prism shall abide by City of Sierra Vista Standard Construction Details. Backfilling shall be done in 4" lifts and mechanically compacted prior to the placement of the subsequent lift. Compaction shall match the density of the adjacent undisturbed soil or shall be equal to 95% of the maximum density, whichever is more conservative.
- H. Repair of Settled Trenches: If, within two years from the date of completion, settlement occurs along irrigation trenches requiring repair or adjustment to the level of pipes, valves, valve boxes, or paving, the Contractor shall make such repairs at no cost to the Owner. Repair of settled areas and/or pavements is included in the scope of the Contractor's irrigation system guarantee.

9.8.8 INSTALLATION OF VALVES AND ACCESS BOXES

- A. Valves: Control Valves, ball valves, pressure regulating valves, and other system valves/related equipment shall be installed as detailed on the plans. The position of valves in access boxes shall allow for normal operation and servicing of the valve.

- B. Valve Access Boxes: Valve boxes shall not be modified unless approved by the City and all openings shall be filled with triple expanding, polyurethane insulating foam sealant to prevent soil infiltration. The reveal at the top of the box shall be as detailed. If the reveal is not detailed, it shall be one-half inch (1/2"). Where more than one valve is installed in a project location, the valves shall be grouped together, and the valve access boxes aligned.

9.8.9 INSTALLATION OF BACKFLOW PREVENTER AND SECURITY ENCLOSURE

- A. Backflow Preventer: The backflow preventer shall be installed as detailed and in accordance with code requirements. Testing of the device, if required by the Water Company, shall be performed by the Contractor with test certificates submitted to the Water Company as required.
- B. Security Enclosure: The backflow preventer security enclosure shall be installed as detailed and in accordance with the manufacturer's written instructions. The enclosure shall open and close without interference from the backflow preventer or other site improvements.

9.8.10 INSTALLATION OF CONTROL SYSTEM

- A. Security Enclosure: The controller security enclosure shall be installed as detailed with concrete foundation and ground rods. The enclosure location shall be as approved by the City.
- B. Controller: The controller shall be installed at a location approved by the Owner's Representative. The installation shall be in accordance with the manufacturer's instructions. The electrical and telephone services to the controller shall be as per applicable codes.
- C. Control Wire: Irrigation control wires, common wires, and spare wires shall be installed in Schedule 40 PVC conduit as detailed on the drawings.
 - 1. Control wire conduit shall include pull boxes at all changes in direction greater than 30 degrees and at intervals not to exceed two hundred feet (200').
 - 2. Irrigation Control Wire shall be sleeved separately from water lines under all paving.
- D. Spare Control Wires: The Contractor shall install two #14 AWG wires (with green insulation) along each run of control wires extending from the controller. The wires shall be terminated and secured, within the controller security enclosure, at the valve access boxes, and at the two most remote-control valve(s) in the system.

9.8.11 INSTALLATION OF EMITTERS

- A. Emitters shall be installed as detailed. Extend distribution tubing from the emitter to emission point as detailed. The position of the emission point relative to the center of the plant shall be as detailed.
- B. Number of Outlets per Plant: The quantity of emitter outlets installed per plant type shall be as scheduled on the drawings and as noted below:
 - 1. Trees: 6 outlets per plant

2. Shrubs and Groundcovers: 1 or 2 outlets per plant as noted on the Drawings.

9.8.12 PRESSURE TESTING OF MAINLINES AND HEADERS

- A. Flushing: After all piping and risers are installed and related work is complete, the Contractor shall flush the mainline and headers (lines between the remote-control valve and the in-line pressure regulating valve) with water to remove all soil and contaminants.
- B. Notification: The Contractor shall notify the City of his readiness to perform pressure testing a minimum of 72 hours prior to the scheduled start of the test. Except as may be approved by the City, all pressure testing shall be performed in his presence.
- C. Tools and Equipment: The Contractor shall provide all tools and equipment required for pressure testing and shall make all temporary connections / closures.
- D. Pressure Testing: The Contractor shall pressurize the mainline to a pressure of 100 psi and shall keep the mainlines and headers pressurized for a period of 6 hours. To be acceptable, the original test pressure shall be maintained for the duration of the test.
- E. Repairs - Retests: All defects which are found during the pressure testing shall be repaired using fittings and materials specified herein. Tests shall be repeated until satisfactory results are achieved.

9.8.13 OPERATIONAL TESTING OF SYSTEM

- A. Operational Testing of the Irrigation System: An operational test of the completed irrigation system shall be performed by the Contractor. The operational test shall be performed in the presence of the City. The test shall demonstrate that the controller and control valves are operating correctly and that all plants are receiving uniform amounts of water. Irrigation system components found to be operating incorrectly shall be repaired, replaced, or adjusted by the Contractor at no cost to the Owner.

9.8.14 CLEAN-UP

- A. Clean-Up: The Contractor shall perform clean-up operations daily during the course of the work and at the completion of the project. The Contractor shall remove from the site and legally dispose of all excess and waste materials.

9.8.15 CONTRACTOR MAINTENANCE AND ACCEPTANCE OF THE WORK

- A. Maintenance During Construction: The Contractor shall operate and maintain the irrigation system during project construction. Maintenance shall include, but not be limited to repair, replacement, and/or adjustment of components and reprogramming of controller. Maintenance during construction shall continue until Initial Acceptance of the Work
- B. Final Acceptance of the Work: Upon substantial completion of the irrigation work, the Contractor shall notify the City who will schedule an inspection of the project. During the inspection, items which are incomplete, or which must be repaired or replaced will be identified. Upon completion

Sierra Vista Modified Maricopa County Roadway Design Manual

or correction of the items noted, the City will issue written notice to the Contractor indicating Initial Acceptance of the Work. Final Acceptance of the irrigation system will be concurrent with the Final Acceptance of the landscape work.

- C. Final Warranty Acceptance: Upon completion and acceptance of the final warranty inspection, the City will issue written notice to the Contractor indicating Final Warranty acceptance. Upon completion and acceptance of the final warranty inspection. Upon issuance of this notice the City will assume responsibility for project maintenance. Final Warranty Acceptance of the irrigation system shall be concurrent with Final Warranty Acceptance of the landscape improvements.
- D. Responsibility for maintenance shall be established during the early design stages. No landscaping shall be installed in the City right of way without a prior finalized CC&R/Development agreement with the City. This agreement shall dictate maintenance responsibilities for the landscaping in the right of way and responsibilities for supporting infrastructure, i.e. backflow, meters, etc. Such arrangements will not only prevent jurisdictional problems from after construction but may also affect the design of facilities. Documents must state who is responsible for landscape maintenance. In addition, a Letter of Guarantee shall be obtained from the entity assuming future maintenance responsibilities.

9.8.16 GUARANTEE

- A. The Contractor shall guarantee the irrigation system installed be free from defects in materials and workmanship for a period of two (2) years commencing on the first day after Final Acceptance by the City.
- B. All irrigation system components that fail during the guarantee period, for reasons other than neglect, abuse, damage caused by others, or damage resulting from unusual phenomena beyond the Contractor's control, shall be repaired or replaced by the Contractor at no cost to the City. Repair and replacement work shall be subject to inspection and approval by the City. Replacements shall be made within 30 days of receipt of notice by the contractor.
- C. The Contractor shall submit a Letter of Guarantee, as provided by the City, and a monetary security in a form acceptable to the City, covering 110 percent of the landscaping costs, prior to Final Acceptance of the landscaping work. The security shall be returned after approval of the two-year guarantee inspection.

9.8.17 Sight Lines and Clear Distance Requirements

Clear distance requirements and sight lines shall conform to chapter 6 and 7 of this document.

9.8.18 ROADSIDE DEVELOPMENT

A. Clear Zone Restrictions

Trees and large shrubs whose trunk diameter at maturity will exceed 4 inches are not to be planted within the clear zone. The diameter measurement shall be taken at 12 inches above grade. Refer to Chapter 5 for information on clear zone width. The clear zone width is not to be considered a fixed single control dimension. Variations in cross section design and traffic speed may increase or decrease this distance. Shrubs and ground covers may be planted or retained within the clear zone for safety and aesthetic purposes as approved by The City. Existing trees may be retained under the following circumstances:

1. If they are on the high or cut side of the roadway beyond the clear zone distance or,
2. If they are on the low or fill side, if protected by a guardrail or beyond the clear zone

distance.

- B. Clear zone distances shall be maintained for newly planted trees and shrubs with an ultimate trunk diameter of more than 4 inches unless one of the following allows for a lesser distance:
 - 1. Ten feet (10') behind the point of vertical intersection (PVI) at the toe of cut slopes steeper than 3:1.
 - 2. Four feet (4') behind concrete barriers, walls, abutments, or other rigid obstructions.
 - 3. Four feet (4') behind flexible guardrail.

C. Offset and Clearance Distances for Trees

Offset and Clearance distances shall follow City of Sierra Vista Standard Construction Details and the most current standards put forth in the AASHTO roadside design guide.

9.8.19 LANDSCAPING IN MEDIANS

The trunks of vegetation that would exceed 4 inches in diameter at full maturity shall not be planted in the median except when located at least six feet (6') behind vertical curb.

Chapter 10 Pavement Design

10.1 GENERAL

10.1.1 OFFICE DATA

For information regarding future road buildout please reference the City of Sierra Vista General Plan found on the City of Sierra Vista Website. For streets managed and maintained by the City of Sierra Vista, criteria and street standards can be obtained from the City's Development Code or from the City's Engineering section.

Coordination with the Engineering Division, and ARIZONA 811 is required prior to conducting any field investigations or work in the Right-of-Way.

10.1.2 Traffic Historical Records

Historical records of traffic measurements are maintained by the SVMPO, and can be accessed online at:

<https://svmpo.public.ms2soft.com/tcds/tsearch.asp?loc=Svmpo&mod=>

10.1.3 Right-of-Way Permits / Jurisdictional Limits

City limit maps that delineate jurisdictional limits are available on the County website:

<https://gis-cochise.opendata.arcgis.com/apps/37d793d478664634b4de3ad8042f248a/explore>

Maps are provided for your convenience and should only be used as a guide. It will be the developer, or contractor's responsibility to determine the correct governing jurisdictions for permits. The permit requirements of the governing jurisdiction shall be followed when collecting field samples, field data, or performing any work in the Right-of-Way.

City right-of-way permits are obtained from the City's Engineering Division. Project fieldwork or any other work within the Right-of-Way shall be done in accordance with the permit requirements. Permission from the owner shall be obtained prior to work on any private property.

10.1.4 ARIZONA 811 (Formerly Arizona Blue Stake, Inc.)

Prior to excavating in any public right-of-way, utilities shall be located by following the procedures of Arizona 811, go to <http://arizona811.com/> or call 811.

10.1.5 FIELD DATA

A. Initial Site Visit for a New Pavement Section Design

During this initial inspection of the project, the design engineer should:

1. Determine the scope of the field sampling,
2. Begin to assess the potential distress mechanisms for existing pavements, and
3. Identify preliminary pavement design alternatives.

As part of this activity, subjective information of distress, road roughness, and moisture/drainage problems should be gathered. Unless traffic volume is a hazard, this data can be collected without any traffic control, through both “windshield” and road shoulder observations. In addition, an initial assessment of traffic control options, obstructions, and safety aspects shall be made during this visit.

The initial site visit has the following impacts on the scope of the subsequent primary field exploration:

4. Distress observations may help identify the collection interval, the number of surveyors, and any additional measurement equipment that might be required.
5. A general roughness assessment may dictate the need for a more rigorous measurement program to address ride quality related problems such as differential sags or swells.
6. Observation of moisture/drainage problems (e.g., standing water on pavement or ditches, settlement at transverse cracks, raveling in non-trafficked areas, and so on) may indicate the need for a more thorough investigation of subsurface drainage conditions.
7. Establishment of the sampling plan for the investigation.

B. Field Exploration

Field exploration is to be performed after establishment of an initial roadway profile grade.

The essential data collection activities include:

1. Distress and drainage surveys
2. Observation of land use and geologic features
3. Drilling and subsurface geotechnical investigations
4. Field sampling and testing

The minimum number of test holes and samples shall be in accordance with ADOT standards.

10.2 PAVEMENT DESIGN PROCEDURES

The City of Sierra Vista, has adopted the use of the Arizona Department of Transportation Engineering and Design Manual for use in development of design requirements for flexible pavement sections. In general, this process determines the thickness of subgrade treatment, Aggregate Base Course and Asphaltic Concrete a particular street will need to perform for an approximate 20 year cycle.

The following sections apply to flexible pavement designs. Concrete pavements shall be designed in accordance with the ADOT Pavement Design Manual² and ADOT construction standards, see section 10.2.6.

10.2.1 DESIGN VARIABLES

A. Analysis Period - 20 years

AASHTO definition:

Analysis Period: The period of time for which the analysis is to be conducted; analogous to the term “design life” used by designers in the past. This is the time period used in the AASHTO design equations. (AASHTO, p II-7)².

An analysis period of 20 years shall be used unless a specific request for a different period is made by the contracting agency. It is recognized that routine maintenance, such as sealing of cracks on a periodic basis, will be necessary during the life of the pavement, and that rehabilitation of the pavement surface may be needed before 20 years due to destructive climatic effects and deteriorating effects of normal use.

B. Design Traffic

Design traffic will be considered on the basis of cumulative 18-kip equivalent single axle loads (ESALs) during the analysis period. Traffic data will generally come from one or more of the following three sources:

1. Traffic studies provided for the project. These are generally presented in the Standard Data Release (SDR) from the City’s Metropolitan Planning Organization, or other design documents supplied by the developer’s engineer for the project.
2. Scope of work (for design consultants).
3. City of Sierra Vista Engineering Department

Table 10.2.1 summarizes the steps in calculating the design ESALs (W_{18}), and then calculating the desired structural number for a project. Note: Refer to the respective sections that follows this table for the meaning of symbols and more detailed steps.

TABLE 10.2.1 STEPS IN CALCULATING THE DESIGN ESALS (W_{18}) AND STRUCTURAL NUMBER (SN)

Step	Calculation
Initial Traffic Data	Obtain two-way ADT , traffic growth rate (g), and Truck Percentage (T)
Initial two-way daily traffic, measured in terms of 18-kip ESALs [$W_{0(2-18)}$]	$W_{0(2-18)} = \sum_{i=1}^k N_i TEF_i = N_1 TEF_1 + N_2 TEF_2 + \dots + N_k TEF_k$ Use if traffic classification data is available. Otherwise, use the simplified formula given on the next step.
Alternatively, use standard Traffic Equivalent Factor (TEF = 1.2) to calculate $W_{0(2-18)}$	$W_{0(2-18)} = (ADT \times \% \text{ Cars} \times 0.0008) + (ADT \times T \times 1.2)$
Calculate Overall Growth Factor (OGF)	$OGF = \frac{(1 + g)^n - 1}{g}$, where $n = 20$ years for most of the cases & $n = 4$ for temporary pavements
Calculate Two-way 18-kip ESALs for the analysis period (W_{2-18})	$W_{2-18} = 365 \times OGF \times W_{0(2-18)}$
Determine the traffic in the design lane (W_{18})	$W_{18} = W_{2-18} \times D_D \times D_L$, where D_D = directional distribution factor & D_L = lane distribution factor
Determine the desired Structural Number (SN)	$\log_{10}(W_{18}) = Z_R S_0 + 9.36 \log_{10}(SN + 1) - 0.2 + \frac{\log_{10}\left(\frac{\Delta PSI}{4.2 - 1.5}\right)}{0.40 + \frac{1094}{(SN + 1)^{5.19}}} + 2.32 \log_{10}(M_R) - 8.07$

1. Traffic Conversion from Average Daily Traffic (ADT) to Equivalent Single Axle Loads (ESALs)

The purpose of this procedure is to convert the traffic data, which is collected from traffic counts, into 18-kip Equivalent Single Axle Loads (ESALs). Pavement designers generally receive traffic information in the form of average daily traffic (ADT) or get printed lists of vehicle counts for a given period of time. The recommended method is to generally measure traffic for two 24-hour periods and then to report the numbers of vehicles per day. There are two methods of counting. One method counts total vehicles, and the other separates vehicle counts by classification and report the truck percentage. Procedures presented in this manual can accommodate either of the methods of counting traffic. Note: In addition to ADT and classification counts, if operational speed and axle configuration are available, they can be used as Mechanistic-empirical Pavement Design Guide: A Manual of Practice (MEPDG) design inputs.

2. Determination of Truck Load Factors

The preferred method is to use traffic data that includes all 13 of the vehicle classifications (Method 1): this data is to be used unless otherwise authorized by the City. If classification counts are not available, an alternate method for estimating traffic impact is presented in the paragraph titled Method 2: using the **Standard Traffic Factor for Heavy Trucks—Class ≥ 4**

Method 1: Using Traffic Factors for All Classifications

This method is the same as that presented in Appendix D of the 1993 AASHTO guide². A traffic equivalency factor is assigned to each of 13 vehicle classifications. The equivalency factors given on Table 10.2.2 are to be used.

TABLE 10.2.2 TRAFFIC EQUIVALENCY FACTORS (TEF)			
Class	Federal Highway Administration (FHWA) Description (Figure 2)	Traffic Equivalency Factor (TEF)	TEF for Method 2
1	Motorcycles	0	
2	Passenger Cars	0.0008	0.0008
3	Four Tire, Single Units	0.0122	
4	Buses	0.6806	
5	Two-Axle, Six-Tire, Single-Unit Trucks	0.1890	1.2
6	Three-Axle Single-Unit Trucks	0.1303	
7	Four or More Axle Single-Unit Trucks	0.1303	
8	Four or Fewer Axle Single-Trailer Trucks	0.8646	
9	Five-Axle Single-Trailer Trucks	2.3719	
10	Six or More Axle Single-Trailer Trucks	2.3719	
11	Five or Fewer Axle Multi-Trailer Trucks	2.3187	
12	Six-Axle Multi-Trailer Trucks	2.3187	
13	Seven or More Axle Multi-Trailer Trucks	2.3187	

Initial two-way daily traffic, measured in terms of 18-kip ESALs ($W_{0(2-18)}$) can then be determined by multiplying the daily number of vehicles in that classification times their corresponding equivalency factors and adding them all together. The following formula can be used:













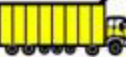

















$$W_{0(2-18)} = \sum_{i=1}^k N_i TEF_i = N_1 TEF_1 + N_2 TEF_2 + \dots + N_k TEF_k$$

Where,

- $W_{0(2-18)}$ = Initial 2-way daily 18-kip ESALs
- k = number of vehicle classifications considered
- N_i = Number of vehicles per day of a given classification
- TEF_i = Traffic Equivalency Factor for the given classification from Table 10.2.2

The initial two-way daily traffic is intended to represent the daily average traffic level in the first year the pavement is put into service. The traffic will usually increase from that point, at the selected growth rate, until it achieves the total number of ESALs at the end of the analysis period.

Figure 2. FHWA 13 Vehicle Category Classification.

Class 1 Motorcycles		Class 7 Four or more axle, single unit	
Class 2 Passenger cars		Class 8 Four or less axle, single trailer	
			
			
			
Class 3 Four tire, single unit		Class 9 5-Axle tractor semitrailer	
			
			
Class 4 Buses		Class 10 Six or more axle, single trailer	
			
			Class 11 Five or less axle, multi trailer
Class 5 Two axle, six tire, single unit		Class 12 Six axle, multi-trailer	
			
			Class 13 Seven or more axle, multi-trailer
Class 6 Three axle, single unit			
			
			

Method 2: Using Standard Traffic Factor for Heavy Trucks—Class ≥ 4

If vehicle classification data is not available in sufficient detail to use the 13 classifications

Sierra Vista Modified Maricopa County Roadway Design Manual

described above, a traffic equivalency factor of 1.2 shall be applied to the percentage of vehicles considered to be heavy trucks. This is based on the “approximation” method developed in the ADOT Pavement Design Manual¹. The remaining percentage of vehicles is considered to be cars. The designer shall then proceed as above except that there would only be two classifications, cars and heavy trucks. Cars are assigned a 0.0008 factor and heavy trucks are assigned a factor of 1.2 (See Table 10.2.2). The following formula shall be used to calculate the average two-way daily traffic, $W_{0(2-18)}$.

$$W_{0(2-18)} = (ADT \times \% \text{ Cars} \times 0.0008) + (ADT \times T \times 1.2)$$

Where,

- ADT = Average (two way) Daily Traffic
- $W_{0(2-18)}$ = Initial two-way daily 18-kip ESALs
- T = Percent All Trucks \geq Class 4 in Table 10.2.2
- % Cars = $1 - T$

a. Calculate ESALs over the Analysis Period

To complete the traffic conversion, the designer must calculate the amount of traffic over the entire analysis period, and apply a growth factor.

Annual growth rates should be supplied by the Engineering Division for each project. Growth rates are one of the most influential factors in the final thickness of the pavement, and they should be estimated as accurately as possible.

The following equation can be used to calculate an overall growth factor (OGF) based on annual growth rates.

$$OGF = \frac{(1 + g)^n - 1}{g}$$

Where,

- g = annual growth rate as a decimal number (i.e. use 0.05 in the equation for $g = 5\%$)
- n = number of years in the analysis period

This growth factor will have to be multiplied times the number of ESALs expected for the first year ($365 \times OGF$) to calculate W_{2-18} .

$$W_{2-18} = 365 \times OGF \times W_{0(2-18)}$$

Where,

- $W_{0(2-18)}$ = Initial two-way 18-kip ESALs
- OGF = Overall Growth Factor
- 365 = Number of days per year
- W_{2-18} = Two-way 18-kip ESALs for the analysis period

This number (W_{2-18}) will then need to be reduced for directional and lane distribution as described in the following section.

b. Traffic in the Design Lane, W₁₈

The following equation shall be used to determine the traffic (W_{18}) in the design lane:

$$W_{18} = W_{2-18} \times D_D \times D_L$$

Where:

W_{18} = the cumulative 18-kip ESAL units predicted for the design lane during the analysis period. The pavement design is based on this number.

D_D = a directional distribution factor, expressed as a ratio, that accounts for the distribution of ESAL units by direction, e.g., Eastbound, Northbound, etc.

D_L = a lane distribution factor, expressed as a ratio, that accounts for distribution of traffic when two or more lanes are available in one direction, and

W_{2-18} = the cumulative two-directional 18 kip ESAL units predicted for a specific section of highway during the analysis period (from the traffic data).

Although the directional distribution factor (D_D) is 50% for most roadways, there are instances where more weight may be moving in one direction than the other. An example of this is roadways leading to mine sites and/or aggregate suppliers. The side with heavier vehicles is used for the design or is separated out and designed for a greater number of ESALs. Experience has shown that D_D may vary from 0.5 to 0.7.

For the lane distribution factor (D_L), use Table 10.2.3 unless specific information to the contrary is known about the project:

TABLE 10.2.3 PERCENT OF 18-KIP ESALS IN DESIGN LANE (D_L)	
Number of Lanes in Each Direction	Percent of 18-kip ESALS in Design Lane (D_L)
1	100
2	90
3	70
4	60

C. Reliability

Reliability concepts are used in pavement design to consider the likelihood that the design will achieve its performance criteria. It is necessary to apply these statistical concepts because of the variability of input parameters such as traffic prediction, performance prediction, materials, and construction practices. Reliability concepts are incorporated into pavement design using two statistical parameters. Those parameters are Level of Reliability and Overall Standard Deviation (S_0).

The following levels of reliability (Table 10.2.4) and overall standard deviation shall be used for pavement designs in The City of Sierra Vista. Corresponding values of the standard normal random variable (Z_R) are also presented for assistance in design calculations as needed.

TABLE 10.2.4 LEVEL OF RELIABILITY			
Functional Classification *	Reliability	Z_R Value	Std. Dev. (S_0)
Highways and Parkways	95 %	-1.645	0.45
Arterials & Industrial	95 %	-1.645	0.45
Collectors	90 %	-1.282	0.45
Residential (Local)	80 %	-0.841	0.45
* See Chapter 2 for Functional Classification Definitions.			

D. Performance Criteria (Serviceability)

The Present Serviceability Index (PSI) is the performance criterion for flexible pavement design. A pavement’s PSI can range from 0 (impossible road) to 5 (perfect road). The values in Table 10.2.5 shall be used for Initial Serviceability (P_0), Terminal Serviceability (P_t), and Change in Serviceability (Δ_{PSI}).

TABLE 10.2.5 PRESENT SERVICEABILITY INDEX (PSI)			
Functional Classification *	P_0	P_t	Δ_{PSI}
Highways and Parkways	4.6	2.7	1.9
Arterials & Industrial	4.5	2.5	2.0
Collectors	4.4	2.3	2.1
Residential (Local)	4.2	2.0	2.2
* See Chapter 2 to determine Functional Classification.			

10.2.2 MATERIAL PROPERTIES FOR STRUCTURAL DESIGN

A. Effective Roadbed Soil Resilient Modulus

Required thickness and strength for the pavement is heavily influenced by the quality of the roadbed soil (subgrade). The measure of “quality” of roadbed soil is defined by AASHTO as the soil resilient modulus (M_R). Because of the difficulty and expense to measure M_R directly, the quality of roadbed soil in the City can be determined with measured and correlated R- values converted to resilient modulus. The City of Sierra Vista method for developing roadbed soil resilient modulus is presented below in Section 10.2.2.1.1.

The 1993 AASHTO guide provides a method to evaluate the resilient modulus in various moisture states representing different seasons of the year. Because of the relatively low effect of seasons on the condition of subgrade soils in the deserts of Arizona, that procedure will not be required for City of Sierra Vista projects. A single design value of resilient modulus can be used for the pavement design.

An option for using sieve analysis and plasticity index (PI) to evaluate the roadbed soil is available for local and minor collector roadways. This method uses charts where the Percent Passing the No. 200 Sieve (P_{200}) and PI are plotted and used to select the needed base course thickness. This chart

method is presented in Section 10.2.5. The charts are NOT appropriate for roadways other than local and minor collectors.

B. Roadbed Soil Resilient Modulus for Flexible Pavement Design

Roadbed soil resilient modulus is a required input for flexible pavement designs. It can be estimated from R-value test results of subgrade soils. On large projects, many R-values would be necessary to acquire enough tests to adequately represent the subgrade soils on the project. To reduce cost and time in acquiring so many R-values, the ADOT has developed a method to combine measured R-values with correlated R-values (using PI and P_{200} results). The procedures presented here are modifications of those developed by the ADOT as presented in their Pavement Design Manual¹.

1. Initial Testing of Sieve Analysis and Plasticity Index

The first step is to sample and test the subgrade at the specified frequency. After the design engineer has completed a field reconnaissance, samples are to be taken such that all of the soil types anticipated in the pavement subgrade are represented. Sufficient soil shall be obtained in each sample to test sieve analysis (sieve), plasticity index (PI), expansion, R-value, and any other test the pavement designer deems appropriate for the needs of that specific project. The samples are to be returned to the laboratory and each sample shall be tested for sieve and PI. The representative remnants of each sample shall be held in the laboratory until they are assigned for other testing, including R-value, expansion, pH, and resistivity testing.

2. Initial Evaluation of Sieve Analysis and Plasticity Index

The sieve and PI test results are then used to calculate correlated R-values (R_{cor}) using the following equations:

$$SPF = 2.05 - 0.0033 P_{200} - 0.017 PI$$

$$R_{cor} = 0.018e^{SPF/0.235} + 6.0$$

$$\text{If } R_{cor} > 70, \text{ set } R_{cor} = 70$$

Where,

PI = Plasticity Index

P_{200} = Percentage Passing No. 200 Sieve from the sieve analysis

SPF = Sieve and PI factor

Note: This equation for correlated R – value is a variation of that presented in the ADOT Pavement Design Manual¹.

A table of test results and corresponding R-value estimates is then prepared. This table includes the average and standard deviation of the correlated R-values for the project. If the standard deviation of the R-values is high (i.e. greater than 10), the design engineer shall review the project and site conditions to see if the project should be divided into multiple segments to accommodate different pavement sections. If more than one segment is warranted, then a correlated R-value table shall be prepared for each segment. A separate table is not necessary for pavement sections designed using the same subgrade resilient modulus.

Selection of which subgrade samples will be tested for R-value is made after reviewing the correlated R-value table. The samples shall be selected such that R-values will be measured from the full range of correlated R-values on the project. The number of R-values tested should be about ½ the number of subgrade sieve and PI results. This means that only half of the held samples in the laboratory would be used. However, a minimum of 3 measured R-values is required for each project or each segment of a project.

EXCEPTION: If the average correlated R-value is 50 or greater and the standard deviation is less than 10, it is not necessary to run any R-values. The mean R-value can be calculated from the correlated values.

The pavement designer may elect to select samples for R-value testing based on visual descriptions of the soils prior to sieve and PI testing in order to save time. This will be considered acceptable if the engineer’s judgment and visual classification skills are sufficient to accomplish the intent of the selection process. If the criteria of the selection process are not met, additional samples shall be tested to establish a reasonably accurate understanding of the subgrade modulus.

3. **R – Value Analysis**

After the selected R-value tests are completed, the results shall be added to the correlated R-value table for analysis. Average and standard deviation values for measured R-values shall be made separate from those for the correlated R-values.

The pavement designer reviews the average and standard deviation values of both measured and correlated R-values to make the final decision about recommending different segments. Again, separate summary tables are to be prepared for each segment of work (different subgrade) if different subgrade resilient modulus (M_R) values are used.

4. **Adjustment for Highly Variable Soil Conditions**

If the standard deviation of either correlated or measured R-value is greater than 10, an adjusted average value shall be calculated to reduce the value by the amount in excess of 10. No adjustment should be made if the standard deviation is less than 10. For Example:

$$\begin{aligned} \text{Average } R - \text{value} &= 27 \\ \text{Standard Deviation} &= 13 \\ \text{Adjusted Average } R - \text{value} &= 27 - (13 - 10) = 24 \end{aligned}$$

5. **Calculate Mean R-Value**

A mean R-value is then calculated using the following equation:

$$R_{mean} = \frac{2N_t R_t SD_c^2 + N_c R_c SD_t^2}{2N_t SD_c^2 + N_c SD_t^2}$$

Where,

N_t = number of measured *R – values*

N_c = number of correlated *R – values*

R_t = adjusted average of the measured *R – values*

R_c = adjusted average of the correlated $R - values$
 SD_t = standard deviation of the measured $R - values$
 SD_c = standard deviation of the correlated $R - values$

The mean R-value is then used to calculate the subgrade soil resilient modulus (M_R) using the equation presented below. If the calculated subgrade soil resilient modulus is greater than 26,000 psi, the value used for design purposes shall be 26,000 psi 

$$M_R = \frac{(1815 + 225 R_{mean} + 2.40 R_{mean}^2)}{0.6 SVF^{0.6}}$$

Where,

M_R = Subgrade Soil Resilient Modulus in pounds per square inch (psi)

SVF = Seasonal Variation Factor

R_{mean} = Mean $R - value$ as calculated above

This subgrade soil resilient modulus (M_R) can then be used in the flexible pavement design portion of this guide to calculate the structural number (SN) that the pavement should provide.

C. Local Roads and Roadway Widening

There are two conditions for which a pavement design can be performed without using the procedures presented above for determining subgrade soil resilient modulus. For these two conditions, the designer will use *Sieve* and PI test results on simple design charts, or use correlated R-values without any tested R-values.

Condition 1:

The first condition is for local residential and minor collector streets where lower reliabilities are allowed. On these roadways, it may be more useful for the designer to have many *Sieve* and *PI* results to identify changes in subgrade verses more accurate $R - value$ tests in fewer locations. See Section 10.2.6 (Alternative Design Method for Local and Minor Collector Roads) for designing local and minor collector streets based on *PI* and P_{200} .

Condition 2:

The second condition uses only correlated R-values for short sections (1,000 feet or less) of roadway widening or other projects where minor additions are being made to an existing pavement.

For these projects, the designer shall perform a pavement condition survey on the existing pavement and evaluate the performance of the structural section under the loading up to that point in time. Consideration should be given to match the existing section unless it has not performed sufficiently or if traffic has increased or is expected to increase.

1. Layer Coefficients (a_i)

The final pavement will typically be comprised of more than one layer of different materials (See Figure 3). A simple flexible pavement structure is comprised of asphalt concrete (AC) and aggregate base (AB) course (2 layers). The number of layers will be three if asphalt rubber (AR) is used as the surface course (Figure 3). Each layer is assigned a structural layer coefficient (a_i)

Sierra Vista Modified Maricopa County Roadway Design Manual

by the designer. This coefficient is used to convert actual layer thickness into a structural number (SN). Higher coefficients represent more contribution (per inch) to the structural capacity and longevity of the pavement. These coefficients will be used in the structural design formula presented in the “Selection of Layer Thicknesses” section below. The layer coefficients in Table 10.2.6 shall be used.

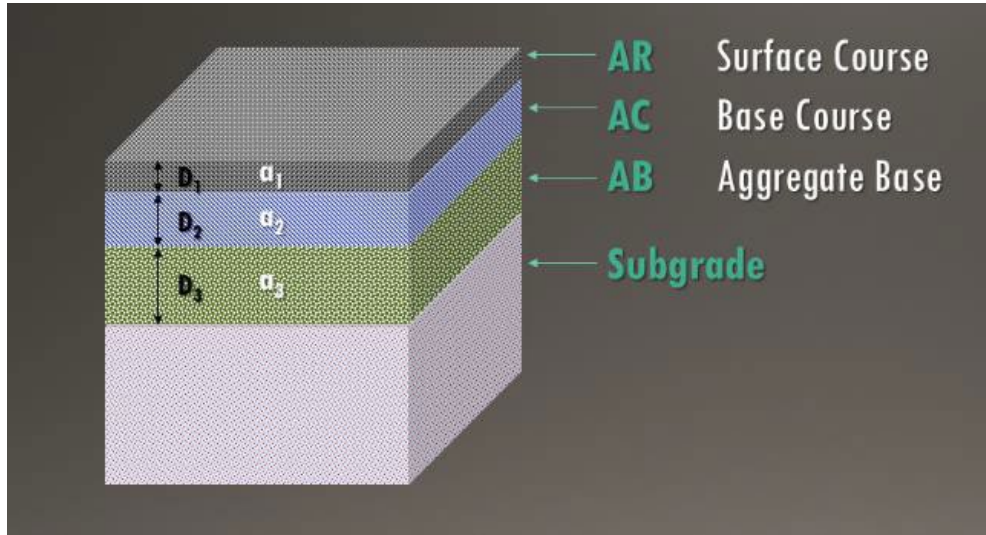

Figure 3. Typical Pavement Structure.

TABLE 10.2.6 STRUCTURAL LAYER COEFFICIENT (a_i)		
Material Description	Structural Layer Coefficient, a_i	Thickness Constraint
Asphalt Rubber Asphalt Concrete (ARAC)	0.42 ^a	Minimum 1.5 in. ^b Maximum 2.0 in. ^c
Asphalt Concrete (AC)	0.42	Based on Layered Analysis
Cement Treated Base (CTB)	0.28	Minimum 4.0 in.
Aggregate Base (AB)	0.12	Minimum 4.0 in.
MAG Select	0.11	Minimum 4.0 in.
Stabilized Subgrade	0.16 to 0.23 ^d	Minimum 6.0 in.

^a In order to consider the superior performance in resistance to cracking and other aging characteristics, a structural layer coefficient of 0.61 may be used for ARAC (MAG Sections 325 and 717) only for 1.5-inch thickness, when used as a surface course on top of 3 inches or greater of conventional asphalt pavement (MAG Sections 321 and 710).

^b Minimum thickness can be reduced to 1.0 inch for hot-in-place recycling (HIPR) pavement construction.

^c In rare cases, when using 2 inches of ARAC, structural layer coefficient of 0.61 can be used for the top 1.5 inches. The bottom 0.5 inches should use 0.42 coefficient provided that the base course meets the 3-inch minimum requirement.

^d The coefficient for stabilized subgrade is to be determined using a non-soaked 7-day compressive strength, using ASTM D1633 Method A, and the following formula:

$$a_i = 0.15 + 0.0001 (\text{CSCLS})$$

Where: CSCLS = Compressive strength of cement or lime stabilized subgrade in psi.

10.2.3 PAVEMENT STRUCTURAL –DRAINAGE

The capability of a roadway to shed water is another factor in roadway and pavement design. The pavement designer must select a drainage coefficient (m_i) to represent the effects of the drainage quality on the needed pavement structure. This coefficient is related to the quality of the roadway’s drainage (i.e. how long before water is removed) and the anticipated percent of time the pavement structure is exposed to moisture levels approaching saturation.

ADOT has developed drainage coefficients throughout the state based on AASHTO guidelines and their experience. The ADOT method relates drainage coefficients to an Arizona map that establishes zones of seasonal variations. Drainage coefficients using the ADOT method for City of Sierra Vista are presented in Table 10.2.7 and shall be used for City designs. Table 10.2.7 also presents the AASHTO criteria for establishing drainage quality based on the time needed for water to be removed from the pavement.

TABLE 10.2.7 DRAINAGE COEFFICIENT (m_i)		
Drainage Quality	Drainage Coefficient ADOT¹	Water Removed Within AASHTO², page II-22
Excellent	1.15	2 hours
Good	1.07	1 day
Fair	1.00	1 week
Poor	0.93	1 month
Very Poor	0.86	Water will not drain

Highways elevated two feet or more above the adjacent ground surface, having a minimum crowned cross slope of 2.0%, and a graded shoulder carrying water 10 feet or more away from the outside edge of the outside lane shall be considered to have “good” drainage. Roadways designed with concrete curbs and drop inlet drainage meeting City standards shall be considered to have “fair” drainage, and a drainage coefficient of 1.00 is recommended.

10.2.4 FLEXIBLE PAVEMENT DESIGN

After determining the selected parameters for design variables, performance criteria, material properties, and drainage, proceed through the AASHTO design equations to determine the appropriate thickness of each of the pavement layers. The equations are used in a series of steps. First determine the *required structural number*, then *select layer thicknesses*, and finally apply a *layered design analysis*. Additional steps of evaluating staged construction alternatives and roadbed swelling shall be added to the design as needed. Each of these steps will be considered in the following sections of this guide.

In no case shall the minimum pavement cross-section be less than the following:

- Arterials and Collectors Designated on Traffic Circulation Plan - 3 inches of asphaltic concrete over 10 inches of aggregate base.
 - Special Considerations to the pavement structural section shall be given in areas where heavy truck traffic is anticipated. The City Engineer may require a formal pavement design report to be submitted for approval for such areas. The Engineer shall design the pavement structural section as defined in this manual, or as stated within the pavement design report, whichever is most restrictive.
- Residential Locals and Alleys - 2 inches of asphaltic concrete over 6 inches of aggregate base.

A. Determining Required Structural Number

Flexible pavement design is based on determining a structural number (SN) that, given the subgrade conditions of the pavement, can withstand the projected number of ESALs. As mentioned earlier, this method is based on the 1993 AASHTO Design Guide, the structural number equation and design nomographs can be found in the 1993 AASHTO guide. And, in the past they had been acquired through commercially available design software packages such as AASHTO's DARWin program. Note that the DARWin program is no longer available and it was replaced with the new AASHTO Pavement ME Design software. The MCDOT MEPDG (posted online) provides the ME (Mechanistic Empirical) design procedure.

The output of the 1993 AASHTO Design Guide calculations is the Design Structural Number (SN). The equation is as follows:

$$\log_{10}(W_{18}) = Z_R S_0 + 9.36 \log_{10}(SN + 1) - 0.2 + \frac{\log_{10} \left(\frac{\Delta_{PSI}}{4.2 - 1.5} \right)}{0.40 + \frac{1094}{(SN + 1)^{5.19}}} + 2.32 \log_{10}(M_R) - 8.07$$

Where,

- W_{18} = Total accumulated traffic in ESALs for the design lane
- S_0 = Overall standard deviation
- M_R = Effective roadbed soil resilient modulus
- Δ_{PSI} = Design serviceability loss
- Z_R = Standard normal random variable

Structural number (SN) obtained from the above equation will be compared with the minimum structural number shown in Table 10.2.8 for the appropriate roadway type. The larger SN shall be used for pavement design.

TABLE 10.2.8 MINIMUM STRUCTURAL NUMBER BASED ON ROADWAY TYPE		
<i>Roadway Classification</i>		<i>SN (Min.)</i>
<i>Rural</i>	<i>Urban</i>	
Principal Arterial	Principal Arterial	2.88
Minor Arterial	Minor Arterial	2.88
Major Collector	--	2.46
--	Major Collector (Industrial/Commercial)	2.88
--	Major Collector (Residential)	2.13
Minor Collector	--	2.46
--	Minor Collector (Industrial/Commercial)	2.88
--	Minor Collector (Residential)	2.13
Local Road (Residential)	Local Road (Residential)	1.77
Local Road (Industrial/Commercial Subdivisions)	Local Road (Industrial/Commercial Subdivisions)	2.88

B. Selection of Layer Thicknesses

After the design structural number (SN) has been determined, develop layer thicknesses which, when combined, will provide the load carrying capacity to meet the design structural number. The following equation is used to accomplish this.

Where,

$$SN = a_1D_1 + a_2D_2m_2 + a_3D_3m_3 + \dots$$

a_1, a_2, a_3 = layer coefficients representative of surface, base, and subbase courses, respectively.

D_1, D_2, D_3 = actual thicknesses of surface, base, and subbase courses, respectively.

m_2, m_3 = drainage coefficients for unbound layers (base and subbase, respectively).

The designer can conceive various alternative combinations of layers and thicknesses that will achieve the required design structural number (SN). Several different combinations are to be developed. The final design recommendation will be made after these alternative combinations are evaluated based on:

- A. Layered design analysis.
- B. Evaluation of the expansion potential of the subgrade.
- C. Construction cost analysis for the pavement.

C. Layered Design Analysis

The pavement structure is a layered system and each underlying layer affects the layers above it. The design equation presented above can be used to evaluate the adequacy of each layer to support the layers above it. The minimum SN for the pavement structure above a particular layer may be computed using the AASHTO formula and the resilient modulus (M_R) for that layer. The 1993 AASHTO guide (Page II-36) should be referred to for a more complete explanation of the layered analysis approach.

A layered design analysis does not change the design structural number, but affects limits on some of the layer thicknesses. The most common impact on pavement designs is that it requires thicker layers of asphalt concrete (AC) on roadways with high traffic volumes. A layered design analysis

is required for City of Sierra Vista pavement designs.

1. Construction Constraints for Layer Thickness

The design thickness of asphalt concrete (AC) shall be rounded upward to the nearest ½-inch increment. The design thickness of granular aggregate base (AB) shall be rounded upward to the nearest 1-inch using a minimum layer thickness of 4-inches. The designed thickness of stabilized native or base shall be rounded upward to the nearest 1-inch with a minimum layer thickness of 6-inches. Refer to Table 10.2.6 for thickness constraints adopted by The City. .

For constructability, the design asphalt concrete layer thicknesses should be subdivided into thicknesses complying with MAG Table 710-1 (Recommended Lift Thickness For Asphalt Concrete Mixes).

D. Expansive and Collapsible Soils

Expansive soils in the roadway subgrade are detrimental to pavement performance in several ways. The resilient modulus of expansive soils is generally very low, expansion of the subgrade can reduce the ride quality and decrease the pavement’s serviceability ratings, and differential movements can crack the pavement and propagate local failures causing increased maintenance costs. The pavement design process will incorporate the following measures in consideration of these detrimental effects.

Subgrade soils having a plasticity index (*PI*) above 15 with more than 20% passing the No. 200 sieve (*P200*) shall be considered potentially expansive. The engineer shall take additional samples or test existing samples as necessary to ensure that a minimum of 3 samples of any potentially expansive soil are tested. The treatment described in Table 10.2.9 will then be required based on the average of the three samples with the highest expansion potential. If it is not possible to obtain 3 samples representing a given expansive soil, the treatment given in Table 10.2.9 will be based on the test result of the sample with the highest expansion potential.

Samples for expansion tests shall be re-molded in accordance with ARIZ 249 (ADOT Materials Testing Manual) to 95% of maximum dry density and at 2% below optimum moisture as determined by ASTM D698 and tested for one-dimensional expansion in accordance with the applicable portions of ASTM D4546 applying a surcharge of 144 psf. At the discretion of the pavement designer, the surcharge load can be adjusted to match the overburden produced by a reasonable estimate of the proposed design pavement section. Testing and calculation of swell pressures will not be required.

An alternative to the prescribed treatments is to remove the subgrade soils to a depth of 24 inches below the bottom of base course and replace with a non-expansive and otherwise suitable soil.

Some sandy-silty soils exhibit high level of collapsibility due to wetting. In some cases, in-place densities are low and at the same time show low dry strength and the soils are identified as loose or very loose. In both of the above cases, over-excavation and re-compaction should be considered.

**TABLE 10.2.9 – RECOMMENDED TREATMENT FOR SWELLING
SUBGRADE SOILS**

Expansion Potential	Recommended Treatment
----------------------------	------------------------------

Sierra Vista Modified Maricopa County Roadway Design Manual

< 2%	None
2% to 5%	Stabilize ^a in place to a depth of 6 inches
> 5%	Stabilize ^b with lime to a depth of 12 inches
<p>^a The soil can be stabilized with either lime, cement or lime/cement combination by specifying the requirements of MAG Section 309 Lime Slurry Stabilization or MAG Section 311 Soil Cement Base Course. For either method, a minimum compressive strength of 160 psi shall be achieved when tested as required by the specifications.</p> <p>^b The soil should be stabilized with lime in at least two layers following the requirements of MAG Section 311. The bottom layer can be stabilized in place.</p>	

Some silty sand or sandy silt soils have a high P_{200} but are non-plastic. Such soils are usually sensitive to moisture content and are difficult to compact into a firm grade. In such case, soil cement base may be considered.

10.2.5 ALTERNATIVE DESIGN METHOD FOR LOCAL AND MINOR COLLECTOR ROADS

For local and minor collector roads, an alternative simple design procedure is available to pavement designers. This method utilizes *Sieve* and *PI* data to evaluate the subgrade and does not require traffic analysis except as necessary to determine the roadway classification.

A. Sampling

Test holes for the soils investigation segment of the pavement design shall be within the pavement alignment, and shall be spaced at one (1) per eight hundred (800) lineal feet with at least one per proposed street. Each test hole shall be advanced to 24 inches below the elevation of proposed subgrade if there is no significant cut or fill required. In areas of cut or fill, the Engineer shall use his professional judgment to determine the depth of each test hole. The intent of the test hole depth is to achieve a minimum of 2 feet of the final roadway’s subgrade materials sampled and tested. Additional test holes shall be taken at apparent changes in soil type.

B. Testing and Design

As a minimum, at least one soil sample from each test hole shall be tested for sieve analysis (AASHTO T27) and *PI* (AASHTO T89 & T90). Resulting test values of *PI* and P_{200} are then used in design Charts 100A, 100B, 200A, and 200B to determine the base requirements of the asphalt pavement structural section. Table 10.2.10 provides a guide to each chart.

If a soil sample exhibits *PI* greater than 15 with P_{200} greater than 20, then an expansive potential test shall be performed in accordance with Section 10.2.4.4. If the expansion potential is equal to or greater than 2 percent, use Design Charts 100B and 200B to determine the base requirements of the asphalt pavement structural section.

TABLE 10.2.10 DESIGN CHARTS SUMMARY FOR LOCAL & MINOR COLLECTOR ROADS			
Road Classification	Subgrade Type	Minimum AC Thickness	Minimum AB or AB/LSS Thickness

Sierra Vista Modified Maricopa County Roadway Design Manual

Minor Collector	Non-Expansive	3.0 in.	See Chart 100A
	Expansive	3.0 in.	See Chart 100B
Local	Non-Expansive	2.0 in.	See Chart 200A
	Expansive	2.0 in.	See Chart 200B

The designer has two options for determining the design values of PI and P_{200} :

Option 1:

The first option is to plot all of the test sample values of PI and P_{200} and then select the sample resulting in the highest thickness of base course. This option shall always be used if fewer than 5 samples are used in the design.

Option 2:

The second option is to use a weighted average approach. This approach can be accomplished with the following steps:

- Summarize all of P_{200} and PI data on a chart along with calculated estimates for R-value and Resilient Modulus (M_R) using the formulas presented in Section 10.2.2.1.1. Standard deviations for each parameter shall be presented on the summary chart as shown on the example in Table 10.2.11.
- When the chart is completed, the engineer will be able to identify if more than one pavement section would be beneficial for the project. If more than one section will be designed, each section is to have a separate chart summarizing the test results applicable to that design.
- Use the summary chart to determine the weighted average values for PI and P_{200} . The weighting will tend to place more emphasis on the poorer soils rather than the better soils, and will not allow excessive variation from the average to the poorest soils encountered. Eliminating the test samples with the highest resilient modulus values one at a time until the standard deviation of the remaining resilient modulus values is less than 8,000 psi produces the weighted average. The P_{200} and PI results from these “remaining” samples are then used to calculate the weighted average.
- Calculate the weighted average values for P_{200} and PI by adding one standard deviation to their remaining averages. The adjustments made following the above three steps are shown in Table 10.2.12.
- Plot these weighted average values on Design Chart Series 100 or 200 to determine the required base course thickness to go with the predetermined asphalt concrete thickness.
- Design Chart Series 100 & 200 that consist of four charts are included after the following two tables.

TABLE 10.2.11 TEST DATA SUMMARY				
Test Hole No.	PI	P_{200}	Correlated R-value (psi)	Resilient Modulus (psi)

Sierra Vista Modified Maricopa County Roadway Design Manual

1	8	39	42.7	26,301
2	11	50	32.6	19,491
3	19	41	27.0	16,053
4	17	30	34.0	20,375
5	16	31	34.8	20,941
6	33	75	9.7	7,061
7	34	77	9.1	6,778
8	30	72	11.4	7,833
9	9	21	52.6	33,818
10	15	16	44.6	27,681
11	15	12	47.1	29,559
12	12	12	53.0	34,109
13	6	6	72.8	51,503
14	12	18	48.8	30,815
15	21	46	23.3	13,923
16	21	49	22.3	13,396
17	20	13	38.2	23,183
18	12	12	53.0	34,109
19	15	13	46.5	29,075
Average	17	33	37	23,474
St Dev	8	23	17	11,400 ^a
Avg. + St Dev	25	56	^a Note: Since 11,400 is greater than 8,000, eliminate data, beginning with the highest Resilient Modulus, one test hole at a time, until the standard deviation of the resilient modulus values is less than 8,000.	

TABLE 10.2.12 TEST DATA SUMMARY–WITH WEIGHTED AVERAGE				
Test Hole No.	PI	P₂₀₀	Correlated R-value (psi)	Resilient Modulus (psi)
1	8	39	42.7	26,301
2	11	50	32.6	19,491
3	19	41	27.0	16,053
4	17	30	34.0	20,375
5	16	31	34.8	20,941
6	33	75	9.7	7,061
7	34	77	9.1	6,778
8	30	72	11.4	7,833
9				
10	15	16	44.6	27,681
11				
12				
13				
14	12	18	48.8	30,815
15	21	46	23.3	13,923
16	21	49	22.3	13,396
17	20	13	38.2	23,183
18				
19				
Average	20	43	29	17,987
St Dev	8	22	13	7,962 ^a
Avg. + St Dev (Weighted Avg.)	28	65	^a Note: Six test holes were eliminated from the data to bring the standard deviation of resilient modulus to less than 8,000.	

DESIGN CHART 100A
 Depth of Aggregate Base for Minor Collector
 Non-Expansive Subgrade

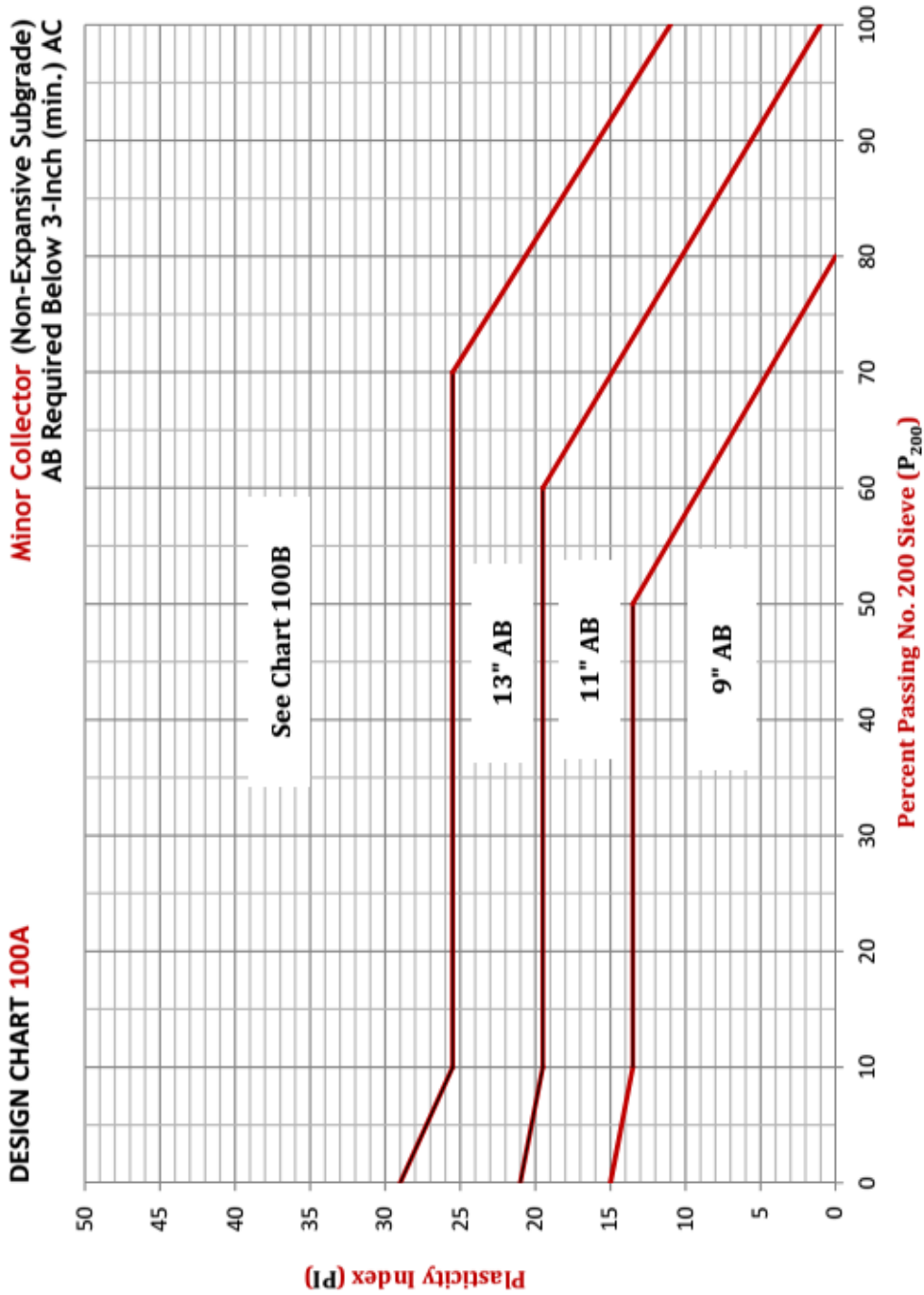

- NOTES:**
- (1) AB = Aggregate Base course (MAG 702.2).
 - (2) Subgrade for all curb, gutter, and attached sidewalk shall be stabilized to match stabilization depth of pavement section.
 - (3) This detail is also applicable for industrial/commercial roads with 4" (minimum) of asphalt concrete.

DESIGN CHART 100B
 Depth of Aggregate Base for Minor Collector
 Expansive Subgrade

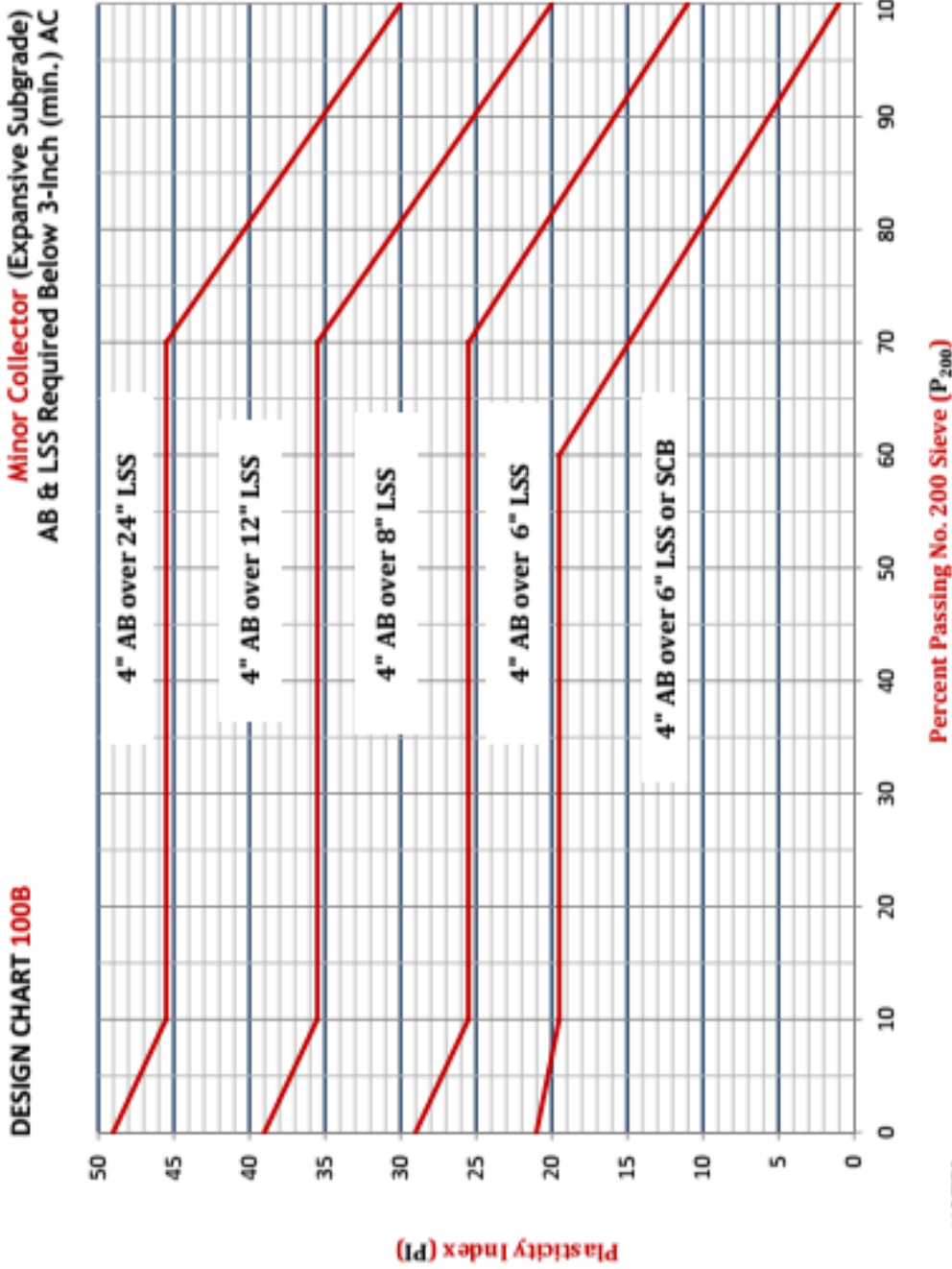

- NOTES:**
- (1) AB = Aggregate Base course (MAG 702.2).
 - (2) LSS = Lime Slurry Stabilized Subgrade (MAG 309).
 - (3) SCB = Soil Cement Base (MAG301).
 - (4) Subgrade for all curb, gutter, and attached sidewalk shall be stabilized to match stabilization depth of pavement section.
 - (5) This detail is also applicable for industrial/commercial roads with 4" (minimum) of asphalt concrete.

DESIGN CHART 200A
 Depth of Aggregate Base for Local Roads
 Non-Expansive Subgrade

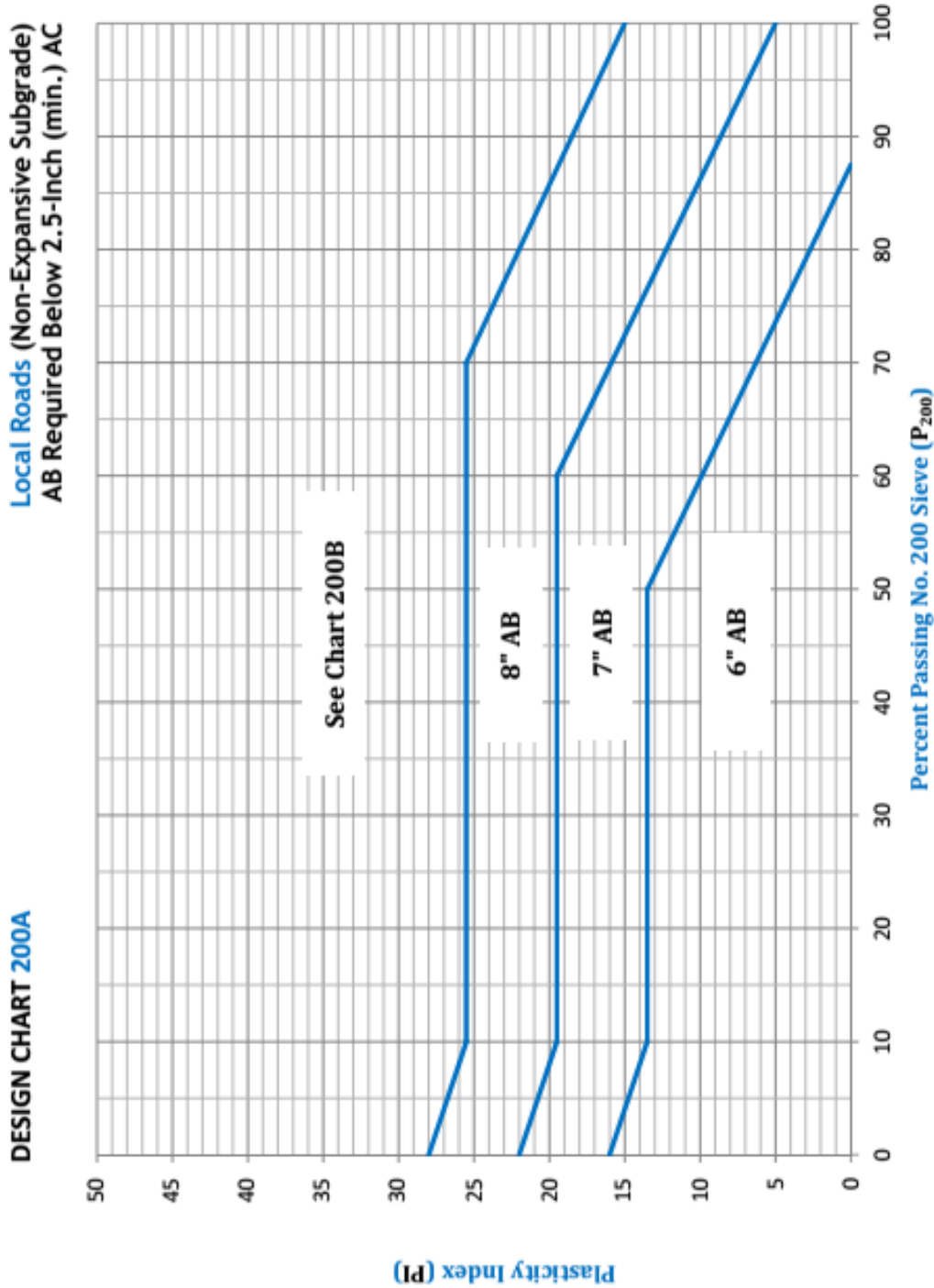

- NOTES:**
- (1) AB = Aggregate Base course (MAG 702.2).
 - (2) CLSS = Cement or Lime Stabilized Subgrade (MAG 311 or 309).
 - (3) Subgrade for all curb, gutter, and attached sidewalk shall be stabilized to match stabilization depth of pavement section.
 - (4) This detail is also applicable for industrial/commercial roads with 4" (minimum) of asphalt concrete.

DESIGN CHART 200B

Depth of Aggregate Base for Local Roads
Expansive Subgrade

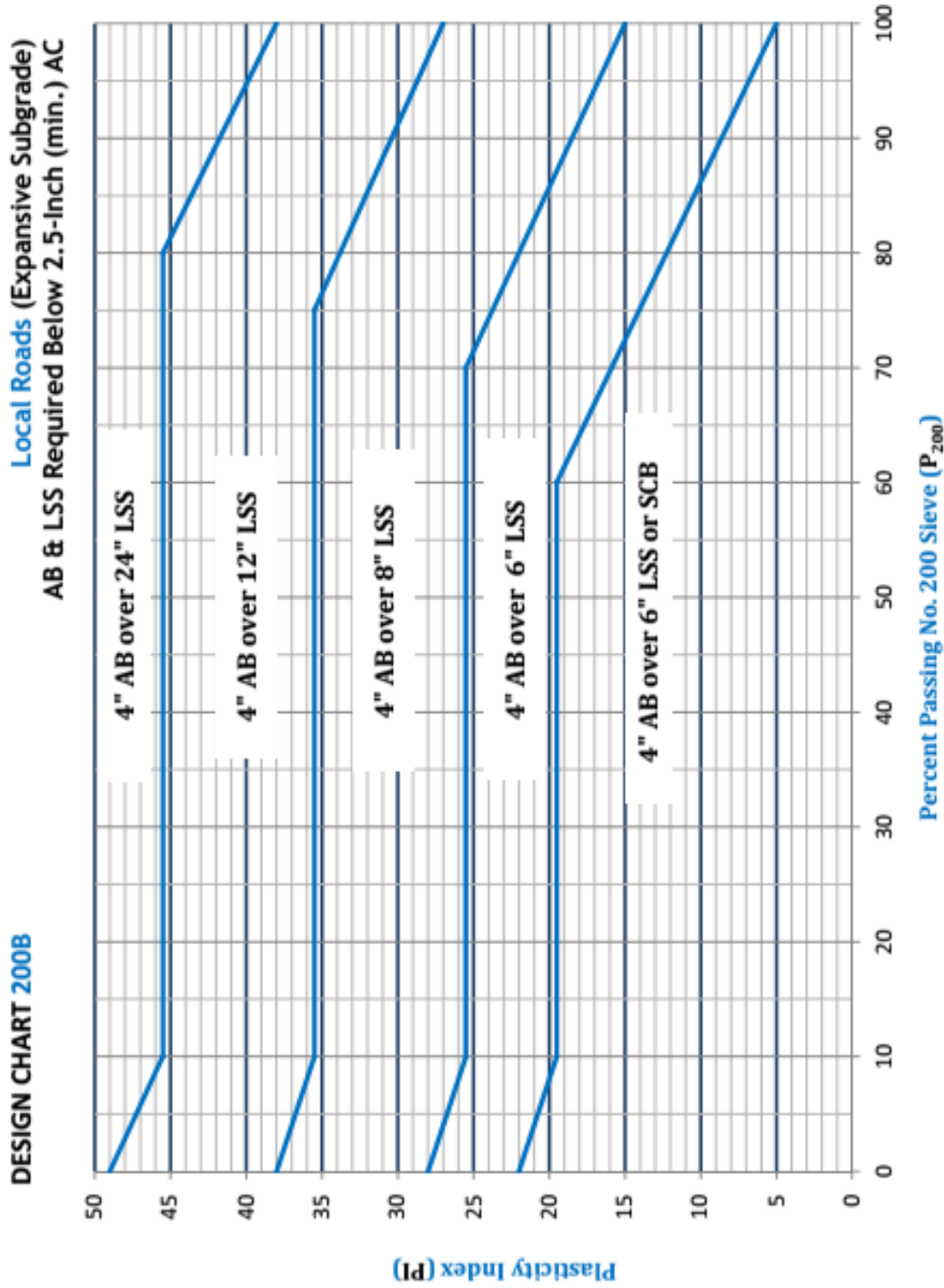

10.2.6 RIGID PAVEMENT DESIGN

Rigid pavement (Portland Cement Concrete Pavement) sections can occasionally be designed for City roadways when the flexible pavement sections are not adequate for certain situations. For example, concrete pavement sections are used on bus bays or when the truck percentage on a road section is relatively high.

Rigid pavement design shall be in accordance with the procedure shown in Chapter 2 of the latest revision of ADOT Pavement Design Manual¹. The basic design equation for rigid pavements given in ADOT's manual is:

$$\log_{10}(W_{18}) = Z_R S_0 + 7.35 \log_{10}(D + 1) - 0.06 + \frac{\log_{10}\left(\frac{\Delta\text{PSI}}{4.5 - 1.5}\right)}{1 + \frac{1.624 \times 10^7}{(D + 1)^{8.46}}} + (4.22 - 0.32 p_t) \log_{10} \left[\frac{S'_c C_d (D^{0.75} - 1.132)}{215.63 J \left(D^{0.75} - \frac{18.42}{(E_c/k)^{0.25}} \right)} \right]$$

Where,

- W_{18} = predicted number of 18-kip equivalent single axle load applications
- Z_R = standard normal deviate
- S_0 = combined standard error of the traffic prediction and performance prediction, equal to 0.35
- D = thickness (inches) of pavement slab, cannot be less than nine (9) inches
- S'_c = average modulus of rupture (psi) for Portland cement concrete used on a specific project, fixed at 670 psi
- p_0 = design initial serviceability index
- p_t = design terminal serviceability index
- ΔPSI = $p_0 - p_t$
- C_d = drainage coefficient same as flexible
- J = load transfer coefficient used to adjust for load transfer characteristics of a specific design
- E_c = modulus of elasticity (psi) for concrete. It can be estimated from concrete compressive strength f'_c :

$$E_c = 57000(f'_c)$$

- k = modulus of subgrade reaction is found by first determining the subgrade Resilient Modulus, M_R (see flexible pavement design). For full depth design M_R can be converted to k value with the following formula:

$$k = \frac{M_R}{19.4}$$

QUICK REFERENCE

Pavement Design Procedures

- A. Standard Analysis Period: 20 Years
- B. Directional Distribution: $D_D = 0.5$ to 0.7 (normally 0.5)
- C. Lane Distribution: D_L

Number of Lanes in Each Direction	Percent of 18-kip ESALs in Design Lane (D_L)
1	100
2	90
3	70
4	60

- D. Reliability:

Functional Classification ^a	Reliability	Z_R Value	Std. Dev. (S_0)
Highways and Parkways	95 %	-1.645	0.45
Arterials & Industrial	95 %	-1.645	0.45
Collectors	90 %	-1.282	0.45
Residential (Local)	80 %	-0.841	0.45

^a See Chapter 2 for *Functional Classification* Definitions.

- E. Serviceability:

Functional Classification ^a	P_0	P_t	Δ_{PSI}
Highways and Parkways	4.6	2.7	1.9
Arterials & Industrial	4.5	2.5	2.0
Collectors	4.4	2.3	2.1
Residential (Local)	4.2	2.0	2.2

^a See Chapter 2 for *Functional Classification* Definitions.

- F. Overall Standard Deviation: $S_0 = 0.45$
- G. Soil Resilient Modulus (refer to formulas in Section 10.2.2)

H. Structural Layer Coefficient:

Material Description	Structural Layer Coefficient, a_i	Thickness Constraint
Asphalt Rubber Asphalt Concrete (ARAC)	0.42 ^a	Minimum 1.5 in. ^b Maximum 2.0 in.
Asphalt Concrete (AC)	0.42	Based on Layered Analysis
Cement Treated Base (CTB)	0.28	Minimum 4.0 in.
Aggregate Base (AB)	0.12	Minimum 4.0 in.
MAG Select	0.11	Minimum 4.0 in.
Stabilized Subgrade	0.16 to 0.23 ^c	Minimum 6.0 in.

^a In order to consider the superior performance in resistance to cracking and other aging characteristics, a structural layer coefficient of 0.61 may be used for ARAC only for 1.5-in. thickness (as specified in MAG Sections 325 and 717) when used as a surface course on top of 3 inches or greater of conventional asphalt pavement (as specified in MAG Sections 321 and 710).

^b Minimum thickness can be reduced to 1.0 inch for hot-in-place recycling (HIPR) pavement construction.

^c The coefficient for stabilized subgrade is to be determined using a non-soaked 7-day compressive strength, using ASTM D1633 Method A, and the following formula:

$$a_i = 0.15 + 0.0001 (\text{CSCLS})$$

Where: CSCLS = Compressive strength of cement or lime stabilized subgrade in psi.

I. Drainage Coefficient:

Drainage Quality	Drainage Coefficient ADOT ¹	Water Removed Within AASHTO ² , page II-22
Excellent	1.15	2 hours
Good	1.07	1 day
Fair	1.00	1 week
Poor	0.93	1 month
Very Poor	0.86	Water will not drain

J. Expansion Potential:

Expansion Potential	Recommended Treatment
< 2%	None
2% to 5%	Stabilize ^a in place to a depth of 6 inches
> 5%	Stabilize ^b with lime to a depth of 12 inches

^a The soil can be stabilized with either lime, cement or lime/cement combination by specifying the requirements of MAG Section 309 Lime Slurry Stabilization or MAG Section 311 Soil Cement Base Course. For either method, a minimum compressive strength of 160 psi shall be achieved when tested as required by the specifications.

^b The soil should be stabilized with lime in at least two layers following the requirements of MAG Section 311. The bottom layer can be stabilized in place.

10.3 SPECIFICATIONS

The preliminary pavement design report shall provide descriptions of each of the materials used in the design. Final pavement design reports shall have a list (can be part of the cost estimate) of the pavement construction items to be used. Specifications shall be provided for any materials or processes to be used that are not included in MAG Standards.

Pavement designs that have a possibility of requiring fill beneath the roadway shall include a section describing the requirements for the soils to be allowed in the fill. The “Subgrade Acceptance Chart” developed by ADOT is one method of identifying soil requirements for pavements. These charts are discussed in ADOT Pavement Design Manual¹.

If expansive soils are encountered in subgrade soils, final pavement design reports shall include a construction specification that describes the recommended remedy. Such specifications shall address treatment of soils beneath curb, gutter and sidewalk as well as pavements, and shall clearly state that the specification applies to soils beneath curb, gutter, and sidewalk.

10.4 CHAPTER REFERENCES

¹Arizona Department of Transportation (ADOT) *Pavement Design Manual*, Arizona Department of Transportation, Phoenix, Arizona September 2017.

²American Association of State Highway and Transportation Officials (AASHTO) *AASHTO Guide for Design of Pavement Structures*, Association of State Highway and Transportation Officials, Washington D. C. 1993.

³*Implementation of the AASHTO Mechanistic-Empirical Pavement Design Guide and Software*, National Cooperative Highway Research Program (NCHRP), 2014.

⁴Arizona Department of Transportation (ADOT) *Materials Preliminary Engineering and Design Manual*, Arizona Department of Transportation, Phoenix, Arizona March 1989.

⁵Federal Aviation Administration (FAA) Advisory Circular No. 150/5320-6E *Airport Pavement Design and Evaluation*, United States Department of Transportation, Washington, D.C. Dated 9/30/2009.

⁶Arizona Department of Transportation (ADOT) *Materials Testing Manual*, Arizona Department of Transportation, Phoenix, Arizona November 2, 2016.

EXHIBIT B

ARTICLE 151.04 SUPPLEMENTARY DISTRICT REGULATIONS

Sections:

- 151.04.001 Purpose
- 151.04.002 Buildings Under Construction
- 151.04.003 Moving of Buildings
- 151.04.004 Exceptions to Height Limitations
- 151.04.005 Administrative Modification of Dimensional Standards
- 151.04.006 Projections Into Required Yards in Residential Districts
- 151.04.007 Yards and Setbacks, General Usage
- ~~151.04.008 Clear Vision Area~~
- 151.04.00~~8~~⁹ Fences and Walls
- 151.04.00~~9~~¹⁰ Swimming Pools
- 151.04.01~~0~~¹ Unsuitable Land
- 151.04.01~~1~~² Grading Requirements
- 151.04.01~~2~~³ Required Drainage Facilities
- 151.04.01~~3~~⁴ Parking of Miscellaneous Vehicles and Trailers in Residential Districts

Section 151.04.001 Purpose

The provisions of this Article establish standards and regulations for on-site development of all lots within the City.

(Ord. 743, passed 4-10-86)

Section 151.04.002 Buildings Under Construction

Nothing in this Code shall be deemed to require a change in the plans, construction, or designated use of any building on which actual construction was lawfully begun prior to the effective date of this Code and upon which actual building construction has been diligently carried forth. Actual construction is defined to include the placing of construction materials in the permanent location and fastened in permanent manner; except that where demolition or removal of an existing building has been substantially begun to prepare for rebuilding, such demolition or removal shall be deemed to be actual construction.

('76 Code, Art. 12-1) (Ord. 743, passed 4-10-86)

Section 151.04.003 Moving of Buildings

No building or structure, which has been wholly or partially erected on any premises, shall be moved to or be placed upon any other premises until a permit for the removal

and relocation has been issued by the Director of Community Development. Any such building or structure shall conform to all provisions of this Code in the same manner as a new building or structure.

No such building or structure shall be used or occupied until a Certificate of Occupancy has been issued, as provided in Section 151.03.005 of this Code.

('76 Code, Art. 12-1) (Ord. 743, passed 4-10-86)

Section 151.04.004 Exceptions to Height Limitations

Height regulations established elsewhere in this Code shall not apply to the following:

- A. In any zoning district - church spires, belfries, cupolas, and domes that are not built for human occupancy; monuments; water towers; flagpoles; non-commercial radio or television antennas; and star watch equipment;
- B. In commercial or industrial zoning districts - parapet walls extending not more than 4 feet above the height of the building and any elevator housings;
- C. In industrial districts - chimneys, smokestacks, derricks, and conveyors; to grain elevators or similar structures used in the industrial processes.

('76 Code, Art. 12-1) (Ord. 743, passed 4-10-86; Am. Ord. 2010-017, passed 9-23-10; Am. Ord. 2019-007, passed 11-14-19)

Section 151.04.005 Administrative Modification of Dimensional Standards

A. Applicability

1. In accordance with the provisions of this Section, staff may modify a required building setback in cases where the following conditions apply:

a. For properties located outside the Infill Incentive District Area:

- (1) The subject property contains an existing single-family dwelling unit; and
- (2) The modified setback results in a building setback of no less than five feet from a rear or side property line unless the subject property abuts a platted alleyway or dedicated drainageway in which case a modified setback shall provide no less than one-foot of building setback from a rear or side property line that abuts a platted alleyway or dedicated drainageway.

b. For properties located inside of an Infill Incentive District Area:

- (1) The subject property is used or proposed to be used for residential purposes; and

(2) The modified setback results in a building setback of no less than five feet from a rear or side property line unless the subject property abuts a platted alleyway or dedicated drainageway in which case a modified setback shall provide no less than one-foot of building setback from a rear or side property line that abuts a platted alleyway or dedicated drainageway.

(3) The modified setback results in a building setback of no less than fifteen feet from a front lot line adjoining the primary frontage or no less than ten feet from a front lot line adjoining the secondary frontage (on corner lots); provided, however, no setback modification shall be granted for that portion of a front facade containing an enclosed garage or carport.

2. In accordance with the provisions of this Section, staff may modify the maximum fence or wall height on properties used for residential purposes, provided however, any existing wall proposed to be elevated shall be certified by a professional engineer or architect registered in the State of Arizona as being able to support the modification in accordance with local building codes.

B. Application. Requests shall be made on application forms provided by the Department of Community Development.

C. The City shall notify, by mail, the property owner(s) most affected by the proposed request. The notice shall include a sketch plan of the site.

D. Standards. The City shall grant a modification of the setback after these following standards have been met:

1. The request shall not substantially reduce the amount of privacy that would otherwise be enjoyed by nearby residents. This is determined by the responses from adjacent property owners and staff observations.

2. Significant views of prominent land forms or parks from nearby properties will not be obstructed any more than would occur if the request was granted.

3. Traffic visibility on adjoining streets will not be adversely affected;

4. Drainage from proposed buildings and structures will not adversely affect adjoining properties and public rights-of-way;

5. The location of proposed buildings and structures, and the activities to be conducted therein, will not impose objectionable noise levels or odors on adjoining properties.

6. The proposal will not interfere with the daily living activities or injure the rights of adjacent property owners. This is determined by the responses from the adjacent property owners and staff observations.

E. Determination by the City

1. The City shall review all the submitted information and provide a written response to the petitioner of the action.

2. The City shall approve the application if all the standards as stated in 151.04.006 .D are met. Once granted, the building permit may be issued. The permit must be issued within 120 days of the granting of the request. Approval of the request does not set precedent; each request is reviewed on an individual basis.

3. The request shall be denied if the standards as stated in 151.04.006 .D are not met. The decision shall indicate the reasons why the request was denied.

F. Fees. Fees for administrative modifications shall be determined according to a schedule established by the Council.

G. Appeals to the Hearing Officer. Any aggrieved person may appeal the decision of the City to the Hearing Officer, which will be heard in accordance with Section 151.30.008 . Upon filing an appeal, the applicant shall pay a filing fee established by the Council.

(Ord. 2004-013, passed 11-9-04; Am. Ord. 2010-017, passed 9-23-10; Am. Ord. 2018-002, passed 2-8-18; Am. Ord. 2019-007, passed 11-14-19)

Section 151.04.006 Projections into Required Yards in Residential Districts

A. Ground-mounted, suspended- or window-type air conditioning units, evaporative coolers, or forced-air furnaces and swimming pools, spa or hot tub equipment, or other similar equipment may project over or onto any required side or required rear yard provided that they are not closer than 2 feet to any lot line when installed.

B. Awnings, open fire balconies, and fire escape stairs may project not more than 5 feet over any required yard provided that they are not closer than 2 feet to any lot line when installed.

C. Cornices and eaves may project not more than 3 feet over any required yard provided that they are no closer than 2 feet to any lot line.

D. Sills, leaders, belt courses, and similar ornamental features may not project more than 6 inches over or into any required yard. A chimney or pilaster may project not more than 18 inches into any required yard provided that it is not more than 8 feet in width.

E. Bay or greenhouse windows, whether supported on their own foundations or not, may project not more than 2 feet over or into any required yard provided that they are not more than 8 feet in width on the outside plane of the bay.

F. Unroofed terraces, patios, steps, or similar features may not extend over 3 feet above grade when projecting into any required yard.

(’76 Code, Art. 12-1) (Ord. 743, passed 4-10-86; Am. Ord. 896, passed 1-23-92 ; Am. Ord. 2019-007, passed 11-14-19)

Section 151.04.007 Yards and Setbacks, General Usage

A. Except as provided elsewhere in this Code, no compressor unit, condensing unit, cooling tower, evaporative condenser, or similar device located on the ground shall be located closer to any interior lot line than the minimum setback required for the main building. All such devices shall discharge air in a direction other than toward any lot line within 25 feet of such device.

B. Where future street lines have been officially established by the Council, all required setbacks shall be measured from future property lines.

C. Satellite antennas shall not be erected in the required front or side yards.

('76 Code, Art. 12-1) (Ord. 743, passed 4-10-86 ; Am. Ord. 2019-007, passed 11-14-19)

Section 151.04.008 Clear-Vision Area

~~A. Clear-Vision Areas at Street Intersections. Development shall be setback or restricted near certain street intersections in order to provide a minimum clear-vision area. Clear-vision areas shall be determined for each controlled street intersecting a thru or uncontrolled street. The determination of the clear-vision area for each controlled street shall be made according to Diagram 1 using the minimum corner sight distance listed in Table A.~~

-

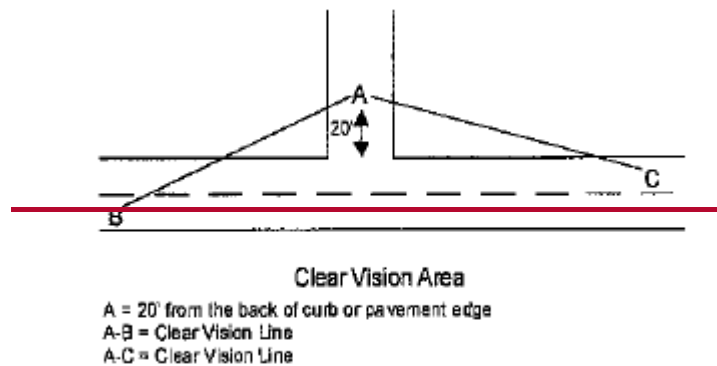

TABLE A

**MINIMUM CORNER SIGHT DISTANCE
BY TYPE OF STREET OR DESIGN SPEED**

-

<i>Type of Through Street</i>	<i>Design Speed</i>	<i>A-B, A-C Distance in Feet</i>
Principal Arterial		

Major Arterial		
Minor Arterial		
Collector		
Local		
<p>Note: To determine corner sight distance for speeds not included in this table, multiply the speed by 10 to calculate the distance.</p>		

-

~~B. Clear Vision Areas at Driveways. Clear vision areas at driveways, including private driveways to public streets in residential, commercial, or industrial districts shall have a minimum clear vision area as determined by Diagram 1 and Table A. For driveways, point A shall be no closer than 10 feet behind the curb of the public street being accessed.~~

~~The clear vision area for each driveway shall be illustrated on every site plan submitted to the City for approval.~~

~~C. Obstructions in the Clear Vision Area. There shall be no fence, structure, wall, or sign, higher than 3 feet and no landscaping between a height of 3 feet and 8 feet within the Clear Vision Area for driveways, alleys, and street intersections. Obstructions in the Clear Vision Area for residential driveways shall not be regulated. The height shall be measured from the top of the curb, or where no curb exists, from the established street centerline grade.~~

~~D. The preceding provisions shall not apply to the following:~~

- ~~—1. A public utility structure;~~
- ~~—2. A supporting member or appurtenance to a permanent building lawfully existing on the date this standard becomes effective and permitted as a non-conforming structure as provided by Section 151.24.002.G;~~
- ~~—3. An official warning sign or signal;~~
- ~~—4. A place where the natural contour of the ground is such that there can be no cross-visibility at the intersection.~~

~~(’76 Code, Art. 12-1) (Ord. 743, passed 4-10-86; Am. Ord. 764, passed 1-8-87; Am. Ord. 854, passed 1-25-90; Am. Ord. 2010-017, passed 9-23-10 ; Am. Ord. 2019-007, passed 11-14-19)~~

Section 151.04.0089 Fences and Walls

A. A fence or wall may be erected in any residential zoning district if it meets the following requirements:

1. Maximum height and setback requirements: (measured from highest grade on either side of the fence):

a. In a side and rear yard setback, the maximum height of a fence or wall shall not exceed 6 feet except for the following:

(1) A fence or wall can be constructed 8 feet above grade within the buildable area of the principal structure as long as all requirements of the International Building Code are met.

(2) Medical Marijuana Cultivation Facility walls shall be constructed 10 feet above grade within the buildable area of the principal structure as long as all appropriate requirements of the International Building Code and the Arizona Department of Health Services are met.

b. Additional height can be requested by applying for the Administrative Modification process as described in Section 151.04.005, Administrative Modification;

c. In a front yard setback, the maximum height of an opaque fence or wall shall not exceed 4 feet on properties less than 10,000 square feet or shall not exceed 5 feet on properties larger than 10,000 square feet;

d. No opaque fence or wall exceeding 3 feet high shall be erected in the clear-vision area of a driveway, alley, or intersection;

e. All fences and walls are to be constructed on private property and out of any public right-of-way, public drainageways, and publically dedicated easements.

B. No fence on the exterior of the property shall contain barbed wire, razor ribbon, electrical current or charge of electricity, broken glass, or similar hazardous materials or devices. However, fences in commercial or industrial districts which enclose storage areas, transformers, antennae, or other high value or dangerous installation areas may have barbed wire or razor ribbon connected so long as they are located more than 6 feet above grade. Where the keeping of livestock is permitted, barbed wire is allowed.

C. Every fence shall be maintained in a condition of reasonable repair and shall not be allowed to become and remain in a condition of disrepair. Any fence that is or has become dangerous to public safety, health, or welfare shall be considered a violation of this Code.

('76 Code, Art. 12-1) (Ord. 743, passed 4-10-86; Am. Ord. 764, passed 1-8-87; Am. Ord. 934, passed 10-28-93; Am. Ord. 2003-014, passed 8-14-03; Am. Ord. 2010-017, passed 9-23-10; Am. Ord. 2011-004, passed 5-12-11 ; Am. Ord. 2019-007, passed 11-14-19)

Section 151.04.009~~10~~ Swimming Pools

A. No swimming pool or other body of water intended for bathing 2 feet or greater in depth and longer than 4 feet in the largest linear dimension shall be located in any required front or side yard nor shall any such pool or body of water intended for bathing be closer than 4 feet to any lot line.

B. Whether it is accessory to a residential or a business use, every swimming pool or body of water intended for bathing 2 feet or greater in depth and longer than 4 feet in the largest linear dimension shall be enclosed by a fence, wall, or other structure in conformance with the provisions of the International Building Code.

C. Under no circumstances shall a pool intended for bathing be drained into an alley or other public right-of-way except that draining to a street or alley capable of carrying the run-off may be authorized by permit from the City. The Director of Community Development may permit the use of an on-site dry well for pool drainage. Any such dry well shall be subject to the requirements of A.R.S. §§ 49-331 through 336, which requires a permit from the ADHS (Arizona Department of Health Services) and any provisions contained in Section 151.22.029, Flood Hazard.

D. Any structure built over a swimming pool or body of water intended for bathing, whether rigid, semi-rigid or inflatable is considered to be an accessory structure as defined in Section 151.02.004 and must meet the requirements of the adopted International Building Codes. Plans must be submitted to the Department of Community Development for approval prior to commencement of initial construction.

E. New swimming pools, spas, and hot tubs shall be required to have a cover. The permit application shall note the type of cover proposed. Covers shall be of a solid (not mesh) design.

('76 Code, Art. 12-1) (Ord. 743, passed 4-10-86; Am. Ord. 764, passed 1-8-87; Am. Ord. 874, passed 1-10-91; Am. Ord. 896, passed 1-23-92; Am. Ord. 2003-005, passed 2-13-03; Am. Ord. 2005-010, passed 6-9-05 ; Am. Ord. 2019-007, passed 11-14-19)

Section 151.04.010~~4~~ Unsuitable Land

Property may not be developed if, in the opinion of the City, based on the written recommendation of the Director of Community Development, the land is unsuitable for the proposed use by reason of adverse topography, adverse soils, earth surface subsidence, high water table, periodic flooding, lack of water, or other natural or man-made hazards to life. However, the City may approve development of such land upon receipt of evidence from the developer's professional engineer's justification acceptable to the Director of Public Works that the construction of specific improvements can be expected to render the land usable, in which case, construction upon such land shall be prohibited until the specified public improvements have been designed by the developer's professional engineer, approved by the City Engineer, and construction has been guaranteed.

(Ord. 743, passed 4-10-86; Am. Ord. 875, passed 1-10-91; Am. Ord. 1043, passed 9-11-97 ; Am. Ord. 2019-007, passed 11-14-19)

Section 151.04.01~~1~~² Grading Requirements

A. Cuts. Cut slopes shall not exceed in steepness a 3:1 (horizontal to vertical) ratio unless recommended by a certified soils engineer and approved by the City Engineer. Slopes between 3:1 and 4:1 ratio shall receive an approved slope treatment such as dumped rip rap, grouted rip rap, or concrete. Slopes flatter than 4:1 may require a slope treatment such as hydroseeding, decomposed granite, or as determined by the City Engineer. Slopes flatter than 4:1 and located in the public right-of-way shall require a slope treatment such as hydroseeding, decomposed granite, or as determined by the City Engineer.

B. Fill. Fill slopes shall not exceed in steepness a 4:1 (horizontal to vertical) ratio. All fills shall receive an approved slope treatment such as hydroseeding, decomposed granite, or as determined by the City Engineer.

1. Ground Preparations. The ground surface shall be prepared to receive fill by removing vegetation, noncomplying fill, top soil and other unsuitable materials; scarify to provide a bond with new fill and where slopes are steeper than 15 percent and the height is greater than 5 feet, by benching into a competent material as determined by a certified soils engineering report and approved by the City Engineer.

2. Structural Fill Material. Detrimental amounts of organic material shall not be permitted in structural fills. Burial of tree stumps will not be allowed on any site other than an approved solid waste disposal site. No rock or similar material greater than 6 inches in diameter shall be placed in a structural fill. The City Engineer may permit placement of larger rock if the soils engineering report devises a method to continuously inspect placement and certify stability of rock disposal areas having no overlapping with physical improvements, and is a minimum of 5 feet below grade measured vertically.

3. Structural Fill Compaction. Structural fill will be compacted to a minimum of 95 percent of maximum density. The soils engineer shall certify all structural fills as meeting minimum bearing capacity for the intended use and meeting minimum compacted density of 95 percent.

4. Non-Structural Fills. Fill materials and landscape berms will be compacted to at least 90 percent maximum density by reasonable mechanical means.

(Ord. 743, passed 4-10-86; Am. Ord. 875, passed 1-10-91; Am. Ord. 1043, passed 9-11-97; Am. Ord. 2008-010, passed 5-8-08; Am. Ord. 2010-017, passed 9-23-10 ; Am. Ord. 2019-007, passed 11-14-19)

Section 151.04.01~~2~~³ Required Drainage Facilities

A. All roof and foundation drains may be discharged either to:

1. a street or an alley, or
2. a public or approved private storm drain, or
3. a natural drainageway, if adjacent to the lot, or
4. to an on-site storage facility.(i.e. rain storage tank)
5. to depressed landscaped areas with a sufficient buffer from building foundation.
6. other as approved by the City Engineer.

B. The design of drainage facilities that involve discharges to a public works improvement or public property shall be reviewed and approved by the Director of Public Works prior to issuance of a building permit by the Director of Community Development. The Director of Community Development may permit the use of an on-site detention, retention, or dry well located in the rear yard for such drainage, provided the design is reviewed and approved by the Director of Public Works. Any such dry well shall be subject to the requirements of A.R.S. §§ 49-331 through 336 which requires a permit from the ADEQ. See Section 151.22.029, Flood Hazard, for applicable provisions when location of dry wells falls within the flood prone area.

C. Subsurface drainage facilities may be required in areas of fill if it is determined by a geologist or certified soils engineer that there will exist a groundwater situation that could cause stabilization problems. Any subsurface natural spring or field tile shall be piped to an approved drainage facility.

(Ord. 743, passed 4-10-86; Am. Ord. 764, passed 1-8-87; Am. Ord. 875, passed 1-10-91; Am. Ord. 1043, passed 9-11-97 ; Am. Ord. 2019-007, passed 11-14-19)

Section 151.04.01~~3~~⁴ Parking of Miscellaneous Vehicles and Trailers in Residential Zoning Districts

A. In residential zoning districts, no recreational vehicles, boat trailers, horse trailers, and similar trailers shall be parked or stored so as to interfere with the clear vision area as described by Section 151.04.009 or project into any right-of-way. No such vehicle so parked or stored shall be used for living purposes for more than 14 consecutive days.

B. No commercial or industrial type equipment to include: tractors, backhoes, bulldozers, trenchers, cranes, or other similar equipment, may be parked in an area visible to the public for more than 48 hours in any residential zoning district except when the equipment is being used for construction purposes on the site.

(Ord. 743, passed 4-10-86; Am. Ord. 982, passed 5-25-95 ; Am. Ord. 2019-007, passed 11-14-19)

Editor's notes:

Am. Ord. 2016-002, passed 2-25-16, renamed Article from General Regulations to Supplementary District Regulations.

Am. Ord. 2016-002, passed 2-25-16, removed Section 151.04.017 and relocated text to Section 151.06.003.

Am. Ord. 1086, passed 2-11-99. Amended Section 151.04.018. Language subsequently removed and relocated to Section 151.06.008 per Am. Ord. 2016-002, passed 2-25-16.

ARTICLE 151.08 PUBLIC IMPROVEMENT STANDARDS

Sections:

- 151.08.001 Purpose
- 151.08.002 General Regulations
- ~~151.08.003 Street Improvements Criteria~~
- ~~151.08.004 Street Design Standards~~
- ~~151.08.005 Street Access Standards~~
- 151.08.0036 Water Facilities
- 151.08.0047 Sewerage Facilities
- 151.08.0058 Surface Drainage and Storm Sewer Systems
- 151.08.0069 Easement Planning
- 151.08.00740 Streetlight Design and Construction
- 151.08.00844 Utility Trench Backfill Requirements
- 151.08.00942 Bus Bench/Bus Shelter Requirements
- 151.08.0103 Wireless Communications Facilities

Section 151.08.001 Purpose

It is the purpose of this article to define the responsibility of the developer or subdivider and the City in the planning, construction, and financing of public improvements, to establish the minimum acceptable standards and required public improvements for developments or subdivisions and to establish procedures for review and approval of engineering plans.

~~Further, it is the purpose of the Access Section to coordinate development of land uses to minimize hazards, prevent traffic congestion, preserve the traffic carrying capacity of arterial and collector streets, provide a suitable location of land uses, and minimize impacts of development.~~

The City is committed to environmental responsibility and shall encourage innovative sustainable solutions to design and infrastructure development whenever the public's health, safety, and welfare is advanced through such approaches. It shall be the responsibility of

the developer or subdivider to demonstrate that, where sustainable approaches are being utilized, improvements are constructed that are minimally equivalent to traditional design and are ideally superior.

('76 Code, Art. 12-1) (Ord. 743, passed 4-10-86; Am. Ord. 2012-004, passed 6-28-12)

Section 151.08.002 General Regulations

Responsibility for Improvement. The developer or subdivider is responsible for financing, planning, designing and constructing all public improvements to City

standards in the public right-of-way. Public improvements shall be defined as but not limited to: streets and alleys, curbs and gutters, sidewalks, multi-use paths, striping, street signs, drainage facilities, sewage disposal facilities, street lights, fire hydrants, water facilities, landscaping, and all other public improvements required by the City, this article, [the Maricopa County Roadway Design Manual as amended by the City of Sierra Vista](#), or the Arizona Revised Statutes.

Certain public improvements can be offset with the payment of Development fees as stated in the City of Sierra Vista Development Fee Study, and as defined in this Article.

All submittals shall be made to the Community Development Department.

A. Public Works Improvement Plans Required

1. The developer or subdivider shall be responsible for having a registered professional engineer in the State of Arizona prepare a complete set of public works improvement plans, for the construction of public improvements, when required, which are satisfactory to the City Engineer.

2. Public works improvement plans submitted in accordance with the provisions of Sections 151.18 or 151.19 shall be reviewed and approved by the City [as prescribed by those sections](#). Improvement plan checklists can be obtained from the City website.

The public works improvement plans must be stamped "Approved for Construction" by the City Engineer before any right-of-way permits may be issued or construction commences.

3. The City of Sierra Vista has delegation authority from the Arizona Department of Environmental Quality (ADEQ) to approve water and sewer infrastructure. If the City of Sierra Vista is to perform ADEQ review, applications shall be submitted with the final improvement plans. Blank applications can be obtained at the City website.

~~B. Landscape Improvement Plans Required~~

~~—Landscaping plans for plantings, irrigation, and related improvements in the public right of way shall be submitted in accordance with the provisions of Section 151.15, 151.18, 151.19, the City of Sierra Vista official plant list, and the City of Sierra Vista public right of way landscape specifications.~~

C. Public Works Improvement Plans

[Roadway and street improvement plans, curb, gutter, and sidewalk plans, and landscaping and irrigation plans, are to be designed and submitted per the Maricopa County Roadway Design Manual as amended by the City of Sierra Vista.](#)

1. [Public Improvement Plans shall be submitted to the Community Development Department in an electronic format readable to the City.](#) ~~Three sets of Public Works Improvement Plans shall be submitted.~~

2. All specifications and references required by the City's construction standards and specifications shall be shown on the construction drawings. A ~~signed copy of the completed~~ Public Works checklist shall accompany all submittals for review.

3. Plans shall be drawn at a horizontal scale of 1" = 40' and a vertical scale of 1" = 4', or an appropriate scale approved by the City. Drawings shall be oriented so that north is at the top of the page. However, when the preceding requirement proves to be impractical, then north shall be oriented to the right side of the page. North and scale must be identified on all plans.

~~4. Profiles shall show existing and proposed elevations along center lines of all streets as well as the edge of any new and existing pavement and all gutter lines.~~

~~a. When a proposed street intersects an existing street(s), the drawings shall show the elevations within a 200-foot radius of the intersection at the centerline.~~

~~b. Existing grades shall be shown on 25-foot intervals and new grades on 50-foot intervals.~~

45. Plans and profile sheets shall show the following information:

~~a. The locations and typical cross-section of street pavements including curbs and gutters (both sides), sidewalks, drainage easements, rights-of-way, manholes, light poles, and catch basin inlets.~~

~~b. The locations of street trees and the location of replacement trees for those to be removed during development.~~

a.e. The location, size, direction of flow, and invert elevations of existing and proposed sanitary sewers, storm water system, and fire hydrants.

b.d. A blue stake alert and reference any other utility/improvement plans.

c.e. Radii of all curves, lengths of tangents, and central angles on all streets shall be shown.

56. Sanitary sewerage and water systems shall be shown on the same set of drawings. A separate detailed water plan shall also be submitted. Water plans shall be stamped "approved" by the Water Company before they will be reviewed by the City Engineer.

67. Location, size, elevation, and other appropriate description of any existing or proposed facilities or utilities shall be shown on the drawings. In addition, all elevations shall be referred to the City's local datum.

78. Title, name, address, stamp, registered seal, signatures of the engineer and surveyor, and date, including revision dates, shall be shown on the drawings.

D. Improvement Standards. All required public works improvements shall be designed and constructed in accordance with the latest revision of the Uniform Standard Specifications for Public Works Construction and the Uniform Standard Details for

Public Works Construction as compiled by the Maricopa Association of Governments (MAG), and the City of Sierra Vista Public Works Engineering Design Standards and Drawings, as modified and adopted by the Council. Other standards pertaining to any required improvements shall be approved by the City.

E. Inspection and Testing of Public Works Improvements

1. All public works improvements constructed in the public right-of-way shall be constructed to the standards above and are subject to the inspection and approval of the City Engineer. Construction in any public right-of-way, public easement, and/or public drainageway shall not be commenced until a right-of-way permit has been issued by the City Engineer for such construction; and if work has been discontinued for any reason, it shall not be resumed until approval has been obtained from the City Engineer.

A maintenance and construction bond may be required with the right-of-way permit application if the project estimated cost exceeds \$5,000 as stated in Section §91.23 of the City Code.

Formatted: Font: (Default) Arial

Formatted: Font: (Default) Arial

2. The ~~permittee~~ ~~developer~~ shall be responsible for having a person who is authorized and certified under Arizona Revised Statutes (ARS) to perform quality control materials testing and conduct the testing of all materials used in the construction of public works improvements. Any failed quality assurance testing performed by the City shall be paid by the Developer.

3. The results of all tests conducted during construction shall be provided to the City Engineer prior to the final inspection.

F. Acceptance of Public Improvements.

1. Required public improvements for subdivision plats shall be constructed and accepted in accordance with Section 151.19.

2. For all other applications for which public improvements are required, ~~Once~~ all items in this section are submitted and, ~~upon due notice from the developer of the~~ ~~permittee has presumptive~~ completion of all public improvements as called for on the approved plans and ~~as~~ required under ~~the provisions of~~ this Code, the City will make a final inspection. If the improvements fail inspection, the permittee will replace, correct, and/or reconstruct the deficient improvements within 30 days or as directed by the City Engineer. Failure to make the required corrections will result in forfeiture of stated security.

3. If all construction is completed to the City's satisfaction, ~~this inspection shall constitute the final inspection and~~ the Director of the Department of Community Development will recommend to Council, by Resolution, the final acceptance of the public improvements for maintenance, provided the following items are submitted:

a. ~~1.~~ Final As-Built Plans. The developer shall provide the City with an electronic copy of as-built improvement plans for inclusion in the City Base Map. The file(s) shall be compatible with the release of AutoCAD currently being used by the City or any additional electronically approved format. The as-built plans shall show all streets, drainage, sewer, and water improvements constructed within public rights-of-way or

public easements. Final as-built plans shall show the approved design conditions and reflect any field changes approved by the City Engineer and the developer's engineer. The developer's engineer shall certify that the final plans represent as nearly as possible the actual field conditions of all improvements as constructed. If the developer fails to provide the file(s), the City will duplicate the information from the plans and charge the developer for the time and materials required for the work.

b.~~2.~~ Developer's Guarantee and Waiver of Liens. The developer shall certify on the Developer's Guarantee and Waiver of Liens form that is provided by the City (available on the website) that all bills for labor and materials used in the work have been paid and agree to indemnify and save harmless the City against any and all liens, claims of liens, suits, actions, damages, charges, and expenses whatsoever, which the City may suffer arising out of the failure of the developer to pay for all labor performed and materials furnished in the construction of the required improvements. Also, the developer shall guarantee all public improvements work against defective workmanship or materials for a period of two years from the date of its final acceptance by the Council.

~~3. A security shall be provided to the City to substantiate the validity of the Developer's Guarantee. The amount of the security shall be \$200 per lot. The security shall be retained until the two-year warranty period has elapsed. The security shall consist of cash, a performance bond, a cash trust, or a certificate of deposit, which meets the requirements in Section 151.008.002(F), Improvement Security.~~

~~G. Noncompliance with Provisions Under Obligations~~

~~1. If the City finds that a developer is not complying with the obligations of the provisions of their subdivider's or development agreement or the requirements of this Code regarding the obligation, the City shall, in writing, provide notice to the developer and the surety, detailing the reasons of noncompliance. The Developer will be given 30 days in which to comply or make substantial progress towards complying with the provisions of their subdivision or development agreement. The City may allow additional time to complete the obligations at its discretion.~~

~~2. If the developer or the surety does not comply with or is not progressing toward fulfilling the obligation within the applied time frames, the City will notify, in writing that the developer has not fulfilled its obligation and may take the following action:~~

~~a. Enter the development site to carry out the obligation in accordance with the provisions agreed upon.~~

~~b. Proceed with releasing from the surety the funds payable to the City by the security instrument.~~

~~c. If the security for the obligation is a bond, notify the surety that has furnished the bond that reimbursement for the expense for fulfillment of the obligation is due and payable to the City. If the security is a deposit of cash or other assets, the City may appropriate as much of the deposit as is it deemed necessary to recoup the expense of fulfilling the developer's obligation.~~

~~—d. If a third party trust is used, take all necessary actions required by the agreement.~~

~~—3. If the bond or another security required by Section 151.08.002F is not sufficient to compensate the City for expenses necessary to fulfill the developer's obligation, the City will place a lien, in favor of the City, on property for the remaining amount due to the City.~~

~~—4. A Notice demanding the amount due to the City will be sent to the developer and surety and will be filed with the County Recorder thereby placing a lien on the real property. The notice shall include (1) the reason for the developer's failure to comply with the obligation, (2) the amount needed to compensate the City for their work in completing the developer's obligation, and (3) the amount needed to pay the City if the bond or security is insufficient to cover the entire cost.~~

~~—5. The lien may be foreclosed in the manner prescribed by law for foreclosing other liens on real property.~~

H. Dedication and Improvement

1. A developer shall dedicate to the public any right-of-way and or easements; submit ~~construct~~ any public improvements plans for review and approval; and construct ~~required public improvements; in accordance with the provisions of Section 151.08.003 and 151.08.004~~ whenever one or more of the following conditions occur:

a. When there is construction of residential, commercial, or industrial subdivisions, buildings, structures, or additions to existing structures.

b. When there is a change in land use or zoning that, in the opinion of the City, will result in an increase in traffic.

c. When directed by the Council by ordinance in accordance with ARS.

2. Exceptions:

a. The dedication of additional right-of-way may not be required if upon determination by the City Engineer that the dedication of additional right-of-way is not needed for the expansion of public improvements.

b. If an existing improvement was designed and constructed according to the City or County standards applicable at the time of construction. However, if the City determines the existing improvement poses a safety or health problem, does not meet current ADA requirements, or current minimum drainage standards, then dedication will be required.

c. Construction of public improvements, to include certain roadways and traffic signals, can be offset with the payment of Development Fees as stated in the City Code, Chapter 154, Development Fees. Developers may be eligible for site-specific credits or reimbursements only if they provide public improvements that have been included in the Transportation Development Fee and/or the Parks, Recreation, and Trails Development Fee calculation schedule per the City Code, Chapter 154,

Development Fees. Public improvements on Collector or Local roadways are not eligible for credits against development fees.

(’76 Code, Art. 12-1) (Ord. 743, passed 4-10-86; Am. Ord. 804, passed 3-24-88; Am. Ord. 834, passed 3-9-89; Am. Ord. 854, passed 1-25-90; Am. Ord. 875, passed 1-10-91; Am. Ord. 896, passed 1-23-92; Am. Ord. 925, passed 8-12-93; Am. Ord. 990, passed 10-26-95; Am. Ord. 996, passed 1-11-96; Am. Ord. 1043, passed 9-11-97; Am. Ord. 2003-005, passed 2-13-03; Am. Ord. 2012-004, passed 6-28-12; Am. Ord. 2020-003, passed 4-9-20)

~~Section 151.08.003 Street Improvements Criteria~~

~~A.—General Provisions. No development permit or subdivision approval shall be issued unless each lot in the development has frontage or approved public access to a public street. The public streets shall be dedicated and improved to the Street Design Standards of Section 151.08.004. Streets that are contiguous (existing or planned) with a development but reside in the county shall be constructed to minimum County construction standards. Roadways shall be minimum County half width right-of-way or 26 feet, whichever is greater. No development will be permitted when it will generate traffic beyond the street's current carrying capacity within a ¼ mile of the development including pavement width and signalization.~~

~~B.—Street Continuations. Street layouts shall provide for the continuation of existing and proposed Arterial and Collector Streets into adjacent areas and such other streets as the City may designate. If the City Engineer determines that construction of the full length of adjacent street improvement is unnecessary, said improvements may be deferred by written agreement and a security.~~

~~C.—Street Orientation. To plan for energy conserving orientation of future urban development, new streets shall be designed in an eastwest orientation to the extent possible. When topographic conditions or existing street layout make street design for good solar orientation difficult or undesirable, lots shall be laid out so that the units shall be oriented to the south to the greatest extent possible.~~

~~D.—Traffic Circulation Plan Conformance. Street alignment in the development will conform to the Traffic Circulation Plan or any adopted specific plans and will be built in accordance with the design standards for the designated street (Arterial, Collector, etc.). The City Engineer may recommend that Council approve minor deviations in alignment of a street when it is impractical to conform to the exact alignment shown on the Traffic Circulation Plan because of adverse topography, drainage problems, existing development, or traffic safety. The minor deviation must not affect the public purpose of the street and must maintain a not to exceed distance of 1,500 feet between an Arterial or Collector street and a parallel collector street.~~

~~E.—Half Width Streets. Half width streets shall be discouraged except when necessary to provide right-of-way required by the Traffic Circulation Plan, to complete a street pattern already begun, or to ensure reasonable development of the adjoining un-platted~~

parcels. Where an existing half-width street abuts a tract, the remaining half street shall be platted within the tract. The subdivider shall plat and develop a street of sufficient pavement width to accommodate two-way traffic (26-foot minimum).

F.—Maximum Block Length. The maximum block length shall be 1,500 feet, measured along the centerline of the street and between intersecting street centerlines.

G.—Crosswalks. Crosswalks shall not be installed unless a traffic engineering study determines that one is warranted per the MUTCD/ADOT and shall be installed per the same.

H.—Measurements. Unless otherwise noted, all street width measurements are to edge of pavement and all length measurements are along the centerline of the right-of-way and to the centerline of intersecting streets.

I.—Intersection Criteria

—1.—Streets intersecting an Arterial or Collector Street shall do so at a 90° angle. Local streets shall typically intersect at right angles but in no case less than 75° unless approved by the City.

—2.—Local streets intersecting a Collector street or Arterial street shall have a tangent section of center line at least 150 feet in length measured from the right-of-way line of the Major street, except that no such tangent is required when the local street curve has a center line radius greater than 600 feet.

—3.—Street jogs and commercial driveway accesses with centerline offsets less than 125 feet shall be avoided except when the City determines that vehicle conflicts do not exist.

—4.—Street intersections with more than four legs and Y-type intersections with legs meeting in acute angles shall be prohibited.

J.—Intersection Design and Construction

The approach of an intersection shall have a relatively level area with a grade of not more than 3 percent and not less than 0.75 percent for a distance required to provide adequate sight distance along both intersecting streets and across the corners of the intersection as defined by the City of Sierra Vista Development Code or AASHTO (American Association of State Highway and Transportation Officials), whichever is the most restrictive.

K.—Street and Alley Construction. All streets and alleys shall be graded and paved with Asphaltic Concrete or Portland Cement Concrete to standards approved by the City.

—1.—In no case shall the minimum pavement cross section be less than the following:

— a.—Arterials and Collectors Designated on Traffic Circulation Plan — 3 inches of asphaltic concrete over 10 inches of aggregate base.

~~—b. Residential Locals and Alleys—2 inches of asphaltic concrete over 6 inches of aggregate base.~~

~~—c. All streets shall have a center crowned section with cross slopes slanting toward the gutter with an exception made for a superelevation on account of stormwater control or driver comfort through a horizontal curve.~~

~~—2. Streets and alleys within, adjacent to, or serving a subdivision or development shall be constructed to the full street width indicated in Section 151.08.004. However, the City Engineer may waive the full width requirement under the following conditions:~~

~~—a. When the half width street right of way of a designated Collector or Arterial street adjacent to a subdivision or development is allowed to be platted, the street need only be constructed to its half width provided there is sufficient pavement width for two way traffic [minimum of 26 feet of pavement] and private property adjacent to a proposed subdivision or development is practical for constructing the remaining half width street upon development.~~

~~—b. Where there are existing streets (with adequate width) adjacent to a subdivision or development, proposed streets shall be improved to the intercepting paving line of the existing streets and shall include such paved transitions as the City Engineer may require to provide a safe and non maintenance intensive connection.~~

~~—c. Where a minimum 26 foot paved access road width is allowed, it shall be designed and constructed so that it can easily be widened to the full width street without reconstructing the original 26 feet. Connections to existing and proposed streets shall be designed and constructed to safely accommodate traffic including any traffic control devices and any drainage that may ultimately flow into the street.~~

~~—d. The construction of a Principal Arterial Street is the responsibility of the City. The developer is responsible for the construction of public streets providing access to property adjacent to Principal Arterials.~~

~~—3. Dead end streets shall not be approved except where necessary for the connection to adjacent un platted lands. Where phased development creates a dead end street serving four or more lots, a temporary paved cul de sac, meeting City standards, will be required. Dead end alleys shall be prohibited.~~

~~—4. Street “elbows” shall be required where street radii do not meet code standards. Design characteristics of “elbows” (radii, street width, etc.) shall match the code requirements for a cul de sac.~~

~~L. Curb Gutter Design and Construction. All streets shall have 6 inch high Portland Cement Concrete curbs and gutters along the pavement edge constructed to standards approved by the City, except in the following situations:~~

~~—1. Four inch high rolled curb and gutter may be installed on local streets in residential areas as long as the street drainage required by the drainage provisions can be contained within the right of way. All curbs shall be placed on compacted MAG~~

aggregate base course per the Public Works Engineering Design Standards and Drawings.

—2.— All street corners shall be constructed with 6-inch high vertical curb and gutter and depressed for American With Disabilities Act (ADA) ramps. ADA ramps shall also be provided at the top of all “T” intersections and around the outside of all “knuckles”.

—3.— Where alleys are intended to convey storm water run off, they shall be designed and constructed to include a 4-foot wide concrete valley gutter along the flow line in accordance with Public Works Engineering Design Standards and Drawings.

—4.— A six-inch thickened edge of asphalt may be used in lieu of curb gutter along the inside edge of a half-width street, around a temporary turn-around, at the end of a dead-end street, and along the edge of a minimum standard access road to a subdivision and along the edge of alleys.

—5.— In all cases not otherwise governed by the provisions of the Manual of Uniform Traffic Control Devices, a minimum clearance of two feet shall be maintained between the back face of curb and any obstruction.

—6.— All concrete used for curb gutter shall be per (MAG) Type “A” 3000-psi.

M.— Sidewalk Design and Construction

—1.— Sidewalks shall be located as specified in Section 151.08.004; provided that lighting standards, utility poles, traffic control devices, fire hydrants, mailboxes and similar obstructions can be located a minimum of 1 foot outside of the sidewalk area. In cases where such items cannot be located outside of the sidewalk area, the sidewalks may be located five feet behind the back of curb. The developer is responsible for providing landscaping between the curb and the sidewalk.

—2.— All streets shall have Portland Cement Concrete sidewalks. Sidewalks shall be a minimum of 4 inches thick and 5 feet wide with a 1/4 inch per foot slope toward the street. All concrete used for sidewalk shall be per MAG Type “A” 3000-psi. All sidewalk shall be placed on compacted MAG aggregate base course per the Public Works Engineering Design Standards and Drawings.

N.— Multi-Use Path Design and Construction. All multi-use paths shall be 10 feet wide and paved. The structural cross-section shall be 2” AC over 4” ABC. Refer to the AASHTO “Guide for the Development of Bicycle Facilities”.

O.— Shoulder Design. Interim cross-sections (4 or less travel lanes) can utilize wider shoulders for emergency pull-off and/or striped bike lanes.

P.— Bus Pull Ins. Bus pull ins shall be located as determined by the City. The pull ins shall meet AASHTO and MAG requirements for Arterial and Collector streets.

Q.— Street Survey Monument Construction. Permanent survey monuments consisting of a brass cap set in concrete shall be installed to designate street center lines to be located at all angle points, points of curvature, and at all street intersections. Survey Monuments shall be constructed per the applicable MAG standard detail. A registered

land surveyor shall check the location of monuments, place a punch mark at the true point and stamp their Arizona Registration Number in the cap.

R.—Striping. All required striping of new and/or existing streets shall be installed by the developer in accordance with a plan approved by the City Engineer. All new striping shall be thermoplastic. Striping shall be installed per ADOT standard details, except that the striping width shall be as directed by the City Engineer. Raised pavement markers shall be installed in conjunction with the striping per ADOT standard details. Where necessary, obliteration shall be accomplished by either grinding, sandblasting, or other approved methods.

S.—The subdivider of any residential zoned property directly abutting any public street right-of-way designated as an arterial street on the City's adopted Traffic Circulation Plan, shall construct as part of the required public improvements a six foot high solid masonry wall completely on private property without any openings for vehicle access between the street right-of-way and the private property, excluding approved access points for pedestrians or multi-use paths.

T.—All public improvements shall be constructed per MAG standard specifications and details, except as modified by the Public Works Engineering Division Design Standards and Drawings.

U.—Signing. All signing shall be per the Manual on Uniform Traffic Control Devices. Signposts shall be constructed per the Public Works Engineering Design Standards and Drawings. Signs from other classifications may be installed contingent on a clearly demonstrated need and availability of space within the right-of-way.

(76 Code, Art. 12-1) (Ord. 743, passed 4-10-86; Am. Ord. 834, passed 3-9-89; Am. Ord. 854, passed 1-25-90; Am. Ord. 875, passed 1-10-91; Am. Ord. 1022, passed 12-12-96; Am. Ord. 1022, passed 12-12-96; Am. Ord. 1043, passed 9-11-97; Am. Ord. 1149, passed 9-26-2002; Am. Ord. 2012-004, passed 6-28-12)

Section 151.08.004 Street Design Standards

A.—General Provisions

—1.—Type: PRINCIPAL ARTERIAL.

—a.—Function. To expedite the movement of traffic to and from major trip generators, to collect from and distribute traffic to minor arterial and collector streets intended to carry high volume, high speed traffic with limited access to abutting property.

—b.—Design Volume. 20,000+ vehicles per day.

—c.—Right of Way. 156 feet. The right-of-way shall be extended as needed to accommodate features such as additional travel lanes, dedicated left or right turn lanes, landscaping, utilities, multi-use paths, drainage, etc., as determined by the City.

~~—d. Constructed Street Pavement Width. 94 feet or as determined by the City Engineer based on twenty year projected traffic volumes.~~

~~—e. Number of Moving Thru Lanes. 4-6.~~

~~—f. Design Speed. 60 m.p.h.~~

~~—g. Level of Service. C during peak hours.~~

~~—h. Access. See Section 151.08.005.B.~~

~~—i. Parking. None.~~

~~—j. Intersection Design. See Section 151.08.003.J.~~

~~—k. Horizontal Curves. The minimum radius shall be 1150 feet with a maximum super elevation rate of eight percent. The combination of radius and superelevation shall be in accordance with AASHTO standards. Curb return radii shall be 50 feet to back of curb.~~

~~—l. Length of Tangent. Between horizontal reverse curves shall be a minimum of 500 feet. Length of tangent between reverse vertical reverse curves shall be a minimum of 100 feet.~~

~~—m. No Vehicular Access Easements. See Section 151.08.009.D.~~

~~—n. Vertical Curves. Vertical curves shall be designed at all grade changes where the difference between adjoining grades is 1/2% or more. The minimum length of the vertical curve shall be 350 feet plus 50 feet for each 1/2% of algebraic difference in grade over 1%. Multiple short grade breaks are not an acceptable alternative to a vertical curve.~~

~~—o. Street Grades~~

~~—Maximum—4%.~~

~~—Minimum—0.75%.~~

~~—p. Bicycle Lanes. Bicycle lanes shall be striped and provided on both sides of the street. Additionally, they shall meet the standards in the Principal Arterial Street Profile.~~

~~—q. Multi Use Paths. Multi-use paths shall be required on both sides of the roadway and meet the standards in Section 151.08.003.N. Sidewalks may be allowed as determined by the City.~~

~~—r. Trees and Landscaping. See Article 151.15., 151.18, 151.19, the City of Sierra Vista official plant list, and the City of Sierra Vista public right-of-way landscape specifications.~~

PRINCIPAL ARTERIAL ROADWAY PROFILE

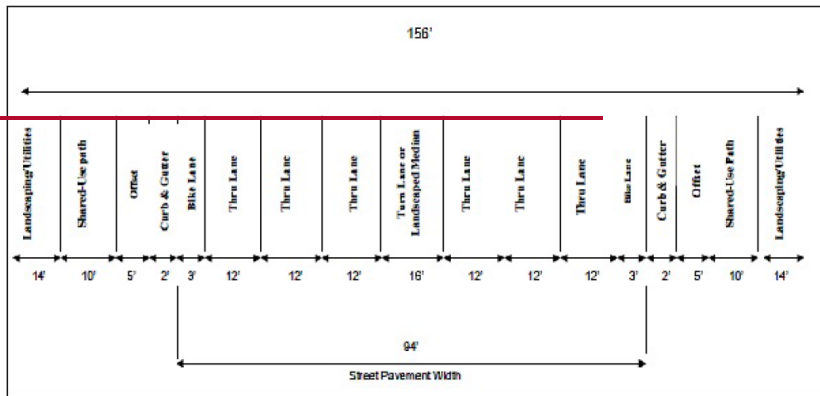

~~2. Type: MINOR ARTERIAL~~

~~a. Function. To collect and distribute traffic from principal arterials to collector streets and to facilitate traffic movement between neighborhoods. The Minor Arterial is intended to carry high volumes of traffic, at moderate speeds, with restricted access to property.~~

~~b. Design Volume. 10,000–20,000 vehicles per day.~~

~~c. Right of Way. 132 feet. The right-of-way shall be extended as needed to accommodate features such as additional dedicated left or right turn lanes, landscaping, utilities, drainage, etc., as determined by the City.~~

~~d. Constructed Street Width. 70 feet.~~

~~e. Number of Moving Thru Lanes. 4.~~

~~f. Design Speed. 50 m.p.h.~~

~~g. Level of Service. C during peak hours.~~

~~h. Access Control. See Section 151.08.005.C for access standards.~~

~~i. Parking. None.~~

~~j. Intersection Design. See Section 151.08.003.J.~~

~~k. Horizontal Curves. The minimum radius shall be 720 feet with a maximum super elevation rate of eight percent. The combination of radius and superelevation shall be in accordance with AASHTO standards.~~

~~l. Length of Tangent. Between horizontal reverse curves shall be a minimum of 300 feet. Length of tangent between reverse vertical reverse curves shall be a minimum of 100 feet.~~

~~m. No Vehicular Access Easements. See Section 151.08.009.D.~~

~~n. Vertical Curves. Vertical curves shall be designed at all grade changes where the difference between adjoining grades is one percent or more. The minimum length of the vertical curve shall be 300 feet plus 50 feet for each one percent of algebraic difference in grade over one percent. Multiple short grade breaks are not an acceptable alternative to a vertical curve.~~

~~o. Street Grades~~

~~Maximum 5%.~~

~~Minimum 0.75%.~~

~~p. Bicycle Lanes. Bicycle lanes shall be striped and provided on both sides of the street. Additionally, they shall meet the standards per the Minor Arterial Street Profile.~~

~~q. Multi Use Paths. Multi-use paths shall be required on both sides of the right of way and meet the standards in Section 151.08.003.N. Sidewalks may be allowed as determined by the City.~~

~~r. Trees and Landscaping. See Article 151.15, 151.18, 151.19, the City of Sierra Vista official plant list, and the City of Sierra Vista public right-of-way landscape specifications.~~

MINOR ARTERIAL ROADWAY PROFILE

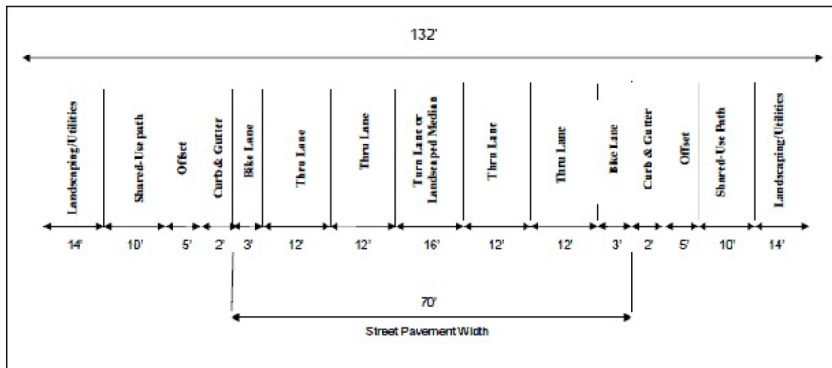

~~3. Type: COLLECTOR STREETS.~~

~~a. Function. Collector streets connect local streets to the high-speed arterial roads or provide access to nonresidential uses and arterial streets. Collector streets form barriers between neighborhoods and are designed for higher speeds and traffic volumes than are local streets. They are intended for utilization by thru traffic with limited direct access from adjacent property.~~

~~b. Design Volume. 5,000-10,000 Vehicles Per Day.~~

~~c. Right of Way. 116 feet. The right of way shall be extended as needed to accommodate features such as additional dedicated left or right turn lanes, landscaping, utilities, drainage, etc., as determined by the City.~~

~~d. Constructed Street Pavement Width. 54 feet.~~

~~e. Number of Moving Thru Lanes. 4.~~

~~f. Design Speed. 40 m.p.h.~~

~~g. Level of Service. C during peak hours.~~

~~h. Access Control. See Section 151.08.005.D for access standards.~~

~~i. Parking. None.~~

~~j. Intersection Design. See Section 151.08.003.J.~~

~~k. Horizontal Curves. The minimum radius shall be 470 feet with a maximum super elevation rate of eight percent. The combination of radius and superelevation shall be in accordance with AASHTO standards.~~

~~l. Length of Tangent. Between horizontal and vertical reverse curves shall be a minimum of 100 feet.~~

~~m. No Vehicular Access Easements. See Section 151.08.009.D.~~

~~n. Vertical Curves. Vertical curves shall be designed at all grade changes where the difference between adjoining grades is one percent or more. The minimum length of the vertical curve shall be 200 feet plus 50 feet for each one percent of algebraic difference in grade over one percent. Multiple short grade breaks are not an acceptable alternative to a vertical curve.~~

~~o. Street Grades~~

~~Maximum - 7%.~~

~~Minimum - 0.75%.~~

~~p. Bicycle Lanes. Bicycle lanes shall be striped and provided on both sides of the street. Additionally, they shall meet the standards per the Collector Street Profile.~~

~~q. Multi Use Paths. Multi-use paths shall be required on both sides of the right of way and meet the standards in Section 151.08.003.N. Sidewalks may be allowed as determined by the City.~~

~~— f. Trees and Landscaping. See Section 151.15, 151.18, 151.19, the City of Sierra Vista official plant list, and the City of Sierra Vista public right-of-way landscape specifications.~~

~~COLLECTOR ROADWAY PROFILE~~

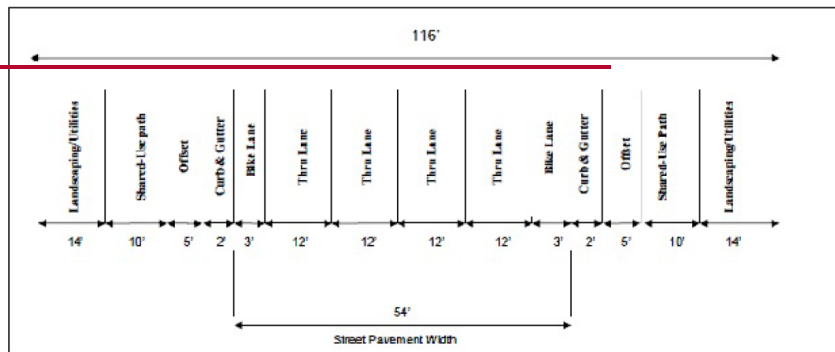

~~— 4. Type: RESIDENTIAL CONNECTOR STREETS.~~

~~— a. Function. Residential Connector streets connect local streets to Collectors and Arterials. They are intended to function as feeder roadways onto which local streets connect. They are intended for through traffic but direct access from adjacent parcels is allowed. The need for a residential collector roadway shall be determined based on the configuration of the subdivision plat as determined by the City.~~

~~— b. Design Volume. Less than 5,000 vehicles per day.~~

~~— c. Right of way. 80 feet.~~

~~— d. Constructed Street Pavement Width. 40 feet.~~

~~— e. Number of Moving Thru Lanes. 2.~~

~~— f. Design Speed. 30 m.p.h.~~

~~— g. Access Control. See Section 151.08.005.B for access standards.~~

~~— h. Parking. Parking is allowed on both sides of the street.~~

~~— i. Intersection Design. See Section 151.08.003.J.~~

~~— j. Horizontal Curves. The minimum radius shall be 260 feet with a maximum super elevation rate of eight percent. The combination of radius and superelevation shall be in accordance with AASHTO standards.~~

~~— k. Length of Tangent. Between horizontal and vertical reverse curves shall be a minimum of 100 feet.~~

~~— l. Vertical Curves. Vertical curves shall be designed at all grade changes where the difference between adjoining grades is one percent or more. The minimum length of the vertical curve shall be 200 feet plus 50 feet for each one percent of algebraic difference in grade over one percent. Multiple short grade breaks are not an acceptable alternative to a vertical curve.~~

~~— m. Street Grades~~

~~— Maximum 7%.~~

~~— Minimum 0.75%.~~

~~— n. Sidewalks. Sidewalks shall be located immediately behind the curb and 5 feet in width. Sidewalk construction standards must meet the criteria stated in Section 151.08.003.M.~~

RESIDENTIAL CONNECTOR ROADWAY PROFILE

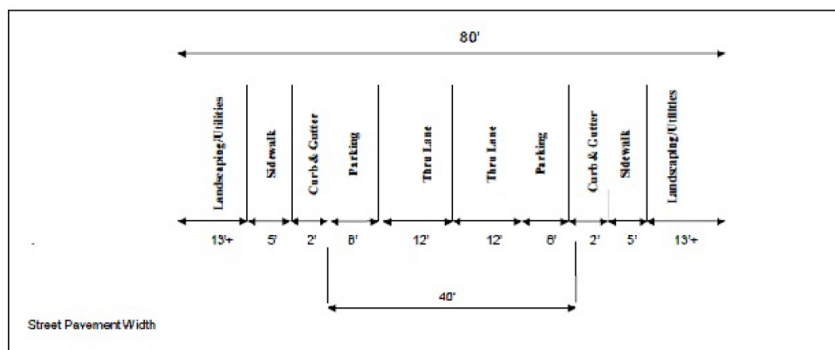

~~— 5. Type: LOCAL STREETS.~~

~~— a. Function. To provide direct access to abutting property and connect to residential connector and collector streets.~~

~~— b. Design Volume. Less than 5,000 vehicles per day.~~

~~— c. Right of Way.~~

~~— (1) Residential Local Street—Varies between 52 feet and 56 feet depending on the Zoning District.~~

~~— (2) Commercial Local Street—66 feet.~~

~~— d. Constructed Street Width.~~

~~— (1) Residential Local Street—constructed street width shall be determined per the matrix.~~

~~— (2) Commercial Local Street — 36 feet.~~

ZONING	CURRENT FRONTYARD SETBACK	STREET WIDTH
SFR-36	40	30
SFR-18	35	30
SFR-12	25	32
SFR-10	25	32
SFR-8	25	32
SFR-6	20	34
MFR	20	34

~~— e. Number of Moving Thru Lanes. 2.~~

~~— f. Design Speed. 25 m.p.h.~~

~~— g. Access Control. Direct access permitted. standards. See Section 151.08.005.F for further access standards.~~

~~— h. Parking. Allowed on both sides of the street.~~

~~— i. Intersection Design. See Section 151.08.003.J.~~

~~— j. Horizontal Curves. The minimum radius shall be 260 feet with a maximum superelevation rate of eight percent. The combination of radius and superelevation shall be in accordance with AASHTO standards.~~

~~— k. Length of Tangent. Between horizontal and vertical reverse curves shall be a minimum of 100 feet.~~

~~— l. Vertical Curves. Vertical curves shall be designed at all grade changes where the difference between adjoining grades is 1% percent or more. The minimum length of the vertical curve shall be 100 feet plus 50 feet for each 1% percent of algebraic difference in grade over one percent. Multiple short grade breaks are not an acceptable alternative to a vertical curve.~~

~~— m. Street Grades~~

~~— Maximum — 10%.~~

~~— Minimum — 0.75%.~~

~~— n. Sidewalks. Sidewalks shall be located immediately behind the curb and 5 feet in width. Sidewalk construction standards must meet the criteria stated in Section 151.08.003.M.~~

LOCAL RESIDENTIAL ROADWAY PROFILE

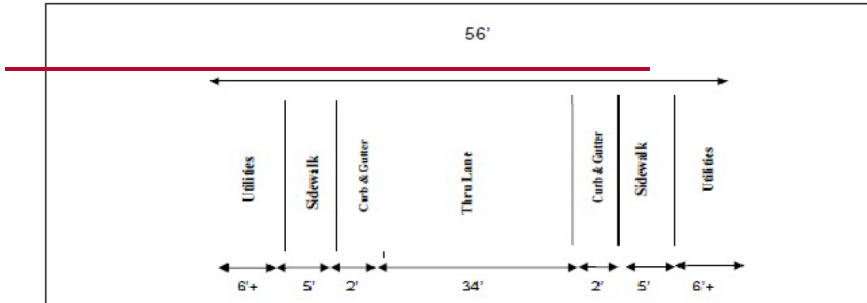

-

NOTE*

The roadway width will vary from 30 feet to 34 feet based on the zoning district. See chart below.

	CURRENT FRONTYARD SETBACK	STREET WIDTH
SFR-36	40	30
SFR-18	35	30
SFR-12	25	32
SFR-10	25	32
SFR-8	25	32
SFR-6	20	34
MFR	20	34

-

LOCAL COMMERCIAL ROADWAY PROFILE

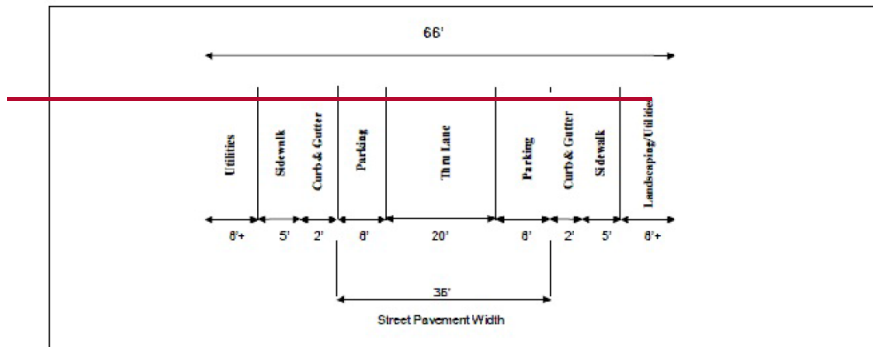

~~6. Type: CUL-DE-SAC.~~

~~a. Function. No cul-de-sac will be longer than 650 feet in length when measured from the center of the bulb or the turnaround to the center of the local, collector or arterial street which provides two directions of access. Another cul-de-sac does not provide two directions of access.~~

~~b. Right of Way. 110 foot diameter circle.~~

~~c. Constructed Street Width~~

~~(1) Residential. 86 foot bulb pavement diameter. 34 foot pavement width in tangent sections.~~

~~(2) Commercial and Industrial. 106 foot bulb pavement diameter. 40 foot pavement width in tangent sections.~~

~~d. Number of Moving Lanes. 2.~~

~~e. Design Speed. 25 m.p.h.~~

~~f. Access Control. See Section 151.08.005 for further access standards.~~

~~g. Parking. Allowed on both sides of the street.~~

~~h. Intersection Design. See Section 151.08.003.J.~~

~~i. Horizontal Curves. The minimum radius shall be 260 feet with a maximum superelevation rate of eight percent. The combination of radius and superelevation shall be in accordance with AASHTO standards.~~

~~j. Length of Tangent. Between horizontal and vertical reverse curves shall be a minimum of 100 feet.~~

~~k. Vertical Curves. Vertical curves shall be designed at all grade changes where the difference between adjoining grades is 1% or more. The minimum length of the~~

vertical curve shall be 100 feet plus 50 feet for each 1% of algebraic difference in grade over 1%. Multiple short grade breaks are not an acceptable alternative to a vertical curve.

~~— l. Street Grades~~

~~— Maximum — 7%.~~

~~— Minimum — 0.75%.~~

~~— m. Sidewalks. Sidewalks shall be located immediately behind the curb and 5 feet in width. Sidewalk construction standards must meet the criteria stated in Section 151.08.003.M. Wherever possible, sidewalk connections shall be made from the bulb of the cul de sac to the next nearest adjoining local street.~~

~~— 7. Type: ALLEY.~~

~~— a. Function. Provide secondary access to multi-family, commercial and industrial properties that also front a public street. Alleys may be required at the rear of multi-family, commercial and industrial developments. Alleys shall be discouraged.~~

~~— b. Right of Way. 20 foot.~~

~~— c. Constructed Alley Width. 20 foot.~~

~~— d. Number of Moving Lanes. 2.~~

~~— e. Access Control. See Section 151.08.005.J for further access standards.~~

~~— f. Parking. None.~~

~~— g. Intersection Design. None.~~

~~— h. Horizontal Curves. 260 foot minimum radius without the approval of the City Engineer.~~

~~— i. Length of Tangent. Between horizontal and vertical reverse curves shall be a minimum of 100 feet.~~

~~— j. Vertical Curves. Vertical curves shall be designed at all grade changes where the difference between adjoining grades is one percent or more. The minimum length of the vertical curve shall be 100 feet plus 50 feet for each 1% algebraic difference in grade over 1%. Vertical curves in lengths of less than the minimum stated may be acceptable, providing standard design features addressing public safety and drainage are not impaired, with the approval of the City Engineer.~~

~~— k. Alley Grades~~

~~— Maximum — 6%.~~

~~— Minimum — 0.75%.~~

~~B. Private Streets~~

~~General Design Standards and Provisions of Private Streets and Alleys. (All collectors or arterials must be public streets).~~

- ~~—1. Private streets and alleys shall meet the minimum pavement cross-section and construction standards as stated in Section 151.08.003.K and 151.08.008.E.4.g and shall be reviewed and inspected by the City to ensure these standards are met.~~
- ~~—2. Private streets shall have a minimum constructed street width of 26 feet.~~
- ~~—3. All private local streets shall be designed to prohibit their use by through public traffic.~~
- ~~—4. Private streets shall be permitted only where a satisfactory means of providing for their control and maintenance is demonstrated. Generally, such control and maintenance shall be accomplished through undivided ownership of private streets by a Property Owner's Association to which all unit owners must belong, under the covenants, conditions and restrictions, Property Owners' Association article and by-laws.~~
- ~~—5. The City of Sierra Vista shall not be responsible for maintenance, liability or enforcement of traffic control on private streets. Erection and maintenance of all traffic control and are the responsibility of the Property Owners' Association. All signs shall be provided by the developer, subdivider, and/or neighborhood association.~~
- ~~—6. Installation and maintenance of street name signs are the responsibility of the property owners association. Such signs shall meet all applicable MUTCD and City requirements.~~
- ~~—7. A sign shall be placed at the entrance of each private street giving notice that the street is a private street.~~
- ~~—8. Private streets shall be named according to current City of Sierra Vista criteria.~~
- ~~—9. If the owners in the future should request that the private streets be changed to public streets, the owners shall fully agree that, before acceptance of such streets by the City, the owners will bear full expense of reconstruction or any other action necessary to make the streets fully conform to the requirements applicable at that time for public streets, and be in new or recently maintained to new condition as accepted by the City Engineer, prior to dedication and acceptance. Finally, the owners shall agree that the right of way shall be dedicated to public use without compensation to the owners for the street improvements and owners' expense in making such streets conform to the requirements applicable at that time for public streets.~~

~~(76 Code, Art. 12-1) (Ord. 743, passed 4-10-86; Am. Ord. 834, passed 3-9-89; Am. Ord. 875, passed 1-10-91; Am. Ord. 925, passed 8-12-93; Am. Ord. 982, passed 5-25-95; Am. Ord. 1056, passed 1-8-98; Am. Ord. 1073, passed 9-10-98; Am. Ord. 1091, passed 5-13-99; Am. Ord. 2012-004, passed 6-28-12)~~

Section 151.08.005 Street Access Standards

~~A.—General Requirements for Street Access~~

~~—1.—Commercial and industrial sites shall generally be limited to one unrestricted access per site.~~

~~—Multi family developments and sites shall be allowed one access for the first 50 units. Two accesses shall be required for sites that have over 50 units. The number of accesses for residential subdivisions shall be based upon the chart in Section 451.08.005.M.1.~~

~~—Considerations such as type of use, size of site, location, safety, and other site considerations shall be used to evaluate access location(s).~~

~~—2.—When a commercial or industrial site fronts two or more streets, generally access shall be taken from the street that has the lower functional classification. Should the streets have the same functional classification, then the street with the least amount of traffic in a 24 hour period, per the latest Public Works traffic counts, shall be used for access. Factors such as lot configuration shall be taken into consideration to evaluate access location(s).~~

~~—3.—The distance between an access and an intersection shall be measured from the edge of the intersection right-of-way to the center line of the access. The separation between intersections shall be measured from centerline to centerline.~~

~~—4.—The stated access requirements are in addition to any emergency vehicular accesses such as a breakaway gate or other such devices that are mandated by the Fire Department and Police Department.~~

~~B.—Principal Arterial Streets. The purpose is to expedite the movement of traffic to and from major trip generators, to collect from and distribute traffic to minor arterial and collector streets, and intended to carry high volume, high speed traffic with limited access to abutting property. No street shall intersect a principal arterial except another arterial or a collector. An internal circulation system must be developed to provide access from abutting properties to a Minor Arterial or Collector as designated on the Traffic Circulation Plan, and thence to the Principal Arterial. Access criteria for Principal Arterial streets shall conform to the following criteria:~~

~~—1.—Principal Arterials—Residential~~

~~—Vehicular access onto any Arterial street from residential property shall be prohibited. In addition, there shall be a dedication of a 1 foot no vehicular access easement along the right-of-way line, and construction of a 6 foot masonry wall as required by Section 451.08.003.S. There shall be no vehicular access gates in such wall.~~

~~—2.—Principal Arterial—Commercial~~

~~—Where allowed, access to commercial properties shall be restricted to right turning movements by way of a raised median along the centerline of the street. Shared driveways are highly encouraged and will be required where the separation between adjacent driveways would be less than 200 feet. Right turn deceleration lanes are~~

required for new development and will be considered for modified site plan development shall be constructed per the Public Works Engineering Design Standards and Drawings.

~~C.—Minor Arterial Streets. The purpose is to collect and distribute traffic from principal arterials to collector streets and to facilitate traffic movement between neighborhoods. The Minor Arterial is intended to carry high volumes of traffic, at moderate speeds, with restricted access to abutting property. Minor Arterial streets shall conform to the following criteria:~~

~~—1.—Minor Arterials Residential~~

~~—Vehicular access onto any Arterial street from residential property shall be prohibited. In addition, there shall be a dedication of a 1-foot no-vehicular access easement along the right-of-way line, and construction of a 6-foot masonry wall as required by Section 151.08.003.S. There shall be no vehicular access gates in such wall.~~

~~—2.—Minor Arterials Commercial~~

~~—Access directly to a Minor Arterial from any commercial or industrial property shall be limited as much as practical. Access shall not be allowed within 300 feet of another access point unless existing development conditions such as existing driveway locations on adjacent properties or property boundary limits make it difficult to comply with the driveway separation requirements. No unrestricted access shall be allowed within 500 feet of a street intersection. Restricted access, where allowed, shall be a minimum of 300 feet from an intersection or as determined by the City. In general, restricted access shall consist of construction of a center raised median meeting City requirements. Right turn deceleration lanes are required for new development and will be considered for modified site plan development and shall be constructed per the Public Works Engineering Design Standards and Drawings.~~

~~D.—Collector Streets—General. Collector streets are designed for through traffic and limited direct access from adjacent property. Access criteria for Collector streets shall conform to the following criteria:~~

~~—1.—Collectors Residential~~

~~—Vehicular access onto any Collector street from residential property shall be prohibited. In addition, there shall be a dedication of a 1-foot no-vehicular access easement along the right-of-way line, and construction of a 6-foot masonry wall as required by Section 151.08.003.S. There shall be no vehicular access gates in such wall.~~

~~—2.—Collectors Commercial~~

~~—Access from commercial and industrial uses shall be limited as much as practical. No unrestricted access shall be allowed within 250 feet of a street intersection. The distance between other access points shall be at least 200 feet unless existing development conditions, such as existing driveway locations on adjacent properties or property boundary limits, make it difficult to comply with access separation requirements. Restricted access, where allowed, shall be a minimum of 200 feet from~~

~~the intersection or as determined by the City. In general, restricted access shall consist of construction of a center raised median meeting City requirements.~~

~~E.—Residential Connector Streets. Residential connector streets connect local streets to Collectors and Arterials. They are intended to function as feeder roadways onto which local streets connect. They are intended for through traffic but direct access from adjacent parcels is allowed. Residential connectors, if needed, shall be identified during the presubmittal phase of the plat.~~

~~F.—Access to Local Streets—General. Local streets are designed to discourage through traffic and to provide access to adjacent property. Accesses on Local streets in commercial and industrial areas shall have a minimum separation of 25 feet from an existing driveway. Access shall be as far as feasible from a street intersection. All uses may take direct access to local streets. Exceptions to these requirements shall be as determined by the City.~~

~~G.—Joint Access. When a developer or property owner develops or redevelops property in such a manner whereby individual parcels are created and are unable to meet the access requirements above, the developer or property owner shall prepare an overall access plan for the entire property. Subject to review and approval by the City, the developer shall be required to establish and record joint access agreements between individual parcels.~~

~~The City may require shared access in circumstances where proximity to intersections makes individualized accesses non-compliant with Code requirements.~~

~~Where parking facilities and driveway access is shared by adjoining developments, an ingress/egress easement shall be recorded authorizing and declaring the purpose and limits of the property to be used.~~

~~H.—Existing Access Points. As of the date of the adoption of this section of the Code, existing access points onto Arterials and Collectors may be allowed to remain. If additional new development occurs on properties with existing access points, certain of those access points may be required to be closed, as determined by the City. The City may restrict existing driveways to certain turning movements by requiring the developer to construct raised medians on Arterials and Collector streets where development may affect the level of service, safety and through function of these major streets.~~

~~I.—Access to Parking from a Street. Access to a parking lot from a street shall be limited to driveways, and there shall be no direct access to any off-street parking space located in a parking lot from a public street.~~

~~J.—Access to Parking from an Alley. Any parking lot may use an abutting alley for direct access to parking spaces; provided that the full width of the alley is dedicated to the public. The portion of the alley between the site access and the street shall be improved per the requirements in the Public Works Engineering Design Standards and Drawings. The location of the site access shall be determined by the City.~~

~~K.— Access Across Land not Owned by Developer. Where primary public access must be provided across land not owned by the developer, the developer shall obtain easements and construct sufficient paving improvements to accommodate two-way traffic (minimum 26-foot wide pavement). Exceptions may be made for private residential streets developed and constructed under the provisions of Section 151.08.003.B.~~

~~L.— Access to Single-Family Residential Subdivisions.~~

~~—1.— The access requirements for a residential subdivision should be as noted on the chart below:~~

-

LOTS	ACCESS
1-100	2 access
101-200	3 accesses
201-300	4 accesses
301-more	Determined by City

-

~~—2.— Subdivisions shall have one access that connects to a Collector roadway. Subdivisions with more than 500 lots shall have at least two accesses that connect to a Collector roadway.~~

~~—3.— At least two accesses shall be separated by a minimum of 1,000 feet when feasible.~~

~~—4.— The stated access requirements are in addition to any emergency vehicular accesses such as a breakaway gate or other such devices that are mandated by the Fire Department.~~

~~—5.— Where access must be provided across land not owned by the subdivider, the subdivider shall at a minimum, provide at least 50 feet of right-of-way and construct a street of sufficient width to accommodate two-way traffic (26-foot minimum).~~

~~—6.— The above requirements may be reduced if configuration of the subdivision or existing conditions makes these requirements impractical.~~

~~M.— Access to Lot. In general, each lot or parcel shall be adjacent to a public street or private streets meeting the requirements of 151.08.004.B. In the case of a development or subdivision, intended for a grouping of commercial uses, mobile homes, apartments, condominiums, or similar compatible uses, the access requirements to interior lots or parcels may be satisfied by paved private access easements granted for the use of the property owners and public service vehicles.~~

~~N.— Pedestrian Access Standards.~~

~~—1. Subdivision Connection.~~

~~—a. All residential subdivisions shall incorporate pedestrian connections designed to connect the proposed subdivision with adjoining existing, or future, residential subdivisions, multi-use paths and/or existing future parks. Such connections are not required to exceed 50 feet beyond the property lines of the development.~~

~~—b. Connection points shall be as determined during the preliminary platting stage of the development and shall be clearly identified on the final plat.~~

~~—c. Where residential subdivisions are located adjacent to a multi-use path, connection to said path shall occur, on average, every 1,000 feet or as determined by the City.~~

~~—d. Pedestrian routes shall be paved and, where located in drainage outlet areas, a minimum of 4 feet in width shall be dedicated to a flat side-to-side surface separate from the drainage portion.~~

~~—e. At least one of the proposed pedestrian connections shall meet Americans with Disabilities Act (ADA) requirements for slope and surfacing. Exceptions shall be as determined by the City.~~

~~(‘76 Code, Art. 12-1) (Ord. 743, passed 4-10-86; Am. Ord. 2012-004, passed 6-28-12)~~

Section 151.08.0036 Water Facilities

A. Standard Engineering Specification

1. Fire Hydrant Design and Construction

a. Fire hydrants shall be installed as required by ADEQ or the International Fire Code (IFC), whichever is more restrictive, and water service shall be provided to each lot. The developer shall be responsible for coordinating fire hydrants and water service design and installation with the water company certified by the Arizona Corporation Commission to service the subdivision. If the City is requested to provide ADEQ approval for water, the developer shall submit an application and provide approved water design plans from the water company along with a signed City of Sierra Vista checklist.

b. For purposes of this section, a fire hydrant is defined as a mechanical device specifically manufactured for the purpose of supplying water from a water main to fire pumping apparatus.

Within the corporate limits of the City of Sierra Vista, fire protection facilities, including fire hydrants and water mains, shall conform to the following minimum specifications and installation criteria.

(1) Fire hydrants shall be spaced at distances no greater than 500 feet for residential developments and 400 feet for commercial and industrial developments. In

cases where it is not feasible to construct hydrants to meet the spacing requirements stated above (as determined by the Fire Chief or his authorized representative) at least one hydrant shall be installed no greater than 500 feet from the furthest point of any proposed new building. For buildings equipped with an automatic sprinkler system in accordance with the IFC, the spacing between fire hydrants can be increased to 600 feet, provided safety concerns are not compromised. The Fire Chief or his authorized designee shall review site conditions and approve the increase in hydrant spacing. All distances shall be measured along the centerline of streets, public ways, or access roadways. Where the most recently adopted IFC or ADEQ requirements conflict with this section the most restrictive shall apply.

(2) Fire hydrants shall have two 2 1/2" outlets and one 4 1/2" outlet. The 4 1/2" outlet shall be installed so that the outlet faces the street and the bottom of the outlet shall be no less than 18-inches above the surface of existing or proposed streets or sidewalks. Threads of all outlets shall be National Standard Hose Threads.

(3) In all zoning districts, water mains supplying water to fire hydrants shall be no less than six inches in diameter. Water mains shall be looped and valving installed such that a single break in the water distribution system shall not necessitate shutting from service a length of pipe no greater than 500 feet. In cases where it is not feasible to loop the water system (as determined by the Fire Chief or his authorized representative) water mains supplying water to fire hydrants shall be no less than eight inches in diameter.

c. If the existing water system is incapable of supplying adequate fire flow, then there shall be provided such additional water supply as may be necessary to provide the flow required for fire protection. Water supply may consist of wells, reservoirs, pressure tanks, elevated tanks, water mains, or other fixed system capable of supplying the adequate fire flow or other measures as determined by the IFC. In determining the required fire flow for fire protection, the standards published by the IFC, shall be used as a guide.

d. Fire hydrant caps shall be painted chrome yellow and color coated to represent the gallons per minute flow as per National Fire Protection Association (NFPA) 24.

e. Installation of fire hydrants shall follow the requirements of the IFC, the NFPA, and the City of Sierra Vista Development Codes.

2. Water Line Design and Construction. See Section 151.08.002.D.

('76 Code, Art. 12-1) (Ord. 743, passed 4-10-86; Am. Ord. 764, passed 1-8-87; Am. Ord. 1022, passed 12-12-96; Am. Ord. 1043, passed 9-11-97; Am. Ord. 1056, passed 1-8-98; Am. Ord. 2012-004, passed 6-28-12)

Section 151.08.004 Sewerage Facilities

A. General Provisions

1. Purpose

The purpose of this section is to provide for the orderly development of an area-wide Water Reclamation System which will collect, treat, and reuse the public's sewerage in a manner that will protect the public health, safety and welfare, be compatible with the environment, and minimize the economic impact on the users of the Water Reclamation System. Its purpose is also to manage and control the use of the Water Reclamation System in accordance with all Federal, State, and local laws, rules, and regulations.

2. Administration and Enforcement

The administration and enforcement of this section shall be the responsibility of the City Engineer, unless otherwise specifically assigned herein or elsewhere in the City Code or Development Code. The City Clerk is responsible for the collection and the Finance Manager is responsible for the accounting of all revenues, reserves, and expenditures as provided by this section.

3. Application

Unless otherwise specifically provided herein, the provisions of this section shall apply to any development within the area assigned by the Arizona Department of Environmental Quality (ADEQ) or other appropriate authority of the State of Arizona to the City of Sierra Vista, as Wastewater Manager, and to any sewer user connected to the wastewater system owned and operated by the City of Sierra Vista. The provisions of this section are not intended to conflict, nor shall they supersede, any Federal or State law to the contrary. Any provisions herein which may conflict with Federal or State Law shall be resolved in favor of the controlling or applicable Federal or State provision.

4. Fees

The fees and charges provided in this section are in addition to any fees, charges, or assessments required by Section 151.08.007.F, any plumbing permit fees, any building permit fees, or to any other fees, charges, assessments or taxes that may be legally due and owing to the City.

B. Definitions

1. Sewage is any liquid lawfully discharged into the City's sewer system and becomes the property of the City upon entrance to any sewage collection pipe owned by the City.

2. Sewer System/Water Reclamation System is used interchangeably to describe all the sewage collection, treatment, and disposal facilities owned by the City.

C. Ownership of Sewerage Facilities

1. Public Ownership

The City shall own and have exclusive control of all sewer facilities installed pursuant to this Code upon completion of construction in conformity with plans and specifications approved by the City and upon acceptance by the City of the sewerage facilities for

maintenance, except as provided in paragraph 2., "Private Ownership," below. The City Sewer Enterprise will operate and maintain all sewerage facilities owned by the City that are located within a public right-of-way or easement.

2. Private Ownership

Sewage and plumbing facilities intended for the private use of an individual owner upstream from the point of connection to the public sewer system, as determined by the City, shall be owned, operated, and maintained by the property owner in accordance with all applicable laws, rules and regulations. Such private sewage and plumbing facilities shall include: House service connection lines, building sewers, pre-treatment facilities, septic tanks, leach fields, plumbing and fixtures inside a building and other similar facilities located upstream from the point of connection to the public sewer system. For private ownership to occur for facilities larger than 4-inch house connect services, it shall be demonstrated that the responsible party has capabilities or can obtain the means to properly service the system for scheduled and emergency repair and maintenance.

3. Right-of-Way Required

Any person constructing or causing the construction of any sewerage facilities to be owned by the City, shall obtain and dedicate to the public any right-of-way or public easements determined by the City to be necessary for the construction, operation, and maintenance of such sewer facilities. All required dedications shall be made prior to the connection of any sewer facilities to the City Water Reclamation System. A minimum 20-foot sewer easement shall be provided to the City. Easements for sewer facilities shall not be part of any private lot where a manhole is required within the lot. Sewer facilities in easements across private property shall be avoided.

4. Ownership Condition of Service

Provision of right-of-way or easements and City ownership of sewer facilities as required above is a condition for connecting to, or using, the City Water Reclamation System, to the provision of sewer service and to approving any reimbursement agreement. Connection to, or causing the connection to, the City Water Reclamation System shall be considered a transfer of ownership as required above, and an acceptance by the property owners and any subsequent user of the system of the obligations and requirements of this section of the Code.

D. Sewer Facilities Required

1. Connection to Public System Required

The owner of any property where sewage is generated shall be connected to a public sewer system approved by ADEQ, unless specifically allowed by this section to be connected to a private sewer system (septic tank) approved by the County. Connection to a public sewer system shall be made at the nearest usable sewer as determined by the City Engineer and at the owners' sole expense. The property owner shall pay all assessments and charges due and owing, and shall enter

into a contract provided by the City for service, before connecting to, or using, the City Water Reclamation System.

The "nearest usable City sewer," as used in this section, shall mean a sewer which has sufficient capacity, for the sewer's full length to an adequate treatment facility, to accept the sewerage projected by the most current City Sewer Master Plan to be generated from the sewer's service area under full build out (saturation) conditions.

2. Temporary Connection to Private System Allowed

Property may be allowed by the City Engineer to connect to a private sewer system (septic tank) approved by the County where the following situations exist:

a. Property where all buildings were constructed and allowed to connect to a private sewer system by the City or County under the authority of previously adopted laws, rules, or regulations, unless a change in use has occurred which results in a total average daily sewerage flow greater than 200 gallons per day, or the sewerage is characterized as having a strength greater than "domestic" sewage as determined by the City, or unless the health official appointed by the County has determined that the existing private sewerage system is, or has the potential to create, a health hazard.

b. Property outside the City which has been exempted from the requirement to connect to a public sewer system by the health official appointed by the County.

c. The service connection fee is more than \$6,000 for a dwelling or \$10 times the daily design flow in gallons for a source other than a dwelling and the cost of constructing the sewer from the wastewater source to the service connection is more than \$3,000 for a dwelling or \$5 times the daily design flow in gallons for a source other than a dwelling.

E. Design and Construction of Sewerage Facilities

1. Design Documents

All sewerage facilities to be connected to, and to become a part of, the City Water reclamation System shall be designed and constructed in conformance with the following documents as they may exist in the Section 208 area plan, or may be amended in the future.

a. The Waste Water Management and Sewerage Master Plan adopted by the City Council.

b. Engineering Bulletin 11 and all other applicable laws, rules, and regulations of the Arizona Department of Environmental Quality.

c. Uniform Standard Specification for Public Works Construction and the Uniform Standard Details for Public Works Construction as compiled by the Maricopa Association of Governments.

d. City of Sierra Vista, Public Works Engineering Design Standards and Drawings as compiled by the City Engineer.

2. Document Conflict

In case of conflict between the referenced documents, the City Engineer shall determine the applicable design or construction requirement. In general, the more stringent or conservative requirement will be applied.

3. Engineer Required

Any person desiring to construct public sewerage facilities and connect to the City Water Reclamation System must employ a Professional Engineer registered by the State of Arizona to perform sewer design and construction services. The Professional Engineer must prepare plans and specifications for the construction of the sewerage facilities and submit them through the Director of Community

Development for approval by the City Engineer. Construction of sewerage facilities cannot begin until the plans and specifications have been approved by the City Engineer and Arizona Department of Environmental Quality and a Sewer Extension Agreement provided by the City has been executed by the property owner constructing the sewerage facilities and the City.

The Professional Engineer must perform construction engineering services to assure the sewer facilities are constructed in accordance with the approved plans and specifications. Construction engineering services include field surveillance of the contractors activity and inspection and testing of construction procedures and materials. All construction engineering services are subject to review and approval by the City Engineer. The Professional Engineer shall submit to the City Engineer copies of all materials testing reports and weekly inspection reports during the progress of the work.

Upon completion of the work, the Professional Engineer shall submit to the City Engineer "as- built" plans depicting the sewer facilities as they were constructed, and a certification that the sewer facilities have been constructed in substantial conformity with the plans and specifications. Upon receipt of such plans and certifications and a determination that the sewer facilities have been properly constructed, the City Engineer shall notify the Department of Public Works that the sewer facilities can be accepted for maintenance. Upon completion of the work, the contractor performing the work, and the person causing the work to be done, shall submit to the Director of Community Development satisfactory assurance that the sewer facilities are free of any liens or encumbrances and are guaranteed against any defects in materials or workmanship for a period of two years. All submittals must be made and approved by the Director of Community Development and all required right-of-way or easements must be provided to the Director of Community Development before the sewer facilities can be accepted for maintenance by the City or used by any property owner.

4. Special Provisions

a. A separate, private sewer connection to a public sewer shall be provided for each building and for each separate ownership within a building. Ownership of a building by a condominium association will be considered a single ownership for the purposes of this provision. In a commercial or mixed-use development, combined

private connection may occur if an approved maintenance agreement is put into effect where all possible parties are obligated to participate and funding of maintenance improvements is included.

b. No private sewer connection will be permitted to a public sewer larger than 10 inches in diameter without a manhole, unless approved by the City Engineer.

c. All private sewer connections shall be constructed with a clean-out and a serviceable back flow prevention valve per the Sierra Vista Engineering Design and Construction Standards.

d. In conformance with ARS 40-360.22 all lateral sewer lines, in the City right-of-way, shall be identified by installing a 14 AWG copper wire with green type UF insulation, the full length of the lateral, secured every 10-feet, and terminated at a clean-out riser and meter box at finish grade.

e. Sewer backflow devices shall be located where they will be accessible for inspection and repair at all times and, unless continuously exposed, shall be enclosed in a below ground pit fitted with an adequately sized removable cover.

The backflow device shall be located at the connection of the building drain and the house connect service sewer line. A clean-out shall be located on each side of, directed away from, the backflow device.

f. On residential installations, the backflow device pit may be omitted provided the top of the backflow device is not deeper than four feet below grade, the ground above the device can be readily excavated, and a clean-out cover identifies the device location.

g. No private sewer connection lines will be constructed parallel to any public right-of-way or easement lines, or otherwise be designed in an effort to avoid a property owner's obligation to construct the minimum sewer facility to serve the owner's property.

h. Any user connected to the City wastewater system that discharges grease or any other substance that causes or is likely to cause sewer stoppages, as determined by the City, shall install and properly maintain a grease interceptor or other approved pre-treatment method to prevent such occurrences in accordance with Chapter 50 of the City Code of Ordinances and the Public Works Engineering Standards.

i. Where preliminary treatment or flow-equalizing facilities are provided for any waters or wastes, they shall be maintained continuously in satisfactory and effective operation by the owner at his/her expense.

j. When required by the Director of Public Works, the owner of any property serviced by a building sewer carrying industrial wastes shall install a suitable control manhole together with such necessary meters and other appurtenances in the building sewer to facilitate observation, sampling, and measurement of the wastes. Such manhole, when required, shall be accessibly and safely located, and shall be constructed in accordance with plans approved by the Director of Community

Development. The manhole shall be installed by the owner at his/her expense and shall be maintained by him/her so as to be safe and accessible at all times.

F. Financing Sewer Facilities - General

1. Financial Responsibilities

The City Water Reclamation System is a user-financed, publicly owned and operated municipal utility system called a Sewer Enterprise. A user of the Water Reclamation System is the owner of any property where sewage is generated, and who is required to connect to the City Water Reclamation System in accordance with the provisions of Chapter 50, Sewers, of the City's Code of Ordinances. Each user is responsible for funding an equitable share of the capital assets of the system, of the operating and maintenance costs of the system, and of any other costs or liabilities of the system that may be incurred in the process of collecting, transporting, treating and reusing sewage in accordance with this code.

a. Sewer Facilities to extend the collection and transportation system are financed and constructed solely by a property owner and are considered to only benefit the property owner constructing the sewer facility. No costs for constructing Sewer Facilities are recovered because they are considered part of the property owners' equitable share contribution to the capital assets of the Sewer Enterprise.

b. Replacement & Augmentation Sewer Facilities intended to replace worn out or poorly designed or constructed portions of the existing collection and transportation system are financed and constructed by the Sewer Enterprise and are considered to indirectly benefit all users of the City Water Reclamation System. All costs for constructing Replacement Sewer Facilities are accumulated and/or recovered from all property owners/users as monthly Capital Service Charges. The Sewer Enterprise is required to develop a financial plan and assess charges to fund Replacement Facilities for the collection and transportation system.

('76 Code, Art. 12-1) (Ord. 743, passed 4-10-86; Am. Ord. 854, passed 1-25-90; Am. Ord. 875, 1-10-91; Am. Ord. 956, passed 8-11-94; Am. Ord. 988, passed 9-28-95; Am. Ord. 1043, passed 9-11-97; Am. Ord. 1049, passed 11-13-97; Am. Ord. 2003-021, passed 11-25-03; Am. Ord. 2012-004, passed 6-28-12; Am. Ord. 2018-002, passed 3-22-18)

Section 151.08.0058 Surface Drainage and Storm Sewer Systems

A. General Provisions

1. Purpose

The primary purpose of this section is to outline and define the drainage planning and management practices necessary to mitigate potential flooding and to provide for an orderly, controlled means of collecting, controlling, and allowing drainage runoff to flow safely through the community.

A secondary purpose is to allow a means to replenish groundwater supplies by enhancing absorption of surface water. To accomplish these purposes, the City has adopted the Surface Water Plan for the City of Sierra Vista, prepared by Simons, Li & Associates, Inc.

The requirements stated herein shall be adhered to and are required of all new developments. These requirements will also be used as guidelines for the improvement of existing developments.

2. Administration and Enforcement

The administration and enforcement of this section shall be the responsibility of the City Engineer, unless otherwise specifically assigned herein or described in the Development Code.

3. Interpretation and Application

In the interpretation and application of this section, all provisions shall be considered as minimum requirements and are subject to approval by the City Engineer as they apply to the Development Code requirements.

Unless otherwise specifically provided herein, the provisions of this section shall apply to any subdivision or commercial development or the improvement of any lot or parcel, developed or undeveloped, within the City of Sierra Vista.

Interpretations and the implementation of the drainage concepts described by this section are not intended to violate the regulations of the Federal Emergency Management Agency or the National Flood Insurance Program with regard to floodway encroachments or the requirements of Section 151.22.029.

4. Circumvention Unlawful

It shall be unlawful for any person to change the location or character of any watercourse, change the flow of any surface water; construct any structure that may retard or impede the historical flow of a drainage course; or modify the ground surface permeability in a manner that will result in an increase in the amount of storm water flow without the written permission of the City Engineer as allowed by this section.

It shall be unlawful to direct and discharge storm water into a wastewater sewerage system. A storm water drainage system shall be separate and required whenever the storm water flow exceeds the street drainage carrying capacity, as defined herein.

B. Responsibility for Improvement

It is the responsibility of the developer to finance the planning, design, and construction of all drainage improvements on site or off site, as may be required by the City.

1. Dedication of Right-of-Way

The developer shall be required to dedicate to the public sufficient right-of-way and easements for the maintenance of the public drainage improvements associated with

the development. Adequate right-of-way or an ingress/egress easement, no less than 20 feet wide, shall be provided by the developer to access all public drainage improvements. Dedicated drainageways and access easements must be traversable by a vehicle.

2. Design and Construction

Design and construction of the required public drainage improvements shall be made in accordance with Section 151.08.002.D and the applicable requirements of this section. Inspection and acceptance by the City for maintenance shall comply with the procedures outlined in Section 151.08.002.G.

C. Drainage Reports

A drainage report shall be required for all new development, for new development on existing sites, and subdivisions. The drainage report shall contain all necessary calculations and information necessary to justify all recommendations made by the study, or as directed by the City. All drainage reports shall be prepared and stamped by a professional civil engineer, registered in the state of Arizona and shall address all the requirements of this section and any other requirements deemed necessary by the City Engineer.

1. Preliminary Drainage Reports: Preliminary drainage reports are required to be submitted with preliminary plats. The purpose of the preliminary drainage report is to accurately establish hydrologic conditions associated with both the existing site conditions and the conditions upon completion of the proposed development. Hydrologic calculations presented in the preliminary drainage report should be considered complete. Hydraulic design components associated with the proposed development shall be presented in conceptual terms. Hydraulic calculations associated with collection, conveyance, and detention/retention of stormwater are to be included in the preliminary drainage report to the extent necessary to demonstrate the feasibility of the proposed improvements. If the development is adjacent to a wash, the preliminary report will address the wash hydrology, identify floodplains currently defined by FEMA, show floodplain boundaries (as determined by FEMA or the developer's engineer), identify any existing or proposed erosion setback limits, discuss the wash designation identified in the Surface Water Plan for the City of Sierra Vista, and discuss proposed improvements in the wash at a conceptual level. At a minimum, the preliminary drainage report shall include:

- a. A table in the text portion of the report showing the size of the watershed or subbasin areas.
- b. A table in the text portion of the report showing runoff coefficients or soil parameters.
- c. A table in the text portion of the report showing pre-development peak flows (10-year and 100-year, 1-hour design storms).
- d. A table in the text portion of the report showing post-development peak flows (including effects of storm water basins).

e. A map in the text portion of the report showing the locations where storm water discharges from the site in pre-development conditions and post development conditions.

f. A table in the text portion of the report showing the peak flow and high water elevations expected in all components of collection and conveyance systems, including storm water basins. This information may be omitted from the preliminary drainage report but must be included in the final drainage report.

g. The required tables may be combined as long as the information presented is clear and complete.

2. Final Drainage Reports: Final drainage reports are required to be submitted with final plats and site plans. The purpose of the final drainage report is to document all hydrologic and hydraulic design associated with the development. All information presented in the preliminary drainage report shall be revised and finalized as required and included in the final drainage report. The final drainage report shall present complete hydrologic calculations and complete hydraulic calculations in one bound volume. The final report may not refer to the preliminary report for calculations or other information. The conditions documented in the final drainage report shall match the proposed improvements shown on the final plans.

D. Hydrologic Methods and Design Requirements

Hydrologic methods that may be used when determining on-site and off-site drainage runoff shall be as follows, or as approved by the City Engineer:

1. Rational Method for watersheds that have a calculated time of concentration of less than 30 minutes in the pre-development condition. Rational Method calculations shall be based on the following parameters:

a. Design storms shall be the 10-year, 1-hour storm (precipitation depth 1.63 inches) and the 100-year, 1-hour storm precipitation depth 2.43 inches.

b. Small area watersheds such as those modeled using the Rational Method are assumed to experience high intensity storms (design storms) as a result of summer thunderstorms.

c. Intensity-Duration-Frequency Curves as provided by the City of Sierra Vista.

d. Time of concentration (TC) as determined by either the Highway Drainage Design Manual, ADOT, 1993 or the Drainage Design Manual for Maricopa County Arizona, Volume I, Hydrology, 1995 Revision. Minimum time of concentration to be 10 minutes.

e. Runoff coefficient (C value) for pre-development conditions to be $C=0.35$. This C value shall apply to both the 10-year and 100-year design storm. Landscaped areas on the developed site are to have a C value of 0.35 or greater. Pre-development condition calculations are to assume that the entire site is undeveloped for the purposes of storm water basin design.

f. Post-development C values are to be based on the values in Table 151.08.006-1. Site specific C values may calculated and included in the drainage report along with supporting documentation.

Table 151.08.006-1
Post-Development C Values

Land Use	C Values
Commercial Sites	
Asphalt	0.90 ⁽¹⁾
Concrete	0.90 ⁽¹⁾
Roof	0.95
Landscape Areas	0.35
Residential Subdivisions ⁽²⁾	
4,500 sf lots	0.74
5,000 sf lots	0.71
5,500 sf lots	0.69
6,000 sf lots	0.67
6,500 sf lots	0.66
7,000 sf lots	0.64
7,500 sf lots	0.63
8,000 sf lots	0.62
9,000 sf lots	0.60

Formatted: Centered, Don't add space between paragraphs of the same style

Formatted: Underline

⁽¹⁾ C Values for pervious pavements shall be evaluated on a case by case basis. Pervious pavements shall not be permitted for street construction.

⁽²⁾ C Values for residential subdivisions shall include estimated area occupied by the required storm water basin.

g. Hydrographs are to be used to analyze the performance of proposed storm water basins. Hydrographs for these small watersheds are to be created using the methodology described in the Standards Manual for Drainage Design and Floodplain Management in Tucson, Arizona, 1998 Revision. Hydrograph duration is to be a minimum of 60 minutes (to match the design storm).

h. Hydrographs may be routed through storm water basins using spreadsheets, HEC- HMS/HEC-1 or a commercial software developed for this purpose.

2. HEC-HMS OR HEC-1: analysis for watersheds that have a calculated time of concentration of greater than 30 minutes in the pre-developed conditions. HEC-HMS/HEC-1 calculations shall be based on the following parameters:

a. Design storms shall be the 10-year, 1-hour storm (precipitation depth 1.63 inches) and the 100-year, 1-hour storm precipitation depth 2.43 inches.

b. Large area watersheds such as those modeled using HEC methodology are assumed to experience high intensity storms (design storms) as a result of winter frontal systems.

c. HEC models shall be created using the unit hydrograph procedures outlined by the Highway Drainage Design Manual, ADOT, 1993.

d. Rainfall intensities for watersheds that lie within the City limits shall be determined from Intensity-Duration-Frequency Curves as provided by the City of Sierra Vista. Watersheds located wholly or partially in the Huachuca Mountains shall have site-specific IDF curves prepared as described in the Highway Drainage Design Manual, ADOT, 1993.

e. Storm distribution shall be modeled using the appropriate time-area relation curves shown in the Highway Drainage Design Manual, ADOT, 1993.

f. Soil parameters-soil loss parameters shall be based on the information contained in the Soil Survey of Cochise County, Arizona, Douglas-Tombstone Part, Natural Resources Conservation Service (2000 data). Soil permeability (XKSAT) shall be the lowest value shown for permeability in Table 14 of the Soil Survey. Analysis of data in Table 14 shall take into account the permeability of the first foot of the soil horizon. A composite XKSAT value is to be used for watersheds containing blended soil horizons or watersheds containing multiple soil types. Highly permeable soils in washes shall be excluded from overall watershed runoff calculations.

g. Transmission losses are not to be used in wash routing routines.

3. Washes Designated as FEMA Floodplains - Project specific revisions to the hydrology calculations will not be accepted for washes currently designated as FEMA Floodplains. The peak flows used to determine the current 100-year FEMA floodplains shall be considered accurate for the purpose of development review. Developers wishing to revise FEMA wash hydrology must do so by obtaining a Letter of Map Revision (LOMR) from FEMA.

E. Hydraulic Methods and Design Requirements

Hydraulic calculations shall be included in the drainage report to demonstrate the hydraulic adequacy of all proposed drainage structures. Calculations shall be based on the information contained in Current version of the current version of the (DRAFT) Drainage Design Manual, for Maricopa County, Arizona, Hydraulics, Flood Control District of Maricopa County or Urban Drainage Design Manual, Hydraulic Engineering Circular No. 22, Federal Highway Administration, November 1996. Other published manuals may be used with pre-approval of by the City Engineer. Hydraulic design shall be subject to the following requirements:

1. Drainage Structure Design Criteria. Hydraulic structures shall be designed to collect and convey the calculated peak flow for the 100-year, 1-hour design storm. In no case may the drainage leave the public right-of-way for any new flows up to and including the 100-year storm event.

2. Freeboard. A minimum of 1 foot of free board shall be provided in all conveyance structures except streets. This includes storm drains, ditches, washes, channels, and storm water basins.

3. Grading of Commercial and Residential Lots. Lots shall be graded so that:

a. All lots shall be graded toward the roadway from where the property takes access so that positive drainage to an improved public street right-of-way is assured during and after development. As an alternative, runoff may be discharged to an adjacent, improved drainage easement, a dedicated drainageway, or an alternative street, provided the drainage alternative is approved by the City Engineer.

b. Cross-lot drainage will not be allowed in residential subdivisions.

c. Cross-lot drainage may be allowed for commercial development as long as cross-lot drainage easements are recorded and CC&R's are in place assigning maintenance responsibilities.

d. All finish floor elevations shall be constructed a minimum of one foot above the base flood elevation of any abutting street, drainage easement, drainageway, detention basin, or other storm water conveyance facility.

e. If existing conditions make it difficult to comply with the finish floor elevation requirements, the City may approve the construction of an acceptable drainage control structure, designed by a professional civil engineer, which will afford at least the same margin of safety that had the finish floor been constructed one foot above the base flood elevation. Alternative drainage designs are subject to review and approval of the City Engineer.

f. Certification of finish floor elevations: The developer shall submit final as-built plans in electronic format showing all lot drainage, lot grading, building pad elevations, finish floor elevations (if available) and the highest 100 year base flood adjacent to each lot. Final as-built plans shall show the approved design conditions and reflect any field changes approved by the City and the developer's engineer. The developer's engineer shall certify that the final plans represent as nearly as possible the actual field conditions of all improvements as constructed.

g. As-built drawings may serve as certification for lots whose pad elevations are at least one foot above the 100-year base flood elevation. However, when pad elevations are less than one foot above the 100-year base flood elevation, the proposed finish floor elevation shall be certified to be a minimum of one foot above the 100 year base flood elevation by a registered land surveyor (RLS). The RLS shall use the City's elevation certificate for certification.

h. If the City determines that actual pad elevations are different than the as-built drawings, an elevation certificate shall be required.

4. Streets. Storm runoff conveyance in streets shall be designed so that:

a. Flow depth shall not exceed 0.6 feet at any location during the 100-year storm.

b. Flow volume shall not exceed 60 cubic feet per second (cfs) at any location during the 100-year design storm.

c. Runoff from local streets shall not cross an arterial or collector street. Runoff from local streets may be diverted to the gutters of arterial and collector streets if it does not violate the drainage criteria for the arterial or collector street.

d. Flow depth in major intersections (where both streets are collector or above) is to be limited to 0.6 feet during the 10-year design storm. Valley gutters may be used to convey flow across either street.

e. Storm drains or collection systems shall be provided in locations where estimated flows exceed the allowable flow volume or flow depth. Nuisance flows (very small amounts of water that wouldn't leave the gutter pan) shall always be conveyed on concrete surfaces (curb and gutters or valley gutters). Nuisance flows will not be permitted on any asphalt surfaces.

f. A four-foot wide concrete valley gutter with no more than a 1/2" depression shall be required at all intersections within a subdivision where drainage is required to cross a local street. Valley gutters may be constructed at local streets intersecting arterials or collectors as needed to properly preserve the historical flow direction.

g. A four-foot concrete valley gutter shall be required along the centerline of all new alleys that receive direct runoff discharge from private property. The design and construction of alley improvements shall be in accordance with Section 151.08.003.K of the Sierra Vista City Code, and be capable of conveying the expected 100-year peak discharge entirely within the alley cross-section. The depth of flow at the flow line shall not exceed 0.6 feet.

h. The existing and proposed street drainage capacity shall be evaluated for all streets as impacted by all new developments. Lack of street drainage capacity, as specified above, shall require the construction of storm drains, additional detention improvements, or a combination of the two requirements as a means of controlling street drainage.

i. Collection of storm water in a sump or sag condition will only be permitted if a non-clogging, emergency overflow is provided. Storm flows must be able to leave the sump area in an open channel such as a ditch or a street without endangering a structure. The highest inert elevation of the emergency overflow must be at least 1 foot below the finish floor elevation of structures that might be affected by flow in the emergency channel.

5. Street Drainage Crossings. Storm water may be conveyed across streets using culverts or dip crossings. The following design criteria shall apply:

a. Storm water crossings of arterial streets shall pass the 100-year peak discharge under the roadway.

b. Design of storm water crossings of all collector and local streets shall provide all weather access. A culvert is required that will pass the 100-year discharge under the roadway where the discharge is 500 cubic feet per second (cfs) or more.

c. Where the storm water discharge is less than 500 cfs at a collector and local streets, a portion of the storm water may be allowed to cross over the roadway. If a portion of the flow crosses over the roadway, flow depth in the roadway may not exceed 0.6 feet in depth and the 100-year peak flow must be fully contained within the right-of-way (channel right-of-way and street right-of-way).

d. Drainageways or open channels may cross a local street carrying no more than 1,000 vehicles per day, as determined by the Trip Generation manual of the Institute of Transportation Engineers, if there exists at least one all-weather access route available to all properties in the area to be developed. A concrete pavement crossing is required at all dip crossings. Painted bollards are required at the sides of the concrete pavement to show depth of flow. Advance warning signs shall advise motorists not to cross when flooded. The 100-year discharge must be contained within the drainage/street right-of-way.

e. The bottom is earthen with grade control structures and the banks are armored when the conditions above are exceeded.

f. Bank armor that has a natural appearance when established. Rip rap, gabions, rail bank, and pre-approved geotechnical reinforcing mats are encouraged. Concrete and grouted rip rap are discouraged for use as bank armor.

g. Bed erosion is to be controlled by grade control structures. See requirements for grade control structures below.

6. Ditches and Channels. Shall be designed so that:

a. Anticipated velocities in unarmored ditches and channels shall not exceed 3 feet per second (fps). Peak flow in unarmored ditches and channels shall not exceed 50 cfs.

b. The bottom is earthen with grade control structures and the banks are armored when the conditions above are exceeded.

c. Bank armor that has a natural appearance when established. Rip rap, gabions, rail bank, and pre-approved geotechnical reinforcing mats are encouraged. Concrete and grouted rip rap will not be permitted for use as bank armor.

d. Bed erosion is to be controlled by grade control structures. See requirements for grade control structures below.

7. Grade Control Structures. Grade control structures are to be designed using the following criteria:

a. Channel bottom is to be left as natural earth or armored in such a way as to encourage vegetation growth. Longitudinal concrete or grouted rip rap armor in channel bottoms will not be permitted. Localized armor is required to control erosion at grade control structures.

- b. Equilibrium slope of all channel bottoms is assumed to be zero (level).
- c. Depth of grade control structures shall be at least 1 foot below the calculated scour depth.
- d. Maximum depth of grade control structures to be 6 feet unless the structure is designed structurally support the upstream channel bed. Design of deeper grade control structures require structural calculations stamped by a civil engineer registered in the state of Arizona.

8. Bank Armor. Bank armor is to be designed using the following criteria:

- a. Channel bottom is to be left as natural earth or armored in such a way as to encourage vegetation growth.
- b. Channel armor shall extend at least one foot below anticipated scour depths longitudinally and at grade control structures.
- c. Channel armor shall extend at least one foot below anticipated equilibrium bed of channel. Bed elevations to be determined from downstream hard points such as grade control structures or culvert crossings.
- d. Channel armor shall extend one foot above calculated water surface elevations. Water surface elevation calculations shall include the anticipated superelevation in bends.

9. Storm Drains. All storm drain systems are to be designed using the following criteria:

- a. Design of all storm drain system shall include hydraulic grade line (HGL) calculations. HGL to be at least one foot below all inlets and manholes.
- b. HGL calculations to account for all friction losses including entrance and exit losses, bend losses, and pipe friction losses.
- c. HGL calculations are to assume water surface elevation at outlet at the top of pipe. Alternate outlet water surface elevations may be used if supported by hydraulic calculations.

d. Storm drain inlet capacity shall be calculated using the following clogging factors:

- Grated openings in sag - 50% clogged
- Grated openings on a continuous grade - 40% clogged
- Curb openings in a sag - 20% clogged
- Slotted drains on grade - 20% clogged
- Slotted drains in sag - 50% clogged
- Combination inlets - use appropriate clogging factors shown above for each component of the inlet

(1) Design Criteria for Small Diameter Storm Drains - Storm drains having pipes 48 inches in diameter or smaller shall be designed to the following criteria:

(a) Manholes or catch basins are to be located at all changes in direction of pipes, slope of pipes, or pipe junctions.

(b) Maximum manhole spacing to be 500 feet.

(c) Pipes must have at least three feet of cover above the top of the pipe. If less than three feet of cover is provided, pipe material shall be concrete. A minimum of 2 feet of cover is permitted at catch basins if the depth of cover increases to three feet within 10 feet of the catch basin.

(d) These design criteria shall apply to small diameter lateral pipes that discharge to a large diameter trunk line.

(e) Pipes to be installed in accordance with City of Sierra Vista Trench Detail.

(2) Design Criteria for Large Diameter Storm Drains - Storm drains having pipes larger than 48 inches in diameter shall be designed to the following criteria:

(a) Maximum manhole spacing to be 800 feet.

(b) Manholes are to be located within approximately 20 feet from bends having an angle greater than 60 degrees from the tangent alignment. Maximum spacing criteria shall be applied to bends less than 60 degrees.

(c) Bends in trunk lines may be prefabricated pipe sections or made in the field by cutting the pipe and installing a pipe collar per MAG Standard Detail 505. If pipe collars are used the pipes to be joined shall be trimmed so that no gaps larger than 12 inches remain between the pipe sections when they are fitted together.

(d) Manholes shall be in accordance with MAG Standard Detail 521. The 4-foot diameter riser shall be a prefabricated TEE section. The trunk line may not be field cut to install manhole risers.

(e) Lateral pipes that intersect the trunk line may be field fit if the inside diameter of the smaller pipe is less than one-half the outside diameter of the trunk line. If the inside diameter of the smaller pipe is more than one-half the outside diameter of the trunk line, the connection shall be made with a prefabricated TEE. Field connections shall be trimmed smooth and sealed neatly from the inside of the trunk line. Connection shall be made watertight by using a concrete encasement, field welding, or a factory made attachment collar.

(f) Lateral pipes intersection trunk lines shall be connected so that the smaller pipe is radial to the trunk line.

(g) Pipes to be installed in accordance with City of Sierra Vista Trench Detail.

(h) Pipes must have at least three feet of cover above the top of the pipe. If less than three feet of cover is provided, pipe material shall be concrete.

10. Erosion Protection and Energy Dissipation. Design of open channels, storm water basins, and improvements in washes shall incorporate adequate erosion

protection and energy dissipation. Design of erosion protection shall address potential scour depths, bed and bank erosion, bend erosion, and long-term effects of proposed improvements. Improvements in washes shall not have an adverse impact on other property owners, including the City of Sierra Vista. Improvements are to be designed using the following considerations:

- a. Peak flow to be 100-year, 1-hour design storm. However, design of erosion protection incorporating hydraulic jumps or spillways shall consider effects of 10-year and 25-year design storms as well.
- b. Proposed improvements in washes designated as FEMA floodplains shall be approved through FEMA by obtaining a Conditional Letter of Map Revision (CLOMR) before construction and a Letter of Map Revision (LOMR) after completion of construction.
- c. Design of erosion protection and energy dissipation structures shall incorporate whatever materials are necessary to withstand design conditions. However, concrete and grouted rip rap are to be avoided whenever possible.
- d. Design criteria of other portions of the Development Code shall be followed when designing these structures.
- e. Erosion setbacks from washes may be used in lieu of armoring with the approval of the City Engineer.
- f. Setbacks from existing or future drainage ways shall be as allowed per Section 151.22.029.D, erosion setback distances shall be as calculated using the procedure described Section 7.6 of the Standards Manual for Drainage Design and Floodplain Management in Tucson, Arizona, 1998 Revision. Use of erosion setbacks shall be guided by the requirements of the Surface Water Plan. Preservation of the riparian vegetation zone is encouraged wherever possible. Substitution of setbacks for the preservation of the riparian vegetation zone, in lieu of channel improvements, may be allowed in Flood Erosion Control Corridors, if approved by the City Engineer.
- g. Requirements of this section do not apply to components of Storm Water Pollution Prevention Plans (SWPPP) required by the Arizona Department of Environmental Quality.

11. Design of Improvements in Regional Washes. Regional washes are defined as those washes addressed in the Surface Water Plan (SWP). The SWP has determined the hydrology information to be used to design and construct the drainage improvements necessary to capture, control, and convey storm water runoff through the City. Developers should consult the SWP to identify the recommended locations and sizes of regional drainage facilities, and recommended improvements as they affect new development. Specifically, the Surface Water Plan identifies potential locations for regional detention basins; defines Natural Drainage Maintenance Corridors (NDMC); defines Flood and Erosion Control Corridors (FECC); and designates regional washes as NDMCs and FECCs. The SWP makes the following recommendations regarding NDMCs and FECCs:

a. Natural Drainage Maintenance Corridors (NDMC). Natural Drainage Maintenance Corridors (NDMCs) have been established at the locations recommended by the Surface Water Plan. Said locations have been established in undeveloped areas, within open space/ recreation areas, or where channel velocities in developed areas have been determined to be low. The purpose for the NDMC is to maintain a continuous flood hazard and erosion hazard buffer along established channels. Preservation of the mature riparian environment along the channel should provide a natural stabilizing influence and reduce erosion. The most restrictive of the following setbacks shall be established and maintained.

(1) The 100-year floodway.

(2) The limits of the riparian vegetation zone, as determined by recent aerial photographs.

(3) A 50 foot setback from each bank of the low flow channel for watersheds less than or equal to 1.5 square miles; or a 100-foot setback from each bank of the low flow channel for watercourses draining watersheds greater than 1.5 square miles.

b. Flood and Erosion Control Corridors (FECC). FECCs have been established at the locations recommended by the Surface Water Plan. Said locations have been established where no defined channel or wash exists, and where the drainage is predominantly uncontrolled and has sheet flow characteristics. The purpose of establishing a FECC is to determine and designate the location, direction of flow, and required setbacks for future drainage improvements. A detailed determination of the FECC limits shall require floodplain mapping. The limits of the Flood and Erosion Control Corridor (FECC) shall be determined as follows:

(1) Up to a 100-foot wide drainage way centered within the FECC, that would allow for any drainage improvements necessary to control and convey the flows determined to be contributed by the upstream watershed upon ultimate development upstream.

(2) Setbacks for flood and erosion protection shall be established at a distance of 50 feet from each side of the drainage way for watercourses draining watersheds up to and including 1.5 square miles.

(3) Setbacks for flood and erosion protection shall be established at a distance of 100 feet from each side of the drainage way for watercourses draining watersheds greater than 1.5 square miles.

(4) The setbacks identified in items 2 and 3 may be reduced depending on drainage characteristics and the nature of the proposed improvements, as determined by the City Engineer. At a minimum, a 20-foot maintenance access easement shall be required on one side of the drainageway.

c. Information included in the Surface Water Plan is to be considered as preliminary planning information only. Design of regional facilities shall be based on the best information and data available. Regional storm water facilities are subject to the following considerations:

(1) Where development occurs downstream prior to the construction of upstream drainage improvements identified in the Surface Water Plan, the developer shall construct the necessary drainage improvements such that the improvements are capable of controlling and conveying the existing flows for the 100-year storm.

(2) Developers have the option of constructing upstream improvements to satisfy the intent of the Surface Water Plan, if approved by the City Engineer. The upstream improvements must be adequate to protect the developed parcel free of flood damage during the 100-year storm and the design criteria specified herein must be satisfied.

(3) Armoring on one bank of a regional wash will not be permitted.

12. Storm Water Basins, General. Storm water basins shall be used to detain/retain storm water from new development as follows:

a. Storm water runoff shall be detained/retained so that there is no increase in undeveloped peak flows from the site after development. The pre-development and post-development peak flows from the 10-year and 100-year, 1-hour storms shall be evaluated to determine compliance.

b. Where existing improvements such as parking lots exist, the requirements of this section apply and the new development will be treated as development on previously undisturbed ground in terms of stormwater detention/retention requirements.

c. Whenever feasible, storm water basins should detain flows rather than retain flows. Retention basins will not be permitted if it is feasible to discharge flows from the basin through a discharge pipe into a public street right-of-way, dedicated drainageway, or improved drainage easement that has the capacity to convey the flow.

d. Basins shall be designed to drain all runoff associated with the 100- year, 1-hour storm within 72 hours. Removal of runoff from the basin may be through percolation/infiltration or through a discharge pipe into a public street right-of-way, dedicated drainageway, or improved drainage easement that has the capacity to convey the flow. If the basin is to be drained by percolation/infiltration alone, percolation calculations stamped by geotechnical engineer registered in the state of Arizona are required.

e. Preliminary percolation tests shall be performed during the design stage of the basin at the ultimate finish grade of the bottom of the basin.

f. Basins that are designed to retain stormwater shall be scarified at the end of the construction period to maximize percolation capacity. At a minimum, basins shall be seeded with native grasses upon completion of construction.

g. Drainage runoff to be detained/retained on site. Storm water basins may not encroach City street right-of-way, dedicated washes or drainage easements (does not include area specifically platted as the storm water basin within a single family residential subdivision), FEMA floodplains, erosion setbacks, or Natural Drainage Maintenance Corridors.

h. Storm water basins shall be equipped with an emergency overflow weir. Water discharging from the weir shall flow directly into a public street right-of-way, dedicated drainageway, or improved drainage easement that has the capacity to convey the flow. The weir and the pathway to the discharge point shall be open and not prone to clogging under reasonable circumstances. Pipes shall not be used to meet the emergency overflow requirement. The weir shall be armored to resist erosion that could be caused by 20% of the 100-year peak flow.

i. Minimum diameter of discharge pipe shall be 18 inches. An orifice plate on a concrete headwall may be used to reduce the discharge from the pipe. This provision is recommended, but not mandatory for basins located in commercial, industrial, or multi-family developments.

j. Basin inlets and outlets shall be protected from erosion associated with the peak flow for the 100-year, 1-hour storm.

k. Where stormwater detention/retention cannot be located on site, off-site detention/retention may be permitted provided it is within the same watershed or subwatershed, as determined by the City Engineer.

13. Storm Water Basins, Single Family Residential. Storm water basins shall be used to detain/retain storm water from new single family residential developments as follows:

a. In single family residential subdivisions, whether public or private, the land occupied by the storm water basins shall be dedicated to the City for public use on the plat. The developer shall maintain the basin until the entire subdivision is developed and improvements are accepted by the City, at which time the City will assume maintenance responsibilities.

b. Wherever practical, all runoff from a subdivision shall be detained at a single basin.

c. Maximum water depth in basin shall be 3 feet. All basins shall be provided with one foot of freeboard above the maximum water surface elevation.

d. Maximum side slope shall be 4:1 (horizontal to vertical).

e. The City may accept storm water basins in single-family residential subdivisions as recreational facilities provided any appurtenances such as recreational equipment, ramadas, landscaping, etc., are approved by the City for future maintenance considerations. Improvements not acceptable to the City may not be installed.

f. Storm water basins on individual lots will not be permitted in subdivisions in lieu of a single basin.

g. At a minimum, basins shall be seeded with native grasses upon completion of construction.

h. Basin design and construction shall include provisions for adequate access to all improvements for maintenance.

14. Storm Water Basins, Commercial. Storm water basins shall be used to detain/retain storm water from new commercial, industrial, or multi-family developments as follows:

a. Individual storm water basins shall be installed at all new commercial, industrial, and multi-family developments.

b. Basins associated with commercial, industrial, and multi-family developments shall be owned and maintained by the property owner.

c. Parking areas may be used wholly or in part to detain storm water within commercial developments providing the following criteria are met:

(1) Detained water shall not be held on public pavement or encroach public improvements.

(2) Depth of detained water shall not exceed 9 inches within designated parking spaces.

(3) A non-clogging emergency overflow weir shall be provided to prevent water from exceeding a depth of 9 inches in designated parking spaces.

Predetermined Detention Basin Sizes						
Commercial Sites in Sierra Vista						
Basin Depth 3 Feet With 1 Foot of Freeboard						
Site Area (acres)	Pre-Development Peak Flow (cfs)	Post-Development Peak Flow (cfs)	Discharge Opening Diameter (in)	Basin Bottom Area (sf)	Basin Top Area (sf)	Volume (cf)
0.5	1.2	2.8	6	200	1,400	2,400
1.0	2.3	5.5	8	600	2,400	4,500
1.5	3.5	8.3	9	1,100	3,300	6,600
2.0	4.7	11.1	10	1,700	4,200	8,850
2.5	5.8	13.8	12	2,100	5,000	10,650
3.0	7.0	16.6	13	2,600	5,700	12,450

3.5	8.2	19.4	13	3,100	6,700	14,700
4.0	9.3	22.1	14	3,500	7,400	16,350
4.5	10.5	24.9	15	4,300	8,200	18,750
5.0	11.7	27.7	16	4,700	8,600	19,950
5.5	12.8	30.4	17	5,400	9,800	22,800
6.0	14.0	33.2	18	5,800	10,500	24,450

15. Harvested Storm Water Detention, Commercial

Rainwater harvesting as a means to address stormwater detention requirements is allowable. The City adheres to the Best Management Practices found on the University of Arizona Extension Office Water Wise website (waterwise.arizona.edu).

a. Storage of rooftop and/or parking lot runoff may be used to offset the required capacity of detention/retention basins. An analysis of the capacity of the storm water collection system shall be included in the hydrology report/statement. Depending on tank(s) capacity, portions, or all, of the roof area may be deductible from the site area for purposes of storm water calculations. The following criteria shall apply:

(1) Harvested water shall be used for site landscape irrigation only, preferably instead of groundwater irrigation.

(2) Multiple tanks may be used.

(3) Above ground tanks may be used but must be sealed as per the BMP's to prevent mosquito breeding.

(4) Underground tanks may be used but must be sealed as per the BMP's and a pumping system utilized.

(5) Other design parameters shall meet the BMP's.

b. Parking lot runoff directed to landscaped water harvesting basins ("passive water harvesting") may be used to offset the required capacity of detention/retention basins. An analysis of the capacity of storm water captured shall be included in the hydrology report/statement. The following criteria shall apply:

- (1) Basin depth must be a minimum of 6 inches.
- (2) Basin depth shall not exceed 18 inches.
- (3) Side slopes shall be no steeper than 3:1.
- (4) Storm water must percolate into the ground within 72 hours.
- (5) Landscaping in the basins can count toward the 15 percent site landscaping requirement per Article 151.15.
- (6) Discharge of storm water from basins, whether by design or by overflow, shall not allow outflow of groundcover materials into parking lot, public sidewalk or streets.

F. Drainage Runoff Discharge Planning

1. Storm water shall be conveyed through a development or subdivision in a manner that will not damage improvements within the development or subdivision nor create an undue nuisance to the inhabitants thereof. When improvements within a development or subdivision change the natural flow of storm drainage, they shall be designed in a manner that will not damage the land or change the flow characteristics of the natural drainage over the land upstream or downstream from the development or subdivision.

2. All new developments shall accept upstream drainage runoff from adjacent undeveloped land to preserve the historical flow direction and pattern, in accordance with Title 45 of the Arizona Revised Statutes. Upon development, the adjacent upstream public or private property shall comply with the requirements of this section.

3. Upon development of a private lot that receives offsite runoff, provisions shall be made to safely collect and convey the offsite runoff across the lot. If available, the runoff shall be discharged to a downstream public drainageway or into a drainage easement dedicated to the public. In the event the runoff must be discharged onto another private lot, the runoff shall be discharged in the location that historically received the runoff. The owner of the lot being developed shall grant an easement to the public to convey the offsite flows to the discharge point. If future upstream development is expected to eliminate the encroachment by offsite runoff, the drainage easement may be temporary. Temporary drainage easements shall be set to expire contingent upon the expected upstream development. Detention or retention of offsite water is not required.

4. In the event that the developer is not able to discharge to a dedicated drainageway or a drainage easement, the developer shall attempt to obtain a drainage easement from the downstream owner. If the downstream owner landowner refuses to grant an easement, the developer shall provide a copy of a certified letter sent to the downstream landowner advising him of the developer's rights under Title 45 of the Arizona Revised Statutes.

5. Once runoff has been collected in a conveyance (wash, street, channel, storm drain, ditch, etc.) owned by the City of Sierra Vista, it shall remain within a public easement. Discharge of storm runoff from a dedicated easement onto private property

is prohibited. Storm water within a public easement must always be discharged into another public drainageway or into a drainage easement dedicated to the public.

6. All concentrated storm drainage that cannot be conveyed in a public street right-of-way shall be conveyed in a dedicated drainage way or in an improved (paved) drainage easement. Dedicated drainage ways shall be vested in the public for public use and to construct, operate, and maintain improvements for the control and conveyance of storm water and for recreational area purposes. Drainage ways shall not be included in any lot. Drainage easements are dedicated for public use, but the right to use them to construct and maintain drainage facilities shall be granted to the public and they may be included in a lot. The use thereof shall be restricted to uses that will not interfere with the maintenance of the natural flow of storm drainage over and/or under the easement. All drainage easements and dedicated drainageways shall be at least 20 feet in width. A drainage way shall be provided and so designated when the expected flow for the 100-year storm exceeds (100) cfs, or cannot be conveyed within the minimum drainage easement width. Both drainageways and drainage easements shall be provided to accommodate the flow expected to occur at least once every 100 years, plus one foot of freeboard, or as described herein.

G. Design Detail Documents Allowed

1. Design Documents

The following documents provide guidance for the design and construction of drainage facilities and shall be used to fulfill the standards in this Section.

a. The Surface Water Plan for the City of Sierra Vista, Volumes 1 through 3, written by Simons, Li & Associates, Inc., hereinafter called Surface Water Plan.

b. The Development Code for the City of Sierra Vista.

c. Uniform Standard Specifications for Public Works Construction and the Uniform Standard Details for Public Works Construction as compiled by the Maricopa Association of Governments, hereinafter called MAG Specifications.

d. City of Sierra Vista Engineering Design and Construction Standards as compiled.

e. The Highway Drainage Design Manual, ADOT, 1993.

f. Current version of the (DRAFT) Drainage Design Manual, for Maricopa County, Arizona, Hydraulics, Flood Control District of Maricopa County. In the event Maricopa County adopts the draft manual, that version shall be used. The current Maricopa County Hydraulics Manual (January 26, 1996 version) shall not be used.

g. Standards Manual for Drainage Design and Floodplain Management in Tucson, Arizona, 1998 Revision.

h. The City Engineer may allow the use of other documents for the design and construction of public drainage improvements or facilities, as necessary, should the

information or details necessary to complete the design or construction not be covered by any of the above references.

2. Document Conflict

In case of conflict between the referenced documents, the City Engineer shall determine the applicable design or construction requirements. In general, the more stringent or conservative requirement will be applied.

H. Variance Procedure for Alternative Drainage Designs

Should special conditions exist on the property that make meeting the detention basin requirements difficult, an alternative drainage design can be submitted to the City. Permission will not be granted until submittal of a written application demonstrates the following:

1. That special conditions and circumstances exist which are peculiar to the land or proposed structure(s) involved and which are not applicable to other lands or structures in the area.
2. That the alleged hardships caused by literal interpretation of the provisions of this code do not result from the actions of the applicant.
3. That granting permission to build an acceptable alternate drainage control structure will not confer upon the applicant any special privilege that is denied by this code to other lands or structures in the same area.
4. That granting permission to build an acceptable alternate drainage control structure will not interfere or injure the rights of other properties in the same area.
5. The application shall contain:
 - a. Written text fully describing the special conditions and circumstances prompting the request.
 - b. Drawings with enough detail and dimension to fully demonstrate how the proposed acceptable alternate drainage structure will meet the requirements of this code.

(’76 Code, Art. 12-1) (Ord. 743, passed 4-10-86; Am. Ord. 834, passed 3-9-89; Am. Ord. 875, passed 1-10-91; Am. Ord. 925, passed 8-12-93; Am. Ord. 990, passed 10-26-95; Am. Ord. 1022, passed 12-12-96; Am. Ord. 1043, passed 9-11-97; Am. Ord. 1049, passed 11-13-97; Am. Ord. 1149, passed 9-26-02; Am. Ord. 2003-005, passed 2-13-03; Am. Ord. 2012-004, passed 6-28-12)

Section 151.08.0069 Easement Planning

A. Utility Easements. The developer shall provide utility easements as required by the serving utilities and is responsible for coordinating such with the utilities concerned. Sewer easements shall be a minimum of 20 feet wide with no structures or walls being

placed over them. In areas where vehicular access is to be restricted, a gate shall be placed according to Public Works Engineering Standard drawings.

B. Curvilinear Alignments. For lots facing on curvilinear streets, utility easements, or alleys shall usually consist of a series of straight lines with points of deflection not less than 120 feet apart, said points of deflection always occurring at the junction of side and rear lot lines on the side of the exterior angle. However, curvilinear easements or alleys may be employed providing that the minimum radii of centerlines are not less than 800 feet.

C. Drainage. Dedicated drainageways or drainage easements shall be provided for surface drainage courses abutting or crossing the tract in accordance with Section 151.08.008, and shall be of a width sufficient to permit vehicle access for maintenance, widening, deepening, relocating, or protecting such drainage course as may be required by the Director of Community Development.

D. Non-Vehicular Access Easements. Lots arranged to back to a commercial or industrial district or to an arterial street shall have a recorded non-vehicular access easement one foot wide along the rear or side lot line.

('76 Code, Art. 12-1) (Ord. 743, passed 4-10-86; Am. Ord. 875, passed 1-10-91; Am. Ord. 1043, passed 9-11-97; Am. Ord. 2012-004, passed 6-28-12)

Section 151.08.007~~40~~ Streetlight Design and Construction

A. General Requirements

1. Developers of new subdivisions, commercial, and industrial projects, or major additions thereto, are responsible for the design, materials, and installation costs of all streetlighting on all public streets within and adjacent to their project. This requirement applies to both improved and unimproved public right-of-way, adjacent to development site. The City of Sierra Vista will pay all costs associated with providing ongoing electrical service after the City approves activation of the streetlights.

2. Streetlighting plan approval and expiration parallels site plan and/or subdivision plat approval and expiration and requires re-submittal if the improvement plans are updated.

3. Adherence to the designed pole locations is expected. Exceptions may be granted for shifts up to 10± feet parallel to the roadway due to field conditions. Where underground obstructions are encountered, any shift in pole placement must not interfere with a driveway and/or ADA accessibility. Shifts perpendicular to the roadway from permit locations will not be allowed without an approved plan revision.

4. Private streetlights should be labeled as such. Private streetlights are permitted only on private streets and must conform to all applicable City of Sierra Vista lighting ordinances.

5. These regulations do not apply to private onsite development, which must adhere to Development Code Article 151.11.

B. Design Guidelines

1. The public streetlight system shall be installed in the right-of-way. Where right-of-way is not available and where a public utility easement allows for streetlight equipment, the engineer may design equipment within the easement with approval from the City of Sierra Vista. The developer will be required to provide a new public utility easement, if the existing right-of-way or easement is not sufficient to encompass the new improvements.

2. Streetlight layout and design shall include existing and known future streetlight location information for all streets within and adjacent to the proposed development. Streetlight poles and equipment should be shown with station and offset dimensions. In addition, the following information shall be identified, located, sized, and dimensioned from the center line and/or monument line:

- a. Existing and proposed utilities (overhead or underground).
- b. Face of curb.
- c. Width of sidewalk.
- d. Width of any public utility easement (PUE).
- e. Edge of right-of-way.
- f. Edge of pavement.
- f. Driveways and handicapped ramps.
- g. Any structures that may interfere with streetlight placement.

3. There should be a minimum of three (3) feet of clearance between streetlight poles and other utilities.

4. Design conflicts shall be resolved by the design engineer to the satisfaction of the electrical utility company and the City. It shall be the design engineer's responsibility to coordinate conflict resolution with electric utility company facilities, including vertical clearances without compromise to the uniformity in the lighting design.

5. Public streetlighting plans will show luminaire and pole type and lumen levels. Streetlight equipment shall conform to approved manufacturers per current utility company and City standards. For streetlights that will be owned and maintained by the local utility company, Sulphur Springs Valley Electric Cooperative, the developer shall be responsible for coordinating streetlighting design with SSVEC. In all cases, the developer will need to coordinate electrical service design with SSVEC.

6. In an effort to achieve reasonable uniformity, deviations away from the specified point of radius are permitted up to 25 feet. Any further deviation must be documented and based on unusual roadway conditions.

7. All poles are to be located approximately 1-foot behind the sidewalk where the sidewalk abuts the curb. Where the sidewalk is detached to create a landscaped area, poles are to be located within the landscaped area, with an easement of adequate width for the public improvements if insufficient right-of-way is available. In no case shall a streetlight be placed within a sidewalk or multi-use path.

8. In areas where standard vertical curb, roll curb or sidewalk does not exist, all poles shall be centered at least ten (10) feet from the edge of the roadway.

9. A new streetlight conforming to the requirements of this section shall be placed along the public right-of-way at each multi-family residential, commercial, and industrial driveway unless there is an existing streetlight located within 100 feet. Parking lot lights may not be used to meet this requirement unless extraordinary conditions exist, as approved by the City.

10. Efforts shall be made during the design stage to assure that two (2) streetlights are located diagonal across the intersection from each other at each arterial street intersection and one streetlight at all other intersections, unless compliance is infeasible, in which case the required streetlights shall be located as close to the intersection as practicable.

11. All street light poles shall be thirty (30) feet in height, unless otherwise permitted, and shall utilize metal standards. Wooden standards are not permitted.

12. Although the City currently uses high pressure sodium (HPS) streetlights and solar street lights, other new technologies (solar, light emitting diode, etc.) will be considered on a case by case basis. The use of alternative technologies is primarily for use on local streets, with consideration being given to other street classifications.

13. Streetlights shall be fully shielded. Additional back shields will be required for streetlights on arterial and collector roadways which are adjacent to residential zoning districts or residential developments.

C. Arterial Streets

Streetlights shall be placed at all intersections and spaced every 200 to 250 feet using 30,000 lumen high pressure sodium lighting. Arterial streets will be lighted on two sides using staggered spacing. Ideal spacing is 200 to 250 feet along the same side of the street; 100 to 150 feet between streetlights on opposite sides of the street.

D. Collector Streets

Streetlights shall be placed at all intersections and spaced approximately 200 to 250 feet apart using 16,000 lumen high pressure sodium lighting. Collector streets will be lighted on two sides using staggered spacing, unless unusual conditions are present in which case lighting on one side of the street may be permitted. Ideal spacing is 200 to 250 feet along the same side of the street; 100 to 150 feet between streetlights on opposite sides of the street.

E. Local Streets

Streetlights shall be placed at all intersections and spaced approximately 250 feet apart using 9500 lumen high pressure sodium lighting. In residential areas, midblock streetlight poles should be placed within one foot laterally from the divisional property line.

Any public street cul-de-sac having a depth of one hundred fifty (150) feet or greater from the face of the nearest curb of the intersecting street to the cul-de-sac radius point will have a streetlight or lights located in the cul-de-sac.

('76 Code, Art. 12-1) (Ord. 743, passed 4-10-86; Am. Ord. 875, passed 1-10-91; Am. Ord. 1043, passed 9-11-97; Am. Ord. 2008-004, passed 1-24-08; Am. Ord. 2012-004, passed 6-28-12)

Section 151.08.008~~44~~ Utility Trench Backfill Requirements

A. General Requirements

An important and high priority goal of the City of Sierra Vista is to assure proper utility trench backfill operations within public streets and/or rights-of-way when trenching is allowed. MAG Specifications (Section 601) is the basic premise used by the City to control backfill operations, and for developing a utility trench backfill policy that will minimize trench settlement and street repair costs to the City.

Utility trenching in public rights-of-way can be categorized under three different situations:

1. Trenching outside of an existing or proposed street prism.
2. Trenching within an existing street prism.
3. Trenching within a proposed street prism to be constructed as part of a new development/subdivision.

A street or roadway prism is defined as any existing or proposed pavement, curb, gutter, sidewalk, or such construction specified in a construction contract, or when any part of the trench excavation is within two feet of the improvements previously mentioned.

Utility trench excavation, pipe bedding, and shading requirements for trenching activities conducted under any of the three categories previously mentioned shall comply with MAG Specifications outlined in Section 601. However, utility trench "backfill requirements," as outlined in MAG Specifications under Section 601, are hereby modified below for each of the three utility trench categories in order to achieve and maintain the City's goal of minimizing utility trench settlements and street repair costs caused by failed utility trench crossings.

B. Utility Trench Backfill Requirements Outside an Existing or Proposed Street Prism

Utility trench excavations and backfill requirements pertaining to mainline sewers, lateral sewer lines, water, power, gas, telephone, and cable underground installations that lie outside and/or parallel to an existing or proposed street prism, but are located within a public utility easement, public street right-of-way, or unpaved alley, shall conform with MAG Specifications, as modified by the following requirements:

1. Utility Trench Backfill Material.

a. Native material may be used as backfill material in utility trenches in unpaved alleys and in public utility easements provided the native material meets the following criteria:

(1) Material is free of broken concrete, broken pavement, rubbish, chunks of clay, wood, organic material, or other deleterious material.

(2) Material does not contain rock or stones larger than three inches.

(3) Offsite material will qualify as acceptable native material if it meets this criteria and is identified in the native fill report.

b. Aggregate base course (ABC) complying with MAG Specifications, Section 702, may be used as backfill material in trenches in unpaved public alleys or in public utility easements.

c. Non-shrink, cement slurry mix with a minimum 28-day compressive strength of 100 psi, but not more than 150 psi, may be used as a backfill material in trenches in unpaved public alleys or in public utility easements, provided a slurry mix design, as prepared and submitted by a civil engineering materials testing laboratory is approved by the City Engineer.

2. Placement and Compaction of Utility Trench Materials

a. A selected backfill material meeting the criteria listed under A., above, shall be processed, placed, and compacted with construction equipment furnished by the contractor. Compaction equipment will be determined adequate provided the material can be placed and compacted in horizontal lifts not exceeding two feet in depth for ABC backfill material, or one foot for native material, and the required moisture and density can be achieved throughout each lift. Non-shrink, cement slurry backfill material may be placed in the entire depth of the trench up to within 18" of finished grade. The last 18" may be compacted native material or ABC.

b. The minimum percent compaction for native material or ABC material placed outside the roadway prism shall be 95% relative to the maximum density determined in accordance with AASHTO T-99, up to finished grade.

c. No water consolidation, jetting or "settling" will be allowed as a means of trying to achieve compaction.

d. The method of compaction of backfill material shall be with mechanical work methods using equipment such as rollers, pneumatic tamps and hydro-hammers,

pneumatic sheep's foot, or other approved devices which secure uniform and required density without injury to the pipe or related structures.

3. Minimum Quality Control Testing Requirements

a. A civil engineering materials testing firm/company licensed in the State of Arizona shall be retained by the contractor/developer to provide quality control testing during utility trench backfilling operations. Materials testing technicians shall be certified by the National Institute for certification in Engineering Technologies (NICET). Their certification shall be in the field of Construction Materials Testing and sub-field of Soils. The technician shall work under the direction of a professional engineer who is licensed in the State of Arizona and employed on a full-time basis by the same company.

b. As a minimum, the following number of tests are to be performed during full-time observation and testing of the backfill operation:

(1) One field density test per lift for every 400 feet (horizontally) of trench, but not less than one density test per lift for shorter trenches.

(2) The field density test shall be taken at every one-foot lift (vertically) of native backfill material, or one every two-foot lift (vertically) of ABC backfill material, starting 18 inches above the top of the pipe shading material. The density tests shall be staggered in order to distribute testing throughout the lifts of backfill material placed in the trench.

(3) One maximum density (Proctor) test for each soil type of native backfill material encountered. One maximum density (Proctor) test and one PI for each source of ABC backfill material used.

Field density testing shall be performed in accordance with either ASTM D1556 with AASHTO T-217 or ASTM D2922 with D3017 or AASHTO T-217.

c. Two field cylinders of non-shrink backfill slurry mix shall be collected and compression- tested for every 18 cubic yards placed.

d. Results of any failing quality control tests shall be reported immediately to the Public Works Construction Inspector so remedial action can be relayed to the contractor. Written results of all quality control test results shall be sent to the Public Works Construction Inspector within five working days from the date the tests were taken.

4. Workmanship Guarantee

The contractor shall guarantee the utility trench backfill work for a period of two years from the date the Right-of-Way Permit is signed by the Public Works Construction Inspector as being completed. The guarantee shall protect against any trench settlement and repair any settlement at no cost to the City.

C. Utility Trench Backfill Requirements Within an Existing Paved City Street Prism

Utility trench cuts within any existing paved City street or alley, if allowed by Right-of-Way Permit, shall be performed in accordance with MAG Standard Detail 200 ("T" Top Pavement Replacement Detail) and the following requirements:

1. Utility Trench Backfill and Pavement Materials

a. Backfill material shall be aggregate base course (ABC) complying with MAG Specification 702. A non-shrink, cement slurry mix may be considered as a suitable backfill material on local, low volume streets or alleys, if approved by the City Engineer. Native material will not be allowed as an acceptable backfill material under existing paved City streets or alleys.

b. Asphalt concrete pavement material shall be a hot dense-graded asphaltic concrete mix complying with MAG Specification 710 (D-1/2), or as may be approved by the City Engineer. A cold asphaltic concrete mix may be used as a temporary pavement patch if a hot asphaltic concrete mix is not readily available and hot mix is placed immediately upon availability.

2. Placement and Compaction of Utility Trench Materials

a. All existing asphalt shall be saw cut and removed.

b. ABC backfill material shall be uniform in gradation, have suitable moisture content to obtain minimum specified density, and may be placed in lifts not exceeding two feet in thickness. The backfill material should be placed and compacted with suitable compaction equipment that will achieve a minimum of 95% of the maximum density determined in accordance with AASHTO T-99 from 18 inches above the pipe/ conduit to a level of two feet below finished surface. ABC backfill material placed two feet below the finished base course shall be compacted to a minimum of 100% of the maximum density.

c. Hot mix asphaltic concrete surface course shall be placed and compacted with proper equipment in accordance with MAG Specification 321 and compacted to a minimum of 95% relative maximum density. The minimum pavement thickness shall be two inches or the thickness of the existing asphalt pavement, whichever is thickest.

d. No water consolidation, jetting or "settling" will be allowed as a means of trying to achieve compaction.

e. The method of compaction of backfill material shall be with mechanical work methods using equipment such as rollers, pneumatic tamps and hydro-hammers, pneumatic sheep's foot, or other approved devices which secure uniform and required density without injury to the pipe or related structures.

3. Minimum Quality Control Testing Requirements of Materials

a. Field density tests on ABC backfill material shall be taken, as a minimum, one for every lift of backfill material placed beginning 18 inches above the pipe/ conduit and every 50 feet or less (horizontally) of trench length. Tests shall be staggered at various

lifts in order to distribute testing throughout the lifts of backfill material placed in the trench.

b. Nuclear field density tests on asphaltic concrete material placed as a final surface course shall be taken, as a minimum, one every seven square yards of pavement area replaced. Cores may be required if thickness of the asphalt pavement replaced is in question.

c. Results of any failing quality control tests shall be reported immediately to the Public Works Construction Inspector so remedial action can be relayed to the contractor. Written results of all quality control test results shall be sent to the Public Works Construction Inspector within five working days from the date the tests were taken.

4. Workmanship Guarantee

The contractor shall guarantee the utility trench street cut for a period of two years from the date the Right-of-Way Permit is signed by the Public Works Construction Inspector as being completed. The guarantee shall protect against trench settlement and pavement deterioration.

D. Utility Trench Backfill Requirements Under A Proposed City Street Prism Within New Developments

Utility trench excavations and backfill requirements pertaining to mainline sewers, lateral sewer lines, water, power, gas, telephone, and cable underground installations that cross or lie under a proposed paved street, as designated by subdivision or development improvement plans, shall conform with MAG Specifications as modified by the following requirements:

1. Utility Trench Backfill Material

Acceptable backfill material for utility trenches in a new subdivision or development may consist of native material, aggregate base coarse (ABC), and/or a non-shrink cement slurry mix, provided the following requirements are satisfied:

a. If native material is to be used as a backfill material, a developer shall retain a civil engineering materials testing laboratory/firm licensed in the State of Arizona, and capable of analyzing existing, on-site soils and/or any soil/material that may be imported and used as backfill material for utility trenches that lie under a proposed paved street or alley. The materials engineering firm shall determine if the native soils to be used as native backfill material meet the following criteria:

(1) Material is free of broken concrete, broken pavement, rubbish, chunks of clay, wood, organic material, or other deleterious material.

(2) Material does not contain rock or stones larger than three inches.

(3) Material does not have a PI greater than 15, and the total sum of the percent passing the No. 200 sieve and the Plasticity Index (PI) shall not exceed 45.

(4) Offsite material will qualify as acceptable native material if it meets this criteria and is identified in the native fill report.

b. If the materials engineering firm determines the native soils to be suitable as backfill material, a certified report shall be submitted for approval to the City Engineer showing evidence that the soil meets the criteria stated in 1., above, specifying the optimum moisture content, and a suitable moisture content range that will result in minimum specified compaction, and any special processing procedures that may be required to achieve the minimum specified compaction.

c. Aggregate base course (ABC) complying with MAG Specifications, Section 702, may be used as backfill material.

d. Non-shrink, cement slurry mix with a minimum 28-day compressive strength of 100 psi, but not more than 150 psi, may be used as a backfill material in trenches under proposed paved local streets or alleys provided a slurry mix design, as prepared and submitted by a civil engineering materials testing laboratory is approved by the City Engineer.

2. Placement and Compaction of Utility Trench Materials

a. Based on the certified engineer's report prepared under A.2., above, native backfill material shall be processed, placed, and compacted with construction equipment furnished by the contractor. Compaction equipment will be determined adequate provided the material can be placed and compacted in horizontal lifts not exceeding 12 inches in depth, and the specified moisture content and density is obtained throughout the lift.

b. ABC backfill material shall be processed, placed, and compacted with construction equipment furnished by the contractor. Compaction equipment will be determined adequate provided the material can be placed and compacted in horizontal lifts not exceeding two feet in depth, and the required moisture and density can be achieved throughout the lift.

c. Non-shrink cement slurry backfill material shall be mixed in accordance with the approved mix design and may be placed the entire depth of the trench up to finished sub-grade of the proposed roadway.

d. The minimum percent compaction for any backfill material shall be 95% relative to the maximum density determined in accordance with AASHTO T-99, up to finished sub-grade of the proposed roadway.

e. No water consolidation or "settling" will be allowed as a means of trying to achieve compaction.

f. The method of compaction of ABC or native backfill material shall be with mechanical work methods using equipment such as rollers, pneumatic tamps and hydro-hammers, pneumatic sheep's foot, or other approved devices which secure uniform and required density without injury to the pipe or related structures.

g. The Items 1 through 6, mentioned above, shall apply to all utility crossings/installations including sewer laterals off the main sewer line that will lie under the new roadway pavement.

3. Minimum Quality Control Testing Requirements

a. A civil engineering materials testing firm/company licensed in the State of Arizona shall be retained by the contractor/developer to provide full-time, quality control observation and testing during all back filling operations. Materials testing technicians shall be certified by the National Institute for certification in Engineering Technologies (NICET). Their certification shall be in the field of Construction Materials Testing and sub-field of Soils. The technician shall work under the direction of a professional engineer who is licensed in the State of Arizona and employed on a full-time basis by the same company.

b. As a minimum, the following number of tests are to be performed during full-time observation and testing of the backfill operation:

(1) Native Backfill Material

(a) One field density test per lift for every 300 feet (horizontally) of trench, but not less than one density test per lift for shorter trenches.

(b) The field density test shall be taken at every one foot lift (vertically) of backfill material placed starting 18 inches above the top of the pipe shading material. The density tests shall be staggered in order to distribute testing throughout the lifts of backfill material placed in the trench.

(c) If other soil types are encountered, other than the soil types approved in the initial geotechnical report, then one maximum density (Proctor) test, one PI and minus 200's test shall be performed for each soil type of native backfill material encountered to determine if the native material meets the "suitable criteria" outlined under subsection A.1.

(d) Field density testing shall be performed in accordance with either ASTM D1556 with AASHTO T-217 or ASTM D2922 with D3017 or AASHTO T-217.

(2) ABC Backfill Material

(a) One field density test per lift every 400 feet (horizontally) of trench, but not less than one per trench length for shorter trenches.

(b) The field density test shall be taken at every two-foot lift (vertically) of ABC material placed, starting one foot above the top of the pipe shading material. The density tests shall be staggered in order to distribute testing throughout the lifts of backfill material placed in the trench.

(c) Field density testing shall be performed in accordance with either ASTM D1556 with AASHTO T-217 or ASTM D2922 with D3017 or AASHTO T-217.

(3) Non-Shrink Cement Slurry Backfill Material

A set of four field cylinders of non-shrink backfill slurry mix material shall be collected and compression tested for every 18 cubic yards of material placed. Minimum 28-day strength shall be 100 psi, but not greater than 150 psi.

(4) Report Requirements

(a) Results of any failing quality control tests shall be reported immediately to the Public Works Construction Inspector so remedial action can be relayed to the contractor.

(b) At the end of the project, a certified report shall be prepared by the civil engineering materials testing company/firm and shall contain, as a minimum, each of the field density test results and a letter stating that utility trench back filling operations were observed and completed in a manner that met the project specifications and Engineer's recommended backfill operation requirements. The report shall be sealed and signed by the professional engineer, and three copies submitted to the City prior to acceptance of any public works improvements for maintenance.

(5) Workmanship Guarantee

The developer and contractor shall execute a warranty agreement that will guarantee repair of any utility trench settlement under a paved roadway constructed within the development for a period of two years. The guarantee shall include costs associated with saw cutting pavement, reworking and re-compacting backfill material, restoring the pavement surface, and any other incidentals associated with repairing utility trench settlements, at no cost to the City.

('76 Code, Art. 12-1) (Ord. 743, passed 4-10-86; Am. Ord. 934, passed 10-18-93; Am. Ord. 1043, passed 9-11-97; Am. Ord. 2012-004, passed 6-28-12)

Section 151.08.00912 Bus Bench/Bus Shelter Requirements

A. General Requirements

All bus benches and bus shelters, used in conjunction with the public transit system, must meet all performance standards as set forth by the City Engineer and/or the Department of Purchasing. Bus benches may be used for the purpose of advertisement, see Section 151.10.003.P.

B. Location Requirements

1. No bus bench or bus shelter shall be located closer than 15 feet to any fire hydrant or any ingress/egress accessway. See Figure 24.

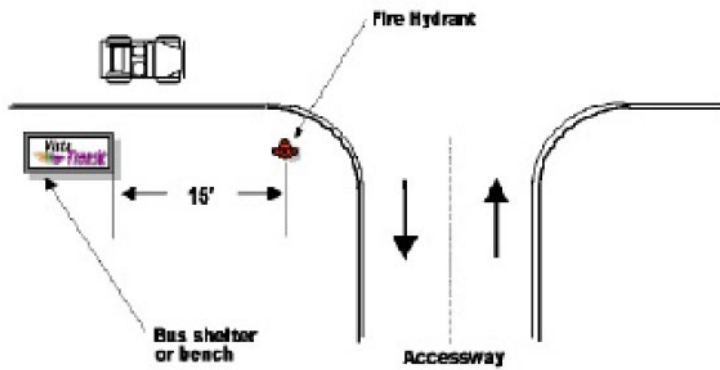

FIGURE 24

2. No bus bench or bus shelter shall be located closer than four feet from any curb line in zoning districts requiring a four foot sidewalk and no closer than five feet from any curb line in zoning districts requiring a five foot sidewalk. Also, no bus bench or bus shelter shall be located closer than five feet to any structure, see Figure 25.

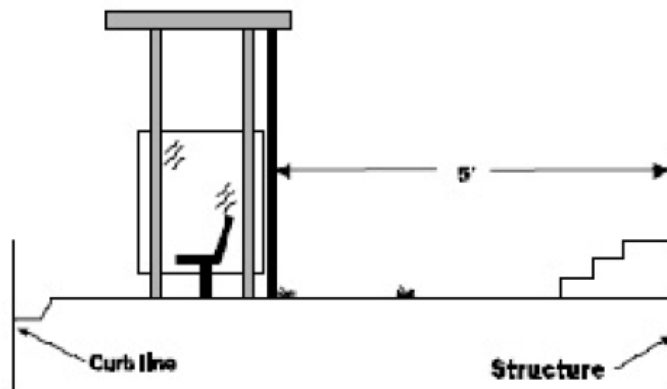

FIGURE 25

3. No bus bench or bus shelter shall be located over any utility vault, grating cellar door or utility line outlet.

4. The location of any bus bench or bus shelter may be restricted in residential areas.

5. All final locations of bus benches and bus shelters shall be approved by the city.

C. Other Requirements

No improvements allowed under this provision shall be placed in the public right-of-way without first obtaining a right-of-way permit as outlined in Section 151.08.001.F.1.

(Ord. 743, passed 4-10-86; Am. Ord. 1012, passed 7-25-96; Am. Ord. 2012-004, passed 6-28-12)

Section 151.08.010~~13~~ Wireless Communications Facilities

A. General Requirements

1. Any device mounted on or attached to City property must meet all applicable laws and codes including but not limited to NEC, FCC, UBC, MUTCD, Federal, State and Local Codes.

2. Any device and mounting and/or attachment to City property must include a professional engineering review, approval, and acceptance by the City prior to any work being performed. A right-of-way permit must be obtained through the Department of Engineering for any work performed in the public right-of-way.

3. Any incidental cost related to proprietary equipment to include but not limited to electrical power, damage, installation, and maintenance shall be borne by the proprietary equipment provider or designated agent.

4. The NEC requires telecommunications devices sharing a utility pole to be mounted a minimum of 40 inches beneath the lowest electrical wire, fixture or device. Any attachment to Sulphur Springs Valley Electric Cooperative (SSVEC) equipment requires approval from SSVEC.

5. Communications facilities shall be placed on existing structures only. The height shall not exceed 10' above the existing structure.

(Ord. 743, passed 4-10-86; Am. Ord. 1086, passed 2-11-99)

ARTICLE 151.17

Reserved for future use

ARTICLE 151.17 ACCESS STANDARDS

Sections:

- ~~—151.17.001 Purpose~~
- ~~—151.17.002 Access Points~~
- ~~—151.17.003 Access to Parking Facilities~~
- ~~—151.17.004 Access Across Parking Facilities~~
- ~~—151.17.005 Access Across Land not Owned by Developer~~

Section 151.17.001 Purpose

~~It is the purposes of this Article to coordinate development of land uses to minimize hazards, prevent traffic congestion, preserve the traffic carrying capacity of arterial and collector streets, provide a suitable location of land uses, and minimize impacts of development.~~

~~{Ord. 743, passed 4-10-86}~~

Section 151.17.002 Access Points

~~Access points to streets from all developments shall conform to the following criteria:~~

~~A. Access to Arterial Streets—General. Access onto any Arterial street from residential property shall be prohibited by the dedication of a 1-foot no-access easement along the right-of-way line as required by Section 151.08.005.B and C, and construction of a 6-foot masonry wall. There shall be no vehicular access gates in such wall. The prohibition of access by a particular use to an Arterial street may be waived by the Council upon the request of the subdivider and recommendation by the Commission, provided the subdivider can show that existing development or topography prohibits the reasonable development of an adequate frontage street or that the traffic volume accessing the property will be better served by an alternate plan as developed by a registered traffic engineer, and that the proposed alternate plan for access will preserve the traffic function of the Arterial street and protect residential properties from the nuisance and hazard of high-volume noisy traffic.~~

~~—Access criteria for each Arterial street classification should conform to the following:~~

~~—1. Principal Arterials~~

~~Access directly onto a Principal Arterial from any local street or from any abutting property shall be prohibited. An internal circulation system must be developed to provide access~~

from abutting properties to a Minor Arterial or Collector as designated on the Traffic Circulation Plan, and thence to the Principal Arterial.

~~—2.— Minor Arterials~~

~~Access directly to a Minor Arterial from any commercial or industrial property shall be limited as much as practical, and be restricted to one access per property. Access shall not be allowed within 300 feet of another access point unless existing development conditions such as existing driveway locations on adjacent properties or property boundary limits make it difficult to comply with the driveway separation requirements. In such cases, the Director of Community Development may approve driveway separations closer than 300 feet if a traffic impact analysis, prepared by a professional traffic engineer, provides justification acceptable to the City Engineer and approval is recommended to the Director of Community Development. No unrestricted access shall be allowed within 500 feet of a street intersection when measured from the intersection of ultimate street rights-of-way extended at an intersection and the center of the proposed access point.~~

~~B.— Access to Collector Streets—General. Collector streets are designed for utilization by through traffic and limited direct access from adjacent property. Access criteria for Collector streets shall conform to the following criteria:~~

~~—1.— Residential Collectors~~

~~Access directly onto Residential Collector streets by residential properties shall be discouraged.~~

~~—2.— Commercial/Industrial Collector Streets~~

~~Access from commercial and industrial uses should be limited as much as practical so as to not interfere with the through function of the street. Access should be limited to one access per property. No unrestricted access shall be allowed within 250 feet of a street intersection when measured from the intersection of ultimate street rights-of-way extended at an intersection and the center of the proposed access point. Distance between other access points should be at least 200 feet unless existing development conditions, such as existing driveway locations on adjacent properties or property boundary limits, make it difficult to comply with access separation requirements. In such cases, the Director of Community Development may approve driveway separations less than 200 feet if a traffic impact analysis prepared by a professional traffic engineer provides justification acceptable to the City Engineer and approval is recommended to the Director of Community Development.~~

~~C.— Access to Local Streets—General. Local streets are designed to discourage their use by through traffic and to provide access to adjacent property. Local streets in commercial and industrial areas should be limited to one access per property line or 25 feet from an existing driveway. Access shall not be located closer than one 150 feet from a street intersection when measured from the intersection of the abutting street right-of-way extended at an intersection and the center of a proposed access point. Local streets in commercial and industrial areas shall be designed to conform to the criteria in Section~~

~~151.08.004. All uses may take direct access to local streets. Exceptions shall be reviewed and approved by the Director of Community Development and the Development Review Committee.~~

~~D.—Joint Access. When a developer or property owner develops or redevelops property in such a manner whereby individual parcels are created and are unable to meet the access requirements above, the developer or property owner shall prepare an overall access plan for the entire property. Subject to review and approval by the City, the developer may be required to establish and record joint access agreements between individual parcels.~~

~~Where parking facilities and driveway access is shared by adjoining developments, an ingress/egress easement shall be recorded authorizing and declaring the purpose and limits of the property to be used.~~

~~E.—Existing Access Points. As of the date of the adoption of this section of the Code, existing access points onto Arterials and Collectors may be allowed to remain. If additional development occurs on properties with existing access points, the provisions of this section shall apply, and the entire site shall conform to the requirements of this section. The City may restrict existing driveways to certain turning movements by requiring the developer to construct raised medians on Arterials and Major Collector streets where development may affect the level of service, safety and through function of these major streets.~~

~~F.—Additional Access Points. No additional access points shall be permitted unless a detailed traffic study and access plan are submitted to the City for review and approval, which justifies the additional access points requested.~~

~~{Ord. 743, passed 4-10-86; Am. Ord. 764, passed 1-8-87; Am. Ord. 834, passed 3-9-89; Am. Ord. 854, passed 1-25-90; Am. Ord. 875, passed 1-10-91; Am. Ord. 1022, passed 12-12-96; Am. Ord. 1043, passed 9-11-97; Am. Ord. 1056, passed 1-8-98}~~

~~Section 151.17.003 Access to Parking Facilities~~

~~A.—Access to Parking from a Street. Access to a parking lot from a street shall be limited to driveways, and there shall be no direct access to any off-street parking space located in a parking lot from a public street.~~

~~B.—Access to Parking from an Alley. Any parking lot may use an abutting alley for direct access to parking spaces; provided that the full width of the alley is dedicated to the public and fully paved with two inches of asphaltic concrete over six inches of aggregate base course or four inches of Portland Cement concrete reinforced with #8, 6-inch by 6-inch wire mesh over a sub-base compacted to 95 percent density and property drained to prevent impoundment of surface water.~~

~~{Ord. 743, passed 4-10-86; Am. Ord. 834, passed 3-9-89}~~

~~Section 151.17.004 Access Across Parking Facilities~~

~~Every parking lot shall provide a clearly marked walkway, protected from traffic, extending from the building being served to the public sidewalk in front of the building.~~

~~{Ord. 743, passed 4-10-86}~~

~~Section 151.17.005 Access Across Land not Owned by Developer~~

~~Where primary public access must be provided across land not owned by the developer, the developer shall, as a minimum, provide at least 50 feet of dedicated right-of-way and construct sufficient paving improvements to accommodate two-way traffic (minimum 28-foot wide pavement). Exceptions may be made for private residential streets developed and constructed under the provisions of Section 151.08.004.B.~~

~~{Ord. 834, passed 3-9-89}~~

ARTICLE 151.19 SUBDIVISION, LAND DIVISION, AND LOT COMBINATION PROCEDURES AND REQUIREMENTS

Sections:

- 151.19.001 Purpose
- 151.19.002 General Requirements
- 151.19.003 Related Statutes
- 151.19.004 Subdivisions
- 151.19.005 Improvement Security
- 151.19.006 Minor Subdivisions
- 151.19.007 Minor Plat Amendments
- 151.19.008 Minor Lot Divisions
- 151.19.009 Modifications
- 151.19.010 Fees

Section 151.19.001 Purpose

- A. Assure that all minor land divisions and subdivisions are in conformance with the City's regulations regarding land development;
- B. Assure a coordinated vehicular and pedestrian circulation system;
- C. Establish minimum standards for land divisions and subdivisions;
- D. Assure that all lots or parcels are provided with infrastructure improvements and street access;
- E. Provide a consistent review process;
- F. Obtain accurate survey and permanent public record of the boundaries of lots created by the division of lands and subdivision plats;
- G. Facilitate the conveyance of land by reference to an accurate legal description by means of a recorded subdivision plat; and
- H. Provide a convenient method of describing property being conveyed.

(Res. 2020-010, passed 2-12-20; Am. Ord. 2020-003, passed 4-9-20)

Section 151.19.002 General Requirements

- A. The City shall not approve a final plat of a subdivision, land split, or lot combination unless it conforms to the provisions of this Article.
- B. No person shall sell or commence any development or construction upon any portion of a proposed subdivision until a final plat has been recorded.
- C. No person shall sell or commence any development or construction upon any portion of a proposed land split until a land split map has been recorded.

D. The provisions of this Article apply to all subdivisions (including a minor subdivision review process), and minor lot division as further described below, except for the following:

1. The sale or exchange of parcels of land to or between adjoining property owners if such sale or exchange does not create additional lots;
2. The partitioning of land in accordance with other statutes regulating the partitioning of land held in common ownership;
3. The leasing of apartments, offices, stores, or a similar space within a building or trailer park; or
4. The leasing of mineral, oil, or gas rights.

E. As used within this Article, subdivision, minor subdivision process, minor lot divisions are described as follows:

1. Subdivision:

a. A subdivision is the division of improved or unimproved land into either:

- (1) Four or more lots, tracts, or parcels of land;
- (2) Two or more lots, tracts or parcels of land, if a new street is involved; or
- (3) Three or more lots, tracts, or parcels, the boundaries of which have been fixed by a recorded plat.

b. Subdivision applications are required to adhere to a multi-step review process that includes the submission of a preliminary plat for review by the Development Review Committee before it is recommended for approval by the Planning and Zoning Commission; review and approval by the City Council; and submission of public improvement plans and a final plat for review and recommendation of the Director of Community Development and City Engineer prior to approval of a final plat by the City Council for a proposed subdivision.

2. Minor subdivision process: The minor subdivision process applies to subdivisions where a maximum of ten lots is proposed to be created; all streets forming the boundary of the subdivision are existing and improved, except for sidewalks that may be included as part of the project; all utility services are available at the subdivision site boundary; and the property is not located within a 100-year regulatory floodplain area or erosion hazard setback.

3. Minor Lot Divisions:

a. A minor lot division is the division of improved or unimproved land whose area is two and one-half acres or less into either:

- (1) No more than two lots, tracts, or parcels, the boundaries of which have been fixed by a recorded plat; or
- (2) Two or three lots, tracts, or parcels located within un-subdivided lands.

b. A minor lot division application is reviewed and approved by the Director of Community Development or designee.

(Res. 2020-010, passed 2-13-20; Am. Ord. 2020-003, passed 4-9-20)

Section 151.19.003 Related Statutes

The subdivision of land in the City of Sierra Vista is subject to the requirements and procedures of Arizona and federal law. Specifically related statutes include A.R.S. Title 9, Article 6.2 concerning municipal subdivision regulations; Title 32 concerning the sale of state lands; and Title 33 concerning condominiums.

(Res. 2020-010, passed 2-13-20; Am. Ord. 2020-003, passed 4-9-20)

Section 151.19.004 Subdivisions

Except as provided otherwise elsewhere in this Code, the preparation, submittal, review and approval of subdivision plats shall proceed through the following progressive steps:

A. Pre-Application Stage

1. The pre-application meeting provides an opportunity for the City and the applicant to review and exchange information regarding a proposed subdivision prior to the preparation and formal submittal of a subdivision plat application.

2. All applications for subdivision plats shall be prepared and processed in accordance with procedures and requirements defined in the preliminary plat application checklists, which the City will provide to the applicant at the pre-submittal meeting.

B. Preliminary Plat Stage. The applicant shall submit the following materials in support of a preliminary plat application for a new subdivision to the Department of Community Development.

1. Information Required for Preliminary Plat Submission

a. Form and Scale. Preliminary plat information shall be presented on one or more plan sheets of 24 inch X 36 inch proportions with written data entered directly thereon or contained in letters attached thereto. All mapped data for the same plat shall be drawn at the same standard engineering scale of 100 feet to the inch. A larger scale may be utilized with written permission of the Director of Community Development in situations which warrant its use as a result of a need to show detail which cannot be easily shown at a scale of 100 feet to the inch.

b. Identification Data

- (1) Notation of plat as a preliminary plat.
- (2) Proposed subdivision name, location by section, township and range, referenced by dimension and bearing to a section corner or a 1/4-section corner.
- (3) Name, address and telephone number of owner.
- (4) Name, address and telephone number of person preparing plat.
- (5) Name, address and telephone number of agent.
- (6) Scale, north point, and date of preparation including any revision dates.

(7) A location map, not necessarily to scale, shall be drawn on the preliminary plat. It shall show the street and tract lines and names and numbers of all existing subdivisions, and the outlines of acreage parcels of land adjacent to the proposed tract.

c. Existing Conditions Data

(1) Topography by the contours related to a U.S.G.S. Survey datum and shown on the same sheet as the subdivision layout. Contour interval shall be at least two feet for grades up to five percent, at least five feet for grades five to ten percent, and at least ten feet for grades over ten percent.

(2) Precise location of water wells, washes, and drainage ditches including direction of flow.

(3) Location, widths, and names of all dedicated streets, alleys, utility rights-of-way of public record, easements of record, public areas, and permanent structures to be retained within or adjacent to the tract.

(4) Name, book and page numbers of recorded plats abutting the tract or across a boundary street.

(5) Legal description by metes and bounds, boundary dimensions and acreage of tract.

(6) The approximate boundaries of all areas subject to the 100-year flood-prone area and the location, width and direction of flow of all water courses.

(7) The names of subdivisions which adjoin the proposed subdivision.

d. Proposed Conditions Data

(1) Street layout including location and width of all streets, alleys, crosswalks, easements and the proposed names of streets. Street layouts to include length and curve information.

(2) Lot layout, including scale dimension of typical lots; width and depth of all corner lots and lots on street curves; each lot numbered consecutively; total number of lots; key lots/corner lots will be identified by lot number in side legend.

(3) Location, width, and proposed use of easements.

(4) Location, extent, and proposed use of all land to be dedicated or reserved for public use.

(5) Size of each lot, in square feet or acres.

(6) Location and boundary of all existing and proposed zoning districts.

e. Proposed Phasing. A development phasing map and proposed timing schedule delineating the configuration, size in acres, and general sequence of development and dedication if the proposed subdivision is not intended to be continuously built-out in a single phase of construction.

f. Proposed Utilities. All lots shall be provided public water supply and sanitary sewage.

g. Water Adequacy. A copy of the application submitted to the Arizona Department of Water Resources (ADWR) for water adequacy determination.

h. Soil Engineering Report. A soil engineering report which shall include data regarding the nature, distribution and strength of existing soils, conclusions and recommendations for grading procedures and design criteria for corrective measures when necessary, and opinions and recommendations covering adequacy of site to be developed by the proposed grading. The soil engineering report will include suggestions concerning erosion control of the project site during construction as well as upon completion. The City Engineer shall review the report for accuracy and make recommendations to the Director of Community Development as to the acceptability of the report.

i. Site Hydrology Report. A site hydrology report in accordance with the criteria specified under Section 151.08.008 of this Code.

j. Traffic Impact Analysis. A Traffic Impact Analysis (TIA) shall be prepared in accordance with Arizona Department of Transportation Traffic Engineering Guidelines and Processes unless an exemption is granted by the City based on a determination of de minimum impact.

2. Condominium Subdivisions. A preliminary plat submittal for a condominium subdivision shall include the following additional information as required by A.R.S. § 33-1219:

- a. The name of the condominium;
- b. The boundaries of the condominium and a legal description of the real estate of the condominium;
- c. The extent of any encroachments on any portion of the condominium;
- d. To the extent feasible, the location and dimensions of all easements serving or burdening any portion of the condominium;
- e. The location and dimensions of the vertical boundaries of each unit, and each unit's identifying number;
- f. Any horizontal unit boundaries, with reference to an established datum, and each unit's identifying number;
- g. Any units with respect to which the declarant has reserved the right to create additional units or common elements, identified appropriately;
- h. The location and dimensions of all real estate in which the unit owner will only own an estate for years, labeled as a "leasehold condominium";
- i. The distance between noncontiguous parcels of real estate comprising the condominium;
- j. The location and dimensions of limited common elements, including porches, balconies, patios and entryways;
- k. Any other matters the declarant deems appropriate.

('76 Code, Art. 12-1) (Ord. 743, passed 4-10-86; Am. Ord. 834, passed 3-9-89; Am. Ord. 854, passed 1-25-90; Am. Ord. 875, passed 1-10-91; Am. Ord. 896, passed 1-23-92; Am. Ord. 954, passed 6-9-94; Am. Ord. 966, passed 2-23-95; Am. Ord. 1043, passed 9-11-97; Am. Ord. 2003-008, passed 4-24-03)

3. Preliminary Plat Approval

a. The Department of Community Development shall receive, review, and process the preliminary plat in order to determine its submittal compliance with the provisions of this Code.

b. In addition to the requirements of the preceding subsections, the applicant shall provide the Director of Community Development and City Engineer with any additional information, documents, or other material relevant to the application as required by City codes and regulations that are necessary for the Director of Community Development, Planning and Zoning Commission, and City Council to evaluate, analyze, or understand the subject matter of the application.

c. The Department of Community Development shall distribute the preliminary plat to all the following reviewers or their designees:

- (1) City Engineer
- (2) Fire Marshal
- (3) Superintendent of the appropriate school district (residential subdivisions only)
- (4) Local postmaster
- (5) Utility Companies
- (6) Public agencies that have abutting jurisdictional boundaries; and
- (7) Others as deemed necessary.

d. The Department of Community Development shall notify all property owners within 300 feet of the exterior boundaries of the proposed plat for review and comment.

e. The preliminary plat shall be reviewed to ensure compliance with all pertinent code and legal requirements, including, but not limited to, codes regulating streets, sidewalks, zoning, floodplain, drainage, grading, fire, water, and utility company regulations.

f. If the City finds that the preliminary plat requires revisions then the following procedure shall be followed:

- (1) Comments will be returned to the subdivider or subdivider's agent identifying the necessary revisions for compliance;
- (2) The subdivider shall resubmit the revised plat with response comments explaining any revisions made to the plat;
- (3) The subdivider will continue to resubmit the plat and response comments until all review comments have been satisfactory addressed.

4. Committee Action. The Development Review Committee shall hear all requests for preliminary plats following compliance with all staff review comments. The Committee may consider the requirements of this Code and other City ordinances, pertinent State regulations, and comments from other public agencies. The Committee shall recommend approval if the plat is in compliance with all applicable requirements. The Director of Community Development or designee shall coordinate and summarize the Committee's recommendation for presentation to Council.

5. Commission Action

a. Following a review and recommendation by the Committee, the Commission shall consider the plat at a regular or special meeting.

b. The Commission shall review the plat and recommend approval to the City Council if the plat complies with all applicable code requirements. The Director of Community Development or designee shall coordinate and summarize the Commission's recommendation for presentation to Council.

6. Council Action

a. After the Commission has made its recommendations, the Department of Community Development shall transmit the plat, with the Commission and staff recommendations, to the Council for its review and action. The Council can either approve or deny the plat.

b. Denial. If the Council denies the plat, the minutes shall state the reasons for the denial. The preliminary plat application may be re-filed at any time if revisions can resolve the reasons for the denial as originally proposed. The new filing of a preliminary plat application for the same plat, or any portion thereof, shall be treated as a new project and will follow the procedures and requirements specified in the Section.

7. Findings of Fact

a. Both the Commission and the Council are required to provide a Findings of Fact when recommending approval of the plat. The following Findings of Fact shall be included in the Resolution approving the plat:

(1) That the design or improvement of the proposed subdivision is consistent with the applicable general and specific plans;

(2) That the site is physically suitable for the type of development;

(3) That the site is physically suitable for the proposed density of development;

(4) That the design of the subdivision or the type of improvements are not likely to cause serious public health problems;

8. Significance of Approval

a. Approval of a preliminary plat by Council constitutes authorization for the subdivider to proceed with the preparation of the final plat and improvement plans.

b. Preliminary plat approval is subject to the following conditions:

(1) Changes in conditions such as the land's physical attributes, title conditions, ownership and similar changes that make development of the affected land in accordance with the approved plat infeasible shall require the submission of a new or revised preliminary plat.

(2) A preliminary plat expires two years from the date of council approval unless:

i. A final plat has been submitted for all or a portion of the property included in the preliminary plat in which case the preliminary plat approval shall be automatically extended for a period of two years, or

ii. An extension of time is granted by the City Council for good cause. The review of the extension request shall include an evaluation of any change in conditions within or adjoining the preliminary plat and the effect of new or current regulations on the project. Requests for a time

extension shall be submitted a minimum of thirty days prior to the expiration date in writing to the Director of Community Development; or

iii. An injunction or a court order requiring that the subdivision plat process cease. The platting process can commence, once the court order has been lifted, at the point in the review process where the plat had originally ceased.

(3) Once a final plat has been approved for a portion of the land area included within an approved preliminary plat, the approval of the preliminary plat shall be extended for the balance of the land area for a period of two years from the date of council approval of the final plat.

(4) If a preliminary plat expires prior to the submittal of an application for a final plat or prior to the submittal of a request for an extension of the preliminary plat approval, the preliminary plat shall be resubmitted as a new application. If the resubmitted preliminary plat has substantially the same design and configuration as the previously approved plat and no substantive changes have occurred in the standards and requirements, the fees associated with the new application shall be 50% of the original application fees.

('76 Code, Art. 12-1) (Ord. 743, passed 4-10-86; Am. Ord. 875, passed 1-10-91; Am. Ord. 947, passed 3-10-94; Am. Ord. 954, passed 6-9-94; Am. Ord. 1043, passed 9-11-97; Am. Ord. 2003-008, passed 4-24-03; Am. Ord. 2004-014, passed 12-9-04)

C. Final Plat Stage. The applicant shall submit a final plat application and supplemental documents as stated on the final plat application.

1. Information Required for Final Plat

a. Preparation of Final Plat. The final plat shall conform closely to the approved preliminary plat and be prepared in accordance with the provisions of this Code.

b. Medium of Presentation

(1) The final plat shall be, on a sheet or sheets of 24-inch X 36-inch proportions. All stamped or written matter, including signatures, shall be made with permanent opaque ink so that legible prints may be obtained therefrom. When the final plat consists of two or more sheets, one key map showing the relationship of the tract portions on the sheets shall be placed on the first sheet, and each sheet shall clearly indicate the sheet number and total number of sheets.

(2) The plat shall be drawn to an accurate scale of 100 feet to 1 inch. A larger scale may be used with the written permission of the Director of Community Development in situations which warrant its use as a result of a need to show detail which cannot be easily shown at a scale of 100 feet to 1 inch.

c. Identification Data

(1) Name of subdivision and location by Section, Township, Range, and County.

(2) Name, address, and registration number or seal of the registered land surveyor preparing the plat.

(3) Scale, north point, and date of plat preparation.

(4) Legend identifying the symbols utilized in the plat preparation; corner lots abutting a key lot will be identified in a legend by lot number with the following notation: "Building setback exceeds standard side yard setback (see zoning requirements)."

(5) Precise legal description by metes and bounds of tract boundaries.

d. Survey Data

(1) Boundaries of the tract fully balanced and closed, showing true point of beginning and all bearings and distances determined by an accurate survey in the fields; all dimensions expressed in feet and decimals thereof.

(2) Any exceptions within the plat boundaries located by bearings and distances measured in feet and decimals thereof determined by an accurate survey.

(3) Location and description of cardinal points to which all dimensions, angles, bearings, and similar data on the plat are referenced; two corners of the subdivision traverse shall be tied by course and distance to separate section corners or quarter section corners. The directional datum for all bearings shall be indicated by actual survey.

(4) Location and description of all physical encroachments upon the boundaries of the tract.

e. Descriptive Data

(1) Name, right-of-way lines, courses, lengths, widths of all public streets, alleys, crosswalks, and utility easements; radii, points of tangency, and central angles of all curvilinear streets and alleys; radii of all rounded street line intersections.

(2) All drainageways designated as such and dedicated to the public. All utility and public service easements including any limitations of easements

(3) The sidelines of all existing and proposed easements shall be shown by fine dashed lines. If any easement already on record cannot be definitely located, a statement of the existence, the nature thereof, and its recorded reference must appear on the title sheet. Distance and bearings on the sidelines of lots which are cut by an easements shall be arrowed or shown so that the map will dictate clearly the actual length of the lot lines. The widths of all easements and sufficient ties thereto be located definitely the same, with respect to the subdivision, must be shown. All easements must be clearly labeled and identified. If an easement shown on the map is already of record, its recorded reference must be given. If an easement is being dedicated on the map, it shall be set out in the owner's certificate for dedication.

(4) Location, dimension, and area (square feet or acres) of all lots. All lots numbered consecutively throughout the plat; exceptions and tracts shall be dimensioned and identified by letter or number. In areas subject to flooding, minimum finished first floor elevations shall be shown as may be recommended by the appropriate authority;

(5) Floodplain limits and the following text when applicable:

"Lots _____ have been identified as being partially or wholly within a flood hazard area per F.I.R.M. Map _____, revision date _____. Because flood hazard boundaries may be revised periodically, the most recent flood hazard map for this area should be reviewed to determine the exact limits and severity of potential flooding on these lots. Flood

hazard maps and requirements for construction within flood hazard areas can be obtained from the City of Sierra Vista".

(6) Tract boundary of the subdivision shall be clearly delineated. Location, dimension, bearings, radii, arcs, and central angles of all sites to be dedicated to the public and the use specified.

(7) Location of all adjoining subdivisions with date, book, and page number of recordation noted or, if unrecorded, so marked.

(8) For subdivisions as defined under A.R.S. § 32-2101, provide a note stating: The Arizona Department of Water Resources issued a determination of adequate water supply on (date).

f. Non-Vehicular Access Easement

(1) Per the Maricopa County Roadway Design Manual, as amended by the City of Sierra Vista, direct access from a residential property to a street classified as an arterial or major collector is prohibited. A 1-foot non-vehicular access easement and 6-foot masonry wall are required for portions of a lot that abut an arterial or major collector roadway.

g. Connectivity

(1) All residential subdivisions shall incorporate pedestrian connections designed to connect the proposed subdivision with adjoining existing, or future, residential subdivisions, multi-use paths and/or existing future parks. Such connections are not required to exceed 50 feet beyond the property lines of the development.

(2) Connection points shall be as determined during the preliminary platting stage of the development and shall be clearly identified on the final plat.

(3) Where residential subdivisions are located adjacent to a multi-use path, connection to said path shall occur, on average, every 1,000 feet or as determined by the City.

(4) Pedestrian routes shall be paved and, where located in drainage outlet areas, a minimum of 4 feet in width shall be dedicated to a flat side-to-side surface separate from the drainage portion.

(5) At least one of the proposed pedestrian connections shall meet Americans with Disabilities Act (ADA) requirements for slope and surfacing. Exceptions shall be as determined by the City.

hf. Final Plat Certificates. The following certificates and acknowledgments shall appear on the final plat. Such certificates shall be lettered or printed legibly with permanent opaque ink and shall be signed and dated as prescribed hereafter.

(1) A certificate signed and acknowledged by all persons holding title by deed to the lands or if lands dedicated or held in trust, the trustee shall sign the certificate, or if land is to be dedicated or mortgaged, the mortgagee shall also sign their certificate. Said certificate to indicate that it is the owner's intention to subdivide and plat the land shown and described hereon and that the public right-of-way shown hereon is hereby dedicated to the public for public use forever and that the easements shown hereon are not dedicated to the public, but the

right to use said easements for the purposes indicated is perpetually reserved for the public and no permanent building or structure shall be constructed upon said easements.

(2) A certificate executed by a land surveyor registered to practice in the State of Arizona under whose direction the survey, subdivision, and plat of the land described on the said plat was made; stating that the plat is a correct representation of all the exterior boundaries of land surveyed and the subdivision of it; stating that he has prepared the description of the land shown on the plat and that he certifies to its correctness; stating that the bearings shown on the plat are expressed in relation to the true meridian or previously established meridian or bearing and that all existing monuments shown on the plat are actually located in the ground and their location, size, and material are correctly shown. The certificate shall include the registration number, seal, and signature of the registered land surveyor.

(3) A certificate executed by a land surveyor registered to practice in the State of Arizona that all monuments are set in accordance with the provisions of this Code. The certificate shall include the registration number, seal, date, and signature of the registered land surveyor.

(4) A certificate to be signed by the City Clerk that the Council approved the final plat and showing the date of approval.

(5) A certificate to be executed by the Cochise County Recorder showing the date, time of day, fee number, book, and page number of recordation.

ig. Water Adequacy

(1) Pursuant to A.R.S. § 9-463.01.J and Cochise County Resolution 08-20 the Mayor and City Council shall not approve a final plat for a subdivision, as defined under A.R.S. § 32-2101 unless one of the following applies:

i. The Director of Water Resources has determined that there is an adequate water supply for the subdivision and the subdivider has included the report with the plat.

ii. The subdivider has obtained a written commitment of water service for the subdivision from a city, town or private water company designated as having an adequate water supply by the Director of Water Resources.

2. Review and Approval

a. The Department of Community Development shall receive, review, and process the final plat and improvement plans in order to determine its submittal compliance with the provisions of this Code.

b. The Department of Community Development shall distribute the final plat and improvement plans to the Public Works Department and Fire Department for review and comment.

c. The final plat and improvement plans shall be reviewed to ensure compliance with all pertinent code and legal requirements, including, but not limited to, codes regulating streets, sidewalks, zoning, floodplain, drainage, grading, fire, water, and utility company regulations.

d. If the City finds that the final plat and improvement plans require revisions, then the following procedure shall be followed:

(1) Comments will be returned to the subdivider or subdivider's agent identifying the necessary revisions for compliance;

(2) The subdivider shall resubmit the revised plat and improvement plans with response comments explaining any revisions made to the plat;

(3) The subdivider will continue to resubmit the plat, improvement plans, and response comments until all review comments have been satisfactorily addressed.

(4) Public Works shall stamp the improvement plans approved following compliance of all local, state, and federal provisions.

e. After all comments have been satisfactorily addressed, the subdivider shall submit the final plat on clear polyester film (mylar) with all certificates in Section 151.19.004(C)(1)(f) duly executed.

3. Committee Action. The Committee shall review the final plat for conformance with the approved preliminary plat. The Committee shall make their recommendation of conformance to City Council. The Director of Community Development or designee shall coordinate and summarize the Committee's recommendation for presentation to Council.

4. Council Action and Recordation

a. Upon approval of the public works improvement plans and receipt of the improvement security provided in accordance with the provisions of Section 151.19.005, the Director of Community Development shall notify the City Clerk to include the final plat on the next regular Council agenda whereupon the Council shall approve or reject the plat.

b. If the Council approves the plat, the City Clerk shall execute the appropriate certificate of approval upon the plat, first making sure that the other certificates required in Section 151.19.004(C)(1)(f) of this Code have been duly executed.

c. After approval of the final plat by the Council, the Department of Community Development shall record the plat in the Office of the Cochise County Recorder and pay the recordation fee. One copy of the recorded plat shall be retained by the Department of Community Development.

d. Amendment. If the Council finds that the plat requires revisions, the application shall be tabled until the revisions can be satisfactorily accomplished and the application rescheduled for Council action.

e. Denial. If the Council denies the plat, the minutes shall state the reasons for the denial. The final plat application may be re-filed at any time if revisions can resolve the reasons for the denial as originally proposed. The new filing of a final plat application for the same plat, or any portion thereof, shall be treated as a new project and will follow the procedures and requirements specified in this Section.

('76 Code, Art. 12-1) (Ord. 743, passed 4-10-86; Am. Ord. 834, passed 3-9-89; Am. Ord. 875, passed 1-10-91; Am. Ord. 947, passed 3-10-94; Am. Ord. 1043, passed 9-11-97; Am. Ord. 2003-005, passed 2-13-03; Am. Ord. 2003-008, passed 4-24-03; Am. Ord. 2008-018, passed 11-13-08; Am. Ord. 2018-002, passed 2-8-18; Am. Res. 2020-010, passed 2-13-20; Am. Ord. 2020-003, passed 4-9-20)

Section 151.19.005 Improvement Security

A. Acceptable Forms of Security. Before a subdivision plat is presented to the Council for approval, the subdivider shall post assurances, in a form acceptable to the City, to assure the installation of required public improvements. All required improvements shall be designed and constructed in accordance with the latest revision of the Uniform Standard Specifications for Public Works Construction and the Uniform Standard Details for Public Works Construction as compiled by the Maricopa Association of Governments (MAG), and the City of Sierra Vista Public Works Engineering Design Standards and Drawings, as modified and adopted by the Council. Other standards pertaining to any required improvements shall be approved by the City. The purpose of the assurances shall be to guarantee that the improvements are installed in a timely manner and paid for without cost to the City. The City Council accepts the improvement security when the associated final plat is approved.

1. Financial forms of assurance, including cash, letter of credit, performance bond, certificate of deposit, or other similar instruments, shall be filed in the office of the City Clerk in an amount equal to the sum of the cost of construction for all required improvements, including surveying, construction management, testing, and inspections, as determined by the City Engineer. All financial form of assurances for the installation of required improvements on private property shall grant to the town adequate property rights as determined by the City Attorney to allow the City or the City's contractor to complete the installation. Where, in the opinion of the Council, the subdivider has failed or neglected to install the required improvements or make required corrections within a timely manner, or to pay all liens in connection with the required improvements, the Council may use the proceeds from the assurances to install or cause to be installed the required improvements.

2. Third party trust forms of assurance prohibiting the transfer of any individual subdivision lot or block for which required subdivision improvements have not yet been installed, are permitted in lieu of financial forms of assurance.

B. Completion of Public Improvements

1. The required public improvements shall be completed and accepted within two years of final plat approval. If the plat is phased, only the public improvements for each individual phase that was approved are required to be completed within two years.

Exceptions to the two year completion date are as follows:

a. The council grants an extension for good cause. The review of the extension request shall include an evaluation of any change in conditions within or adjoining the final plat and the effect of new or current regulations on the project. Requests for a time extension shall be submitted a minimum of thirty days prior to the expiration date in writing to the Director of Community Development; or

b. An injunction or a court order requiring that the subdivision plat process cease. The platting process can commence, once the court order has been lifted, at the point in the review process where the plat had originally ceased.

c. The developer may elect to construct the sidewalks in conjunction with each individual platted lot. In this instance the subdivider is required to complete the entire sidewalk either when all the homes in the subdivision or phase of the subdivision have been constructed or within 5 years from issuance of the first building permit of each subdivision phase, whichever is earlier. Except that, portions of sidewalk not providing vehicular access to the lot, required sidewalk

ramps and required accessible routes shall be completed within the two year improvement period.

(1) In this instance, a separate financial security will be required. The financial form of assurance, shall be as stated in Section 151.19.005(A)(1) and be in an amount equal to the sum of the cost of construction. The security shall be filed in the office of the City Clerk.

2. The subdivider may submit a written request to extend the completion of the public improvements. The request shall include the reasons why the improvements cannot be completed within the stated completion period, and provide a revised deadline for completion.

a. The request for extension shall be considered by the council, whose decision shall be final.

3. A Subdivider's Agreement shall be submitted concurrently with the improvement security. The Agreement is a contract between the City and the subdivider which defines the obligations of the subdivider as they relate to the improvement security, the time frame for completing the public improvements, and the parameters for the City's acceptance of the improvements. The City Council accepts the Subdivider's Agreement when the associated final plat and improvement security are approved and accepted.

C. Release of Assurances

1. Inspections and Acceptance of Improvements. Once all items in this section are submitted and, ~~upon due notice from~~ the developer has completed ~~of presumptive completion of~~ all public improvements as called for on the approved plans and required under ~~the provisions of~~ this Code and the Maricopa County Roadway Design Manual, as amended by the City of Sierra Vista, the City will make a final inspection. If all construction is completed to the City's satisfaction, ~~this inspection shall constitute the final inspection and~~ the Director of Community Development will recommend to Council, by Resolution, the final acceptance of the public improvements for maintenance.

a. Final As-Built Plans. The developer shall provide the City with an electronic copy of as-built improvement plans for inclusion in the City Base Map. The file(s) shall be compatible with the release of AutoCAD currently being used by the City or any additional electronically approved format. The as-built plans shall show all streets, drainage, sewer, and water improvements constructed within public rights-of-way or public easements. Final as-built plans shall show the approved design conditions and reflect any field changes approved by the City Engineer and the developer's engineer. The developer's engineer shall certify that the final plans represent as nearly as possible the actual field conditions of all improvements as constructed.

b. Developer's Guarantee and Waiver of Liens. The developer shall certify on the Developer's Guarantee and Waiver of Liens form that is provided by the City that all bills for labor and materials used in the work have been paid and agree to indemnify and save harmless the City against any and all liens, claims of liens, suits, actions, damages, charges, and expenses whatsoever, which the City may suffer arising out of the failure of the developer to pay for all labor performed and materials furnished in the construction of the required improvements. Also, the developer shall guarantee all public improvements work against defective workmanship or materials for a period of two years from the date of its final acceptance by the Council.

c. Assurance Security. A security shall be provided to the City to substantiate the validity of the Developer's Guarantee. The amount of the security shall be \$200 per lot. The security shall be retained until the two-year warranty period has elapsed. The security shall consist of cash, a performance bond, a certificate of deposit or other assurance as approved by the City, which meets the requirements in Section 151.19.005(A)(1), Acceptable Forms of Security.

2. Partial Release of Assurances

a. Partial Release of Residential Subdivision Assurances for Third Party Trusts.

(1) Where a third party trust is provided as assurance for completion of improvements, a partial release of a portion of the subdivision or approved phase of a subdivision may occur, prior to the completion of all improvements, provided the partial release is proportional to the level of completion of improvements.

(2) Up to 75 percent of the lots held in a third party trust in any particular phase may be released prior to completion and acceptance of the public improvements. Any lot(s) released shall be served by the completed and inspected public improvements. Partial releases greater than 75 percent or a final release may be granted only when all of the assurable subdivision improvements have been completed, inspected, and accepted by the City.

b. Commercial Subdivisions for Third Party Trust Release. Up to 60 percent of the lots in any particular phase may be released prior to the completion and acceptance of the public improvements. Any lot(s) released shall be served by the completed and inspected public improvements. Partial releases greater than 60 percent or a final release may be granted only when all of the assurable subdivision improvements have been completed, inspected, and accepted by the City.

c. Reduction or Partial Release of Monetary Assurances. Where a bond, letter of credit, certificate of deposit, or other monetary assurance is provided, the amount of the assurance may be reduced upon partial completion of construction, but, only in a ratio that the improvement(s) bears to the total improvements indicated on the plat. Where a subdivider completes the required improvements for a portion of the final plat, monetary assurances for such improvements may be reduced only where the improvements can be used and maintained independently of remaining improvements required for the entire plat. In no case, may more than 75 percent, or 65 percent for commercial projects, of the total monetary of assurances be released prior to completion and acceptance of all improvements.

3. Substitution of Assurances. Where a third party trust is provided as assurance for completion of improvements, a substitute assurance may be submitted for review. The substitute trust includes those portions of the subdivision to be covered. Additional substitute assurances may be needed to be in place so that all of the assurable infrastructure that needs completion is covered. The Third Party Trust or other type of assurances may be entirely substituted by another form of assurance using cost estimate procedures based on the remaining improvements.

4. Additional Assurances. Notwithstanding assurances provided, if the Community Development Director, determines that grounds exist that could result in commercial insecurity that the required improvements will be completed, additional assurances may be required of the subdivider. The neglect or refusal of the subdivider to provide such additional assurances within 30 days, shall result in the immediate suspension of the issuance of any further permits unless and until further assurance is provided.

('76 Code, Art. 12-1) (Ord. 743, passed 4-10-86; Am. Ord. 875, passed 1-10-91; Am. Ord. 1043, passed 9-11-97; Am. Ord. 2005-004, passed 1-24-05; Am. Res. 2020-010, passed 2-13-20; Am. Ord. 2020-003, passed 4-9-20)

Section 151.19.006 Minor Subdivisions

A minor subdivision may be accomplished with less documentation and it provides a more streamlined process than required for subdivisions.

A. Applicability. A subdivision meeting the following criteria shall be considered a minor subdivision:

1. The number of proposed lots is ten or less;
2. All streets forming the boundary of the subdivision are fully improved, except for sidewalks that may be improved as part of the project;
3. All utility services are available at the subdivision site boundary;
4. The property is not located within a 100-year regulatory floodplain area or erosion hazard setback;

B. Review, Approval, and Recordation

1. Pre-Application Meeting. A pre-application meeting is required prior to the formal submittal of the minor subdivision application. The pre-application meeting provides an opportunity for the City and the applicant to review and exchange information regarding a proposed minor subdivision prior to the preparation and formal submittal of a subdivision plat application.

2. Application.

a. The applicant shall submit a minor subdivision application and supplemental documents as stated in the minor subdivision application.

b. Applications shall be filed and processed in accordance with the review, approval, and recordation procedures set forth in Section 151.19.004(C) Final Plat Stage.

3. Improvement Security.

a. All required public improvements shall be designed and constructed in accordance with the latest revision of the Uniform Standard Specifications for Public Works Construction and the Uniform Standard Details for Public Works Construction as compiled by the Maricopa Association of Governments (MAG), and the City of Sierra Vista Public Works Engineering Design Standards and Drawings, as modified and adopted by the Council. Other standards pertaining to any required improvements shall be approved by the City.

b. All required public improvements shall be completed and accepted prior to the issuance of certificates of occupancy. However, should the improvements not be completed and accepted prior to the issuance of certificates of occupancy, then the improvement security requirements and procedures as stated in Section 151.19.005, Improvement Security shall be followed.

(Res. 2020-010, passed 2-13-20; Am. Ord. 2020-003, passed 4-9-20)

Section 151.19.007 Minor Plat Amendments

A. Any recorded subdivision plat may be amended to:

1. Correct an error in any course or distance or other necessary item that was omitted.
2. Correct a drafting, graphic, technical, or similar type error.
3. Adjust a drainage or maintenance easement.
4. Combine, reconfigure, or adjust lots so long as:
 - a. The external subdivision boundaries remain the same.
 - b. The number of lots does not increase.
 - c. The utility easements, street access, and other public dedications are not changed or abandoned.
 - d. The number of lots does not exceed fifty (50) percent of the total lots identified on the plat.

B. Guidelines for Minor Plat Amendments

1. Lots being combined must:
 - a. be contiguous
 - b. have the same owner(s)
 - c. have the same zoning
2. The amended plat and the survey upon which it is based shall comply with the current Arizona Boundary Survey Minimum Standards.
3. Any changes to a subdivision other than those listed above must follow the subdivision or minor subdivision process.

C. Procedure. The Community Development Director is hereby authorized to approve and record Minor Plat Amendments as follows:

1. The applicant shall submit an amended plat map signed by a licensed surveyor.
2. The amended plat shall contain a revised legal description for the combined or adjusted lot(s).
3. The applicant shall pay the application fee.
4. The amended plat shall be titled "Amended Plat of " and shall contain a certification block for the signature of the Community Development Director. If more than one (1) amended plat is necessary, the successive plats shall be titled "Second Amended Plat of ", and follow in numerical order.
5. The amended plat shall be signed by the Community Development Director for certification that the only changes on the amended plat are changes as authorized above.

6. After obtaining the signature of the Community Development Director, the amended plat shall be recorded in the Office of the County Recorder, without further action by the Planning & Zoning Commission or City Council.

7. The Minor Plat Amendment process does not need to meet the Final Plat Certificate and signature requirements as stated in 151.19.005(C)(1)(f) and is not subject to the conditions of A.R.S. § 9-463.01.G.

(Res. 2020-010, passed 2-13-20; Am. Ord. 2020-003, passed 4-9-20)

Section 151.19.008 Minor Lot Divisions

According to A.R.S. §9-463.01.T, cities may regulate land splits within its jurisdictional boundaries. The state law gives the City authority to determine the division lines, area, and shapes of the parcels. Neither a preliminary plat or a final plat is required but the resulting tracts, parcels, or lots, shall conform to applicable zoning requirements and other government codes and ordinances.

A. Applicability. Each of the following shall be a minor lot division subject to the requirements of this Article:

1. The division of improved or unimproved land whose area is 2.5 acres or less into 2 or three lots or parcels for the purpose of sale or lease, where no new street is involved;
2. The division of improved or unimproved land for the purpose of sale, or lease, whether immediate or future, into 2 parts, where the boundaries of such property have been fixed by a recorded plat;
3. Lot line adjustments, whether or not a new lot is created;
4. Lot Ties, where two existing lots are joined by the removal of a lot line.

B. Review, Approval, and Recordation

1. Pre-Submittal Meeting. A pre-application meeting is required prior to the formal submittal of the minor lot division application. The pre-application meeting provides an opportunity for the City and the applicant to review and exchange information regarding a proposed minor lot split prior to the preparation and formal submittal of a subdivision plat application.

2. Application

a. The applicant shall submit a minor lot division application and supplemental documents as stated on the minor lot division application.

b. The Director of Community Development and City Engineer shall review and approve the request for minor lot division;

c. Minor lot divisions shall be reviewed for compliance with the following provisions:

(1) Does not constitute a subdivision as defined in A.R.S. § 9-463.02.A which would require compliance with subdivision platting requirements as stated in Section 151.19.004 of this Code.

(2) Results in tracts or parcels which conform to the minimum lot size requirements of the property's zoning district;

(3) Provides access to the proposed tracts, parcels, or lots in accordance with Section 151.08.005 of this Code;

(4) Results in all existing buildings complying with the setback requirements of the property's zoning district;

(5) Results in tracts, parcels, or lots, of at least the minimum size required to build in accordance with the applicable zoning district.

d. After approval, all documents shall be recorded with the Cochise County Recorder's Office.

(Res. 2020-010, passed 2-13-20; Am. Ord. 2020-003, passed 4-9-20)

Section 151.19.009 Modifications

A. Where, in the opinion of City Council, there exists extraordinary conditions of topography, land ownership, or adjacent development, or other circumstances not provided for in these regulations, the City Council may modify the provisions of this Article in such a manner and to such an extent as it may deem appropriate to the public interest. The burden of proof for City Council determination of modification rests with the subdivider. The written request for modification shall be made to the Director of Community Development and shall be submitted to the City Council after review and recommendation by the Planning and Zoning Commission.

B. In modifying the standards or requirements of these provisions, as outlined above, the City Council may make such additional requirements as appear necessary in its judgment to secure substantially the objectives of the standards or requirements so modified.

(Res. 2020-010, passed 2-13-20; Am. Ord. 2020-003, passed 4-9-20)

Section 151.19.010 Fees

Subdivision fees shall be determined according to a schedule established by resolution of the Council and posted in the Office of the City Clerk.

(Ord. 743, passed 4-10-86; Am. Ord. 1043, passed 9-11-97; Am. Ord. 2003-008, passed 4-24-003; Am. Res. 2020-010, passed 2-13-20; Am. Ord. 2020-003, passed 4-9-20)